



Learning resource

Demonstrate and apply
knowledge of cable coding,
colours, characteristics,
applications, and capacity

Level 4 | Credits 2



Te Pūkenga

Contents

Cables	3
Materials Used In Cables	4
Cable and Flexible Cord Insulating Materials	5
Determining Cable Conductor Size	12
Features of Common Cables	13
Tough-Plastic Sheathed (TPS) Cable	13
Neutral-Screened Cable	15
Mineral-Insulated Metal-Sheathed (MIMS) Cable.....	16
Moisture Penetration.....	16
Termination of a MIMS Cable	17
Cross-Linked Polyethylene (XLPE or xylene) HV cable	17
Flexible Cables and Cords.....	19
Types of Flexible Cord	20
Conductor Colours.....	21
Exceptions	22
Single-Phase Flexible Cords.....	23
Multi-Phase Flexible Cords	23
Manufacturer's Data	24
Factors affecting the selection of cables	25
Basic Cable Requirements	25
Cable Current Rating	25
Using AS/NZS 3008 for Cable Calculations	27
Voltage Drop.....	28
Determining minimum cable size based on voltage drop	29
Cable Selection Worked Example.....	32
Worked example for selecting cables sizes.....	34
Class of excess-current protection.....	36
Surge protection	36
Ambient temperature	36
Installation methods.....	38

Derating factor.....	39
Cables in contact with thermal insulation.....	39
Summary.....	40
Protecting cables against damage.....	41
Protecting cables against mechanical damage.....	41
Selecting flexible cords.....	42
Voltage drop.....	45
Induction motors.....	46
Calculating voltage drop.....	46
Summary.....	48
Maximum Demand.....	48
Harmonic Currents and Cable Current Carrying Capacity.....	49
Short Circuit Performance.....	50
Example.....	51
Example.....	51
Earth Fault Loop and cable size.....	52
Total earth fault loop impedance.....	54
Maximum earth fault loop impedance.....	55
Maximum Demand.....	56

Cables

Ask any electrician about the required cross-sectional areas of cables for standard circuits, and the answer you receive will probably be along the lines of: “1mm² or 1.5 mm² for lighting circuits, and 2.5 mm² for socket-outlet circuits”.

These are the commonly used rule of thumb sizes. However, those who undertake electrical installation work, need to understand the procedure for selecting the correct cable for a particular use.

Selecting correct cables for electrical installations is one of the most important aspects of your work as an electrician. Cables, when correctly selected and installed, ensure a safe, durable and efficient electrical system.

The information you need to correctly select cables, is contained in:

- AS/NZS 3000:2007, Incorporating Amendment No.1 and No 2,
- AS/NZS 3008.1.2:2010, and
- Manufacturers' catalogues and guides.

Please obtain AS/NZS 3000 and 3008 before working through this module.

AS/NZS 3000 defines a cable as a single cable core, or two or more cable cores laid up together, either with or without fillings, reinforcements, or protective coverings.

The following example shows the components that most cables contain. Some cables have extra sheathing, and some are not armoured. Some are flat with conductors placed side-by-side, but generally, cables differ in the *materials* that each component is made from.

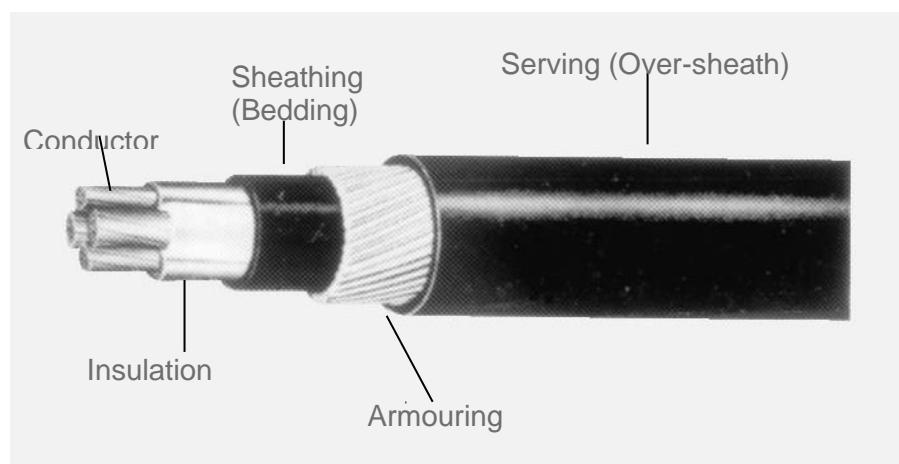

Materials Used in Cables

Modern development of plastics for insulation and sheathing, has enabled the production of cables that are tough, flexible, moisture-resistant, corrosion-resistant, and able to be used across a wide temperature range. Nearly all cables are made of plastics. The exceptions are special-purpose cables, which are made of materials such as rubber, oil-impregnated paper, and mineral insulating materials.

Conductor materials

Four conductors commonly used in cables are:

- stranded copper
- solid copper (drawn)
- stranded aluminium
- solid aluminium.

Copper

Most conductors are stranded copper. Solid conductors are a little cheaper than stranded ones but are less flexible. Copper has very good conductivity and is easily joined either by soldering or by crimping. It is however more expensive than aluminium.

Aluminium

This conductor is lighter than copper, its density being about one-third that of copper. Aluminium has a lower conductivity (about 60% of that of copper), so you need a larger cross-sectional area of aluminium for the same current-carrying capacity, otherwise excessive heating will occur. Again, solid conductors are cheaper to produce and easier to join than stranded ones but are less flexible.

Example

Consider two cables having the same conductor sizes and supplying similar *fixed loads*. One cable has copper conductors and the other has aluminium conductors. When you touch the cable sheaths, you notice that one cable is quite cool while the other is relatively warm. Which cable is the warm one, and why is this?

Solution

Remember that aluminium has a lower conductivity than copper. This means, of course, that its resistance is greater.

In fact, with a conductivity 60% of that of copper, the resistance of the aluminium conductor is 1.67 times greater than that of the copper. Conductance is the reciprocal of Resistance and is normally measured in Siemens or Mhos; and Resistance is the reciprocal of Conductance and is normally measured in Ohms or Mhos.

The greater the resistance of the aluminium conductor causes more heat energy (I^2R loss) to be created along the cable, and so it will be quite warm, compared to the cable which has copper conductors ($E = P \times t$).

In later sections of this unit, you will find that the heat given off by loaded cables is an important factor to consider when you are choosing the correct cables for an installation.

Cable and Flexible Cord Insulating Materials

Insulation needs to be a material that has high electrical resistance. Various materials provide a range of features in terms of:

The most common materials used for insulation in cables and flexible cords are:

- plastics.
- rubber and synthetic rubber
- mineral (magnesium oxide) (non-flexible) insulation.

Plastics

Plastics are divided into two main groups:

- thermoplastics
- thermosetting plastics.

Thermoplastics

Thermoplastics become soft when warmed and harden again when cooled. The process is repeatable, because no chemical change to the thermoplastics occurs. The thermoplastics that are of interest to us are polyvinyl chloride (PVC) and polyethylene (PE).

PVC (Normal)

PVC is used to make the common tough-plastic sheathed (TPS) general wiring cables and flexible cords.

PVC is a thermoplastic material, that is, it softens when heated. However, overheating can result in irreversible decomposition of the material. Above 115°C, the decomposition produces hydrochloric acid, which attacks copper conductors. Also, cooling below 0°C can make PVC brittle, and it may shatter (cold shatter). The operating temperature range of standard PVC cables and cords is from 0°C to 60°C.

However, the composition of PVC can be modified to allow temperatures of up to 85°C. This modified material is called high- temperature PVC.

UV-PVC is another form of PVC. It is treated to provide additional resistance to deterioration from high levels of ultra-violet light (sunlight).

Thermosetting plastics

Thermosetting plastics undergo a chemical change when they are subjected to heat and pressure and cannot be re-plasticised by further heat and pressure.

The most common thermosetting material used as cable and cord insulation is cross-linked polyethylene, which is abbreviated to XLPE and often called xylene. XLPE retains its strength at 90°C, a higher temperature than most thermosetting plastics, and has superior insulating properties. It is therefore particularly useful in high-voltage cables.

Rubber insulation

Various rubber compounds are used for cable and cord insulation. The temperature limit required for the insulation determines what rubber compound is used. To describe rubber insulated cables and cords, we usually state the temperature limit.

Examples of common types are:

- 60°C rubber (vulcanised rubber, for flexible cables only)
- 85°C rubber (butyl rubber)
- 150°C rubber (silicon rubber).

Synthetic rubber

Synthetic rubber is a material which has been developed to have the same properties as rubber. Ethylene propylene rubber (EPR) is one example, and has physical and electrical properties similar, but superior to, butyl rubber.

Mineral insulation

Magnesium oxide is a mineral in the form of a white powder which, when tightly compressed, makes an excellent insulating material within metal-sheathed cables. Its great advantage is its ability to withstand very high temperatures, and so the current and temperature ratings of mineral-insulated metal-sheathed (MIMS) cables are higher than those of other cables.

The main disadvantage of magnesium oxide as an insulator is that it is hygroscopic, which means it absorbs moisture.

However, this problem can easily be overcome by:

- heating about 500 mm back from each end of the cable soon after it is cut;
- testing it at 500 VDC to obtain an absolute minimum of 0.01 mega-ohms (10k Ω) insulation resistance;
- terminating with the correct glands, and seals containing sealing compound and according to manufacturer's specifications.

When this procedure is carried out correctly according to the manufacturer's instructions, the seal remains permanent for the entire service life of the cable.

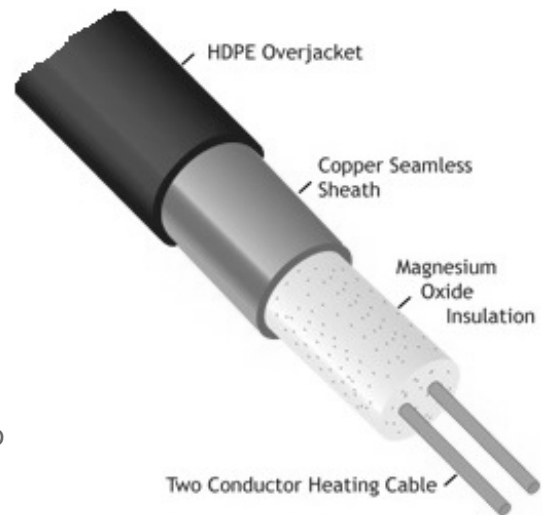

Paper Insulation

Paper is an excellent insulator and is used in HV cables to insulate conductors. The example (right), shows a typical construction.

The following table serves to indicate some of the properties of some of the more commonly used insulating materials in cables and cords.

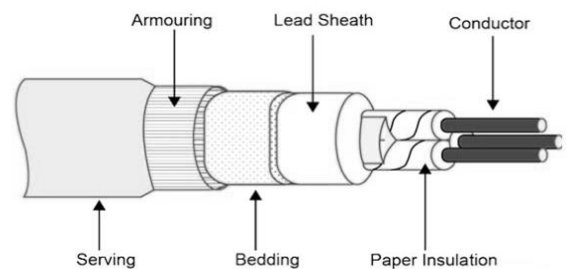

Insulation Material	Temp °C		Conditions							Electrical Properties		Applications
	Max	Min	Weather	Oil	Chemicals	Water	Self-extinguishing	Sunlight	Mechanical	Insulation Strength	Electrical Resistance	
Paper	80	-30	n/a	2	3	4	3	n/a	3	1	1	HV armoured cable
PVC Normal	60	0	3	2	2	2	2	3	2	2	2	General wiring
PVC Hi Temp	85	0	3	2	2	2	2	3	2	2	2	Hi temp applications
Rubber	60	-55	4	4	3	2	4	4	3	2	2	Flexible cable
Polychloroprene	60	-40	2	1	3	4	2	3	3	2	2	Sheathing
Butyl Rubber	85	-55	3	4	2	2	4	4	4	2	2	Hitempwiring
Silicon Rubber	150	-55	1	3	3	2	3	4	4	2	2	Hitempwiring
Asbestos Rubber	80	-55	3	4	3	4	2	3	3	2	2	Hitempwiring
Cambric and rubber	80	-55	3	4	3	4	2	3	3	2	2	LV and MV cables
Polythene	90	0	1	3	2	2	4	2	3	1	1	Sheathing
Polythene (hi density)	80	-40	1	3	2	2	4	3	1	1	1	LV and MV cables
Cross linked polyethylene (XLPE)	90	0	1	3	2	2	4	3	3	1	1	HV cables
Nylon	100	-40	1	1	1	3	3	3	1	2	2	Main entry
Magnesium Oxide	250	-40	n/a	n/a	n/a	4	1	n/a	n/a	1	1	Hi temp applications

Ratings above given as;

1 – very good; 2 – good; 3 –fair; 4 – poor; n/a is not applicable.

Physical and Electrical Data Guide to Materials' Performance

The data provided below is an indication of the performance of a wide range of materials utilised in cable construction. However, it is important to realise that the finished properties of a material depend upon the formulation. Materials may be formulated to give excellent performance in one particular respect to the expense of deterioration in other important properties.

	Electrical	Heat	Cold	Flame	Oil	Solvents	Ozone	Water	Abrasions
General Purpose Rubber (Natural rubber/ Styrene-Butadiene rubber)	5	3	8	1	2	2	1	4	5
Cross-Linked Polyethylene (XLPE)	8	7	8	1	5	9	6	9	6
Silicone Rubber	5	9	9	2	5	5	6	4	3
Ethylene-Propylene Rubber (EPR)	8	7	9	1	3	4	8	8	3
Ethylene-Vinyl Acetate (EVA)	5	8	6	2	2	4	7	4	4
Flame Retardant Ethylene Vinyl Acetate	2	8	5	7	5	5	7	2	5
Flame Retardant Ethylene Methy lacrylate (EMAorVAMAC)	2	8	6	7	6 - 7	5 - 6	7	7	6
Chlorinated Polyethylene (CPE) Ordinary Duty Low Acid (4 per cent acid emission)	3	7	6	8	7	6	7	7	7
Chlorinated Polyethylene (CPE) (15 per cent acid gas emission)	3	7	6	8	8	7	7	7	8
Polychloroprene (PCP)	2	4	5	8	7	6	7	7	7
Nitrile Butadiene-Polyvinyl Chloride (NBR/PVC)	2	4	3	5	8	5	5	5	8
Chlorosulphonated Polyethylene (CSP) Ordinary Duty Low Acid (4 per cent acid emission)	3	7	6	8	7	6	7	7	7
Chlorosulphonated Polyethylene (15 per cent acid emission)	3	7	6	8	8	7	7	7	8

Where: 0 = Bad and 10 = Excellent

Below is a performance guide for the sheathing materials commonly utilised in cable construction.

	Smoke / acid Emission	Toxic gas Emission	Flame Propagation	Flexibility	Heat	Cold	Fluids	Abrasion
Heavy Duty HOFR	1	1	9	9	7	7	7 - 8	8
Low Smoke HOFR	5	3	8 - 9	9	7	7	8	7
Flame Retardant Zero Halogen Sheath	9	8	7	8	8	5	7	6 - 7
Flame Retardant Zero Halogen HOFR Sheath	9	8	7	7	8	6	7 - 8	7 - 8

Where: 1 = Poor and 9 = Excellent

Armouring, Sheathing and Screening Materials

All cables must be protected against any risk of mechanical damage that is liable to occur under normal conditions of service.

Sheathing provides the first line of protection. It gives a range of protection (depending on the material used) in terms of smoke/acid emission, toxic gas emission, flame propagation, flexibility, and resistance to heat, cold, fluid and abrasions. For example, polychloroprene is a synthetic rubber that is produced by polymerization of chloroprene. It has good chemical stability and maintains flexibility over a wide temperature range. Can be used for sheathing of flexible cables.

Further protection may include enclosing sheathed cables in troughs, trunking, ducting or conduit. However, rather than lay cables in enclosures, it is often more convenient to use armouring to provide further mechanical protection. Steel wire is the most common method used (e.g. in Steel Wire Armoured Cable) but steel tape armour and aluminium strip may also be used.

Metallic armours and sheaths of cables must be earthed. They may be used as protective earthing conductors if requirements are met. These requirements are that;

- the armouring or sheathing is used as an earth-continuity conductor only to protect its associated conductors and apparatus.
- its conductance must be adequate for the purpose.
- joints must be sound and protected against corrosion.

Identifying Different Types of Cable

Many cables are known by their abbreviations and initials, which describe the makeup of each layer from the inside to the outside. The following are most common:

VRI	vulcanised rubber insulation
PCP	polychloroprene
HOFR	heat, oil and flame retardant
MIMS	mineral-insulated metal-sheathed
MICS	mineral-insulated copper-sheathed
MIAS	mineral-insulated aluminum-sheathed
PVC, PVC SWA PVC	PVC insulated, PVC sheathed, steel-wire armoured, PVC served
XLPE, PVC SWA PVC	cross-linked polyethylene insulated, PVC sheathed, steel-wire armoured, PVC served
PILC	paper insulated, lead covered.
EPR	ethylene propylene rubber
'PVC served' means a final outside protective coating of PVC.	

To identify any cable, state the conductor material, the number of cores, and their cross-sectional area, and then the outer layers, for example:

Copper, 1 - 4 mm² (copper conductor, one core, 4 mm² in cross section), or **Copper, 1 core 4 mm², PVC.**

Aluminium, 4 - 25 mm² (aluminium conductors, four cores, each of 25 mm² cross section), or Aluminium, 4 core 25 mm², PVC PVC SWA PVC.

Determining Cable Conductor Size

Conductor size can be determined by viewing the cable manufacturer's markings on the cable sheathing, or the cable manufacturer's labels on the cable drum reel or boxes. You can also determine the size of a cable conductor by measurement using a micrometer and checking the conductor size next to the cable manufacturer's cable data.



For example, let's say we wanted to determine the size of an unidentified length of twin and earth TPS three-stranded copper conductor cable. If, when measuring one strand of copper of a 3-strand conductor we recorded a measurement of 0.77 mm using a micrometer we could determine the cross-sectional area.

By checking this measurement against the cable manufacturer's data, you find that the three-stranded 3/0.77 mm conductor is a 1.5 mm² twin and earth TPS cable. (Refer to the table below):

Twin and earth copper TPS cable data

CONDUCTOR		CABLE			MINIMUM INSTALLED BENDING RADIUS mm	STANDARD PACKING			
Nominal area mm ²	Number and Diameter of wires No./mm	Overall diameter		Approx. Mass per 100m kg		Length m	Reel / Drum size		Approx. Gross Mass kg
		Min. mm Major x Minor	Max. mm Major x Minor				Diameter mm	Width mm	
1.0	1/1.13	8.8 x 4.1	9.2 x 4.4	7.2	25	100	325	100	8
1.5	3/0.77	10.4 x 4.7	10.9 x 5.0	10	30	100	325	100	11
2.5	7/0.67	12.2 x 5.4	12.9 x 5.8	15	35	100	325	150	16
4	7/0.85	14.7 x 6.4	15.4 x 6.7	21	40	100	325	200	23
6	7/1.04	16.4 x 6.9	17.1 x 7.3	27	45	100	400	175	29
10	7/1.35	20.6 x 8.5	21.4 x 8.9	41	55	500	740	520	270
16	7/1.70	23.3 x 9.5	24.2 x 10.0	60	60	500	740	600	370

Features of Common Cables

Common cables that we use have various features that you should know. These cables are:

- PVC insulated cables
- XLPE insulated cables
- mineral insulated cables.

Tough-Plastic Sheathed (TPS) Cable

This is the most common cable used in fixed or permanent wiring of installations. It consists of one to four individual PVC insulated conductors, and a tough PVC plastic sheath covering. Each inner PVC conductor insulation layer is coloured to provide identification. TPS cable has a voltage rating of 600/1000 V.

TPS cable is the cheapest form of electrical wiring. It is used almost entirely for wiring houses and commercial installations, particularly those of timber construction, where circuits are run through joists in walls, under floors, in ceilings, or on the surface.

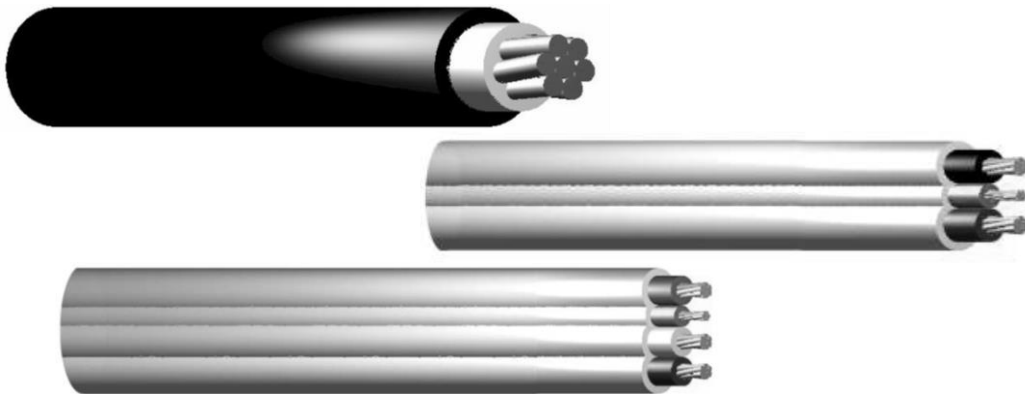

TPS can be split into two categories:

- 1) Flat TPS trades some of the toughness for an Easi-peel sheath and is commonly used for the fixed wiring of domestic and industrial lighting, power outlets, and heating.
- 2) Circular TPS retains the tough plastic sheath and is more commonly used for commercial and industrial wiring to motors, heating, and lighting, and areas where glands are required.

For lighting and general-purpose outlet sockets, the usual system is the loop-in method. The figure on the next page shows TPS cables used in this way for a lighting circuit.

An advantage of TPS cables is that they are easy to install. In places where they are accessible, they must be supported. AS/NZS 3000 Section 3 specifies the distance needed between supports in an electrical installation. Where the cables are inaccessible, as in flat or lean-to roofs, under floors, or in spaces formed by a lowered ceiling such as a false or suspended ceiling, they need not be clipped, provided the surface where they rest is dry and reasonably smooth.

Where cables are installed vertically or just off the vertical in inaccessible positions, special precautions must be taken to ensure that they are adequately supported at the top of the run, if the drop is more than five meters.

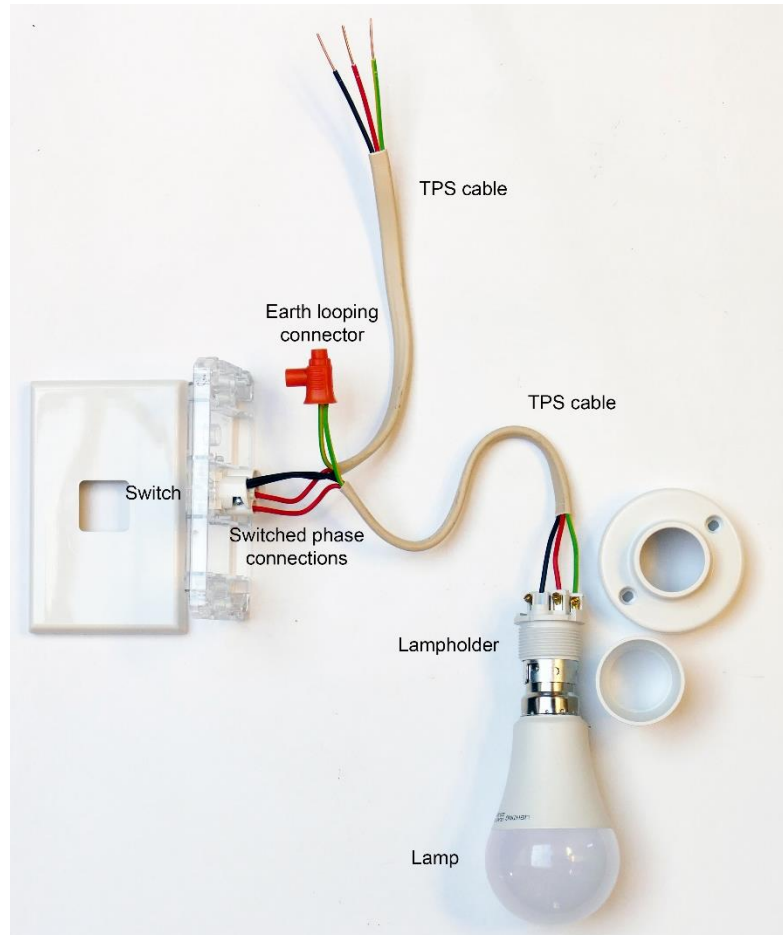

The following figure shows a typical application of TPS cables for an installation.

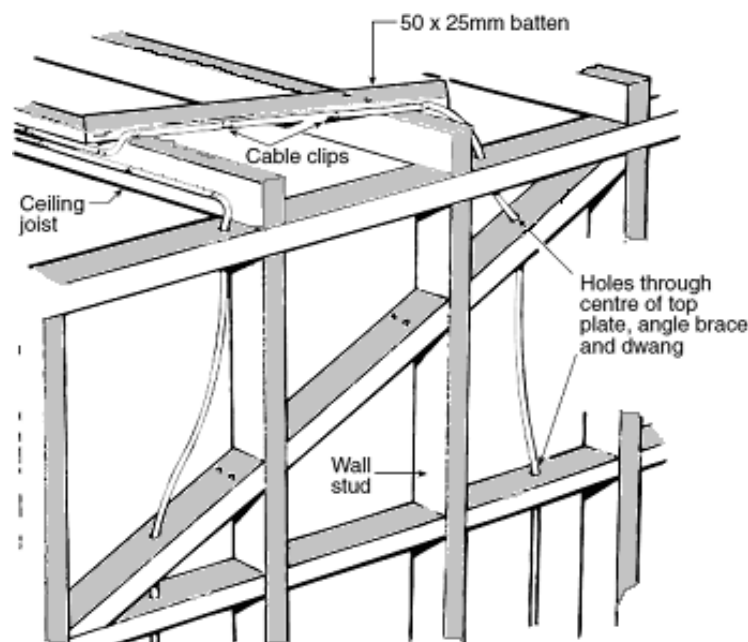

Tough-plastic sheathed cables should be installed only where they are protected against physical damage or are out of reach. Examples of suitable areas are partitions and false ceilings.

Because of the thermal limitations of the plastic insulation, you should not install TPS cables in areas with high ambient temperatures. TPS cables should also not be installed in very cold areas (freezers and chillers), because the plastic insulation will become very brittle and break away. This is called cold shatter. EPR cable should be used instead.

Neutral-Screened Cable

Neutral-screened cable is rated at 600/1000 V and consists of one or more insulated cores surrounded by an outer stranded conductor screen. This provides protection as well as an outer conductor. The whole of the cable is covered with a tough plastic sheath.

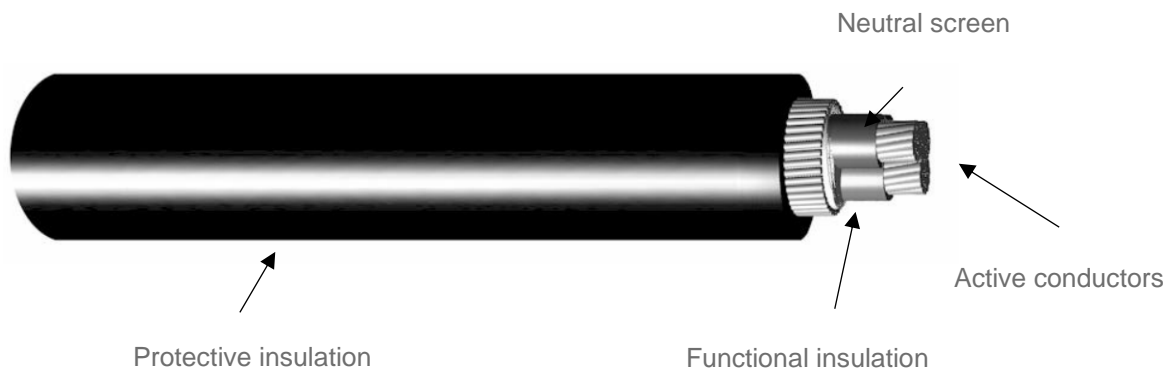

Neutral-screened cables are commonly used for underground or overhead service mains or sub-mains. The diagram below shows the special type of clamp used for supporting aerial neutral-screened cables. The outer sheath of the cable is clamped firmly, so it cannot be damaged. The clamp is normally made of a galvanised metal.

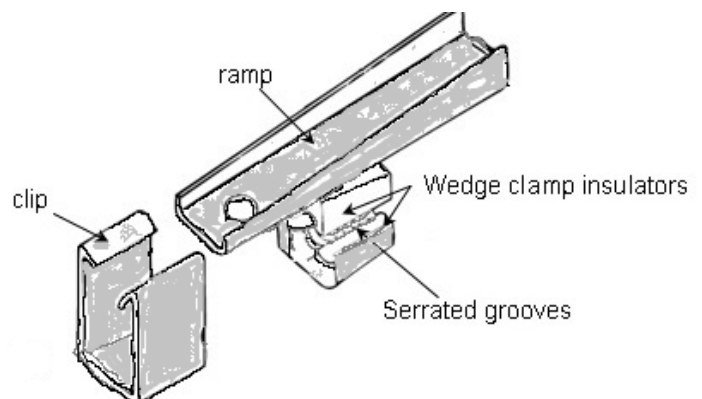

The sag of aerial neutral-screened cables is considerable because of its weight. Because of this the positioning of supports is important. Intermediate supports may be necessary when long spans are required. The outer screen conductors may be used only for a neutral or an earth conductor.

The big advantage of neutral-screened cable is protection against electric shock. If the cable is damaged or cut with a sharp tool such as a spade, contact with the live conductor is not possible without first contacting the neutral screen which is at, or near earth potential. When both live conductor and neutral are contacted, two things happen. The circuit protection operates, and the cutting tool is held at earth potential and is thus safe.

Mineral-Insulated Metal-Sheathed (MIMS) Cable

This cable, rated at 0.6/0.6 kV or 1/1 kV, consists of solid copper or aluminium conductors embedded in highly compressed magnesium oxide powder. It is sheathed with a seamless solid-drawn metal sheath. Various metals can be used for the sheath, but copper is the most common.

As MIMS cables are fireproof, corrosion-resistant in normal atmospheres and mechanically strong, they can be installed under almost any conditions. Their flameproof qualities make them ideal for wiring furnaces and for installations where gas or explosive mixtures are present. MIMS cables, however, should not be used in installations where the sheathing is likely to be subject to chemical or electrolytic (galvanic) attack. In these circumstances, you should use PVC covered cable.

Mineral-insulated cables are manufactured using single, two, three, four, and seven cores. Sizes range from 1.0 mm² up to 400 mm².



Moisture Penetration

Magnesium oxide insulation is hygroscopic, that is, it absorbs moisture when exposed to air. Moisture makes the insulation resistance fall rapidly. However, as the absorbed moisture travels along the cable, its rate of progress slows as it moves further away from the ends.

Consequently, after a long time (even after a few months), only about 450 mm from the ends of the cable will be affected.

For this reason, although the cable gives a very low insulation resistance reading if it is tested with the ends unsealed, it is relatively straightforward to restore the high insulation resistance by stripping back the sheath a short distance, which will usually remove all the damp insulation. If not, the moisture in the remaining insulation may be dried out by applying a flame a short distance from the end of the cable and slowly moving it towards the unsealed end.

Termination of a MIMS Cable

A MIMS cable is terminated by a seal, which excludes moisture and a gland, which anchors the cable at a box, and provides earth continuity. This can be seen in the sketch below, which shows the components used to terminate a MIMS cable.

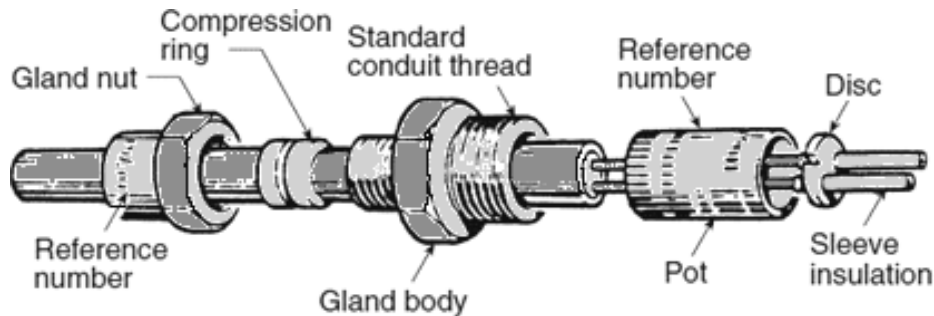

The seal consists of a brass pot filled with sealing compound, and a fibre or neoprene disc that closes the mouth of the pot. V105 PVC, silicon rubber, or heat-shrink sleeves are used to insulate the conductor tails.

Cross-Linked Polyethylene (XLPE or xylene) HV cable

Xylene is a thermosetting material formed by adding a peroxide reagent to the polyethylene, prior to the extrusion process. The resulting insulation has very high resistance values and can operate at higher temperatures than normal PVC.

Xylene insulated cables are rated at 90°C for continuous operation, at 130°C for short periods, and up to 250°C for short-circuit conditions. Thus, these cables have higher current ratings than comparable PVC insulated cables.

However, care must be taken in wiring design to ensure that the consequent higher voltage drop does not exceed the limitations stated in AS/NZS 3000:2007. (The calculations for voltage drop in cables are covered in the next section of this unit).

Xylene cables are widely used in general wiring for high voltage main and sub-main cables at 600/1000 V rating. Because of its excellent insulation properties, xylene insulation is also used to insulate high voltage (110kV) underground cables.

The table on the following page summarises cable features.

Cable	Temp. °C		Moisture	Corrosive Conditions, Weather, Oil, Chemicals	Mechanical Strength	Uses		Notes, Precautions
	Max.	Min.						
Vulcanised rubber	60	-55	G	F	F	Low temp. applications	Flexible cords Coolstores Trailing cables in lifts, quarries and mines	Flexible armour or a screen of tinned copper wire braid may be incorporated for additional protection. Vulcanised rubber unsuitable where ozone from electric sparking is present.
Butyl rubber	85	-55	G	G	F	Wiring ships		
Silicon rubber	150	-55	G	F	G	High temp. machine windings		
Thermoplastic (synthetic rubber)	90	-45	VG	G	G	Welding cables Refrigeration plants		Excellent ozone resistance Not recommended in excessively hot oily environments
Paper insulated lead or aluminium sheathed	80	-30	F	F	G	High voltage mains cables Extra high voltage distribution cables		Specialist terminating techniques required Armoured and served where exposed to mechanical damage
PVC Light duty Circular and flat PVC insulated and sheathed	70	0	VG	G	G	General wiring TPS cables Neutral screened cables		Additional protection required where exposed to mechanical stresses or installed underground.
PVC High temperature	85	0	VG	G	G	General wiring, Including hot situations such as heating and cooking appliances		
Cross-linked polyethylene (XPLE)	90	0	VG	VG	G	General industrial and commercial wiring Rising mains cables High voltage cables		
Mineral insulated Meatal sheathed (MIMS)	250	-40	VG	VG	VG	General wiring, and in high temperature situations, or where risk of fire or explosions Special cables for floor warming		Not flexible. Loops or bends required at machines Aluminium sheathing liable to corrode Overall PVC sheath required in corrosive situation or where installed underground or in concrete ducts.
Key: F Fair G Good VG Very Good								

Flexible Cables and Cords

Heavy mobile electrical equipment, such as welders, cranes and mechanical machinery, are connected to a permanent wiring system by flexible cables.

Portable electrical appliances as well as light pendants and portable light fittings, are connected to a permanent wiring system by flexible cords.

The only difference between a flexible cable and a flexible cord, is the size of the conductor or conductors.

Flexible cable consists of one or more conductors, each formed of a group of wires. The diameter of the wires is greater than 4 mm², but not so large as to inhibit flexibility.

Flexible cord is like flexible cable, but the cross-sectional area of each conductor does not exceed 4 mm².

The flexibility of these cables and cords is largely a result of the conductors being made from groups of small-diameter strands of copper wire. The diameter of the strands varies from 0.21 mm to 0.31 mm, depending on the size of the cable or cord. The number of copper strands in each conductor is usually 23 or 40, again depending on the size of the cable or cord. A conductor and its insulation are called a core.

The general construction of a round three-core flexible cord is illustrated below.

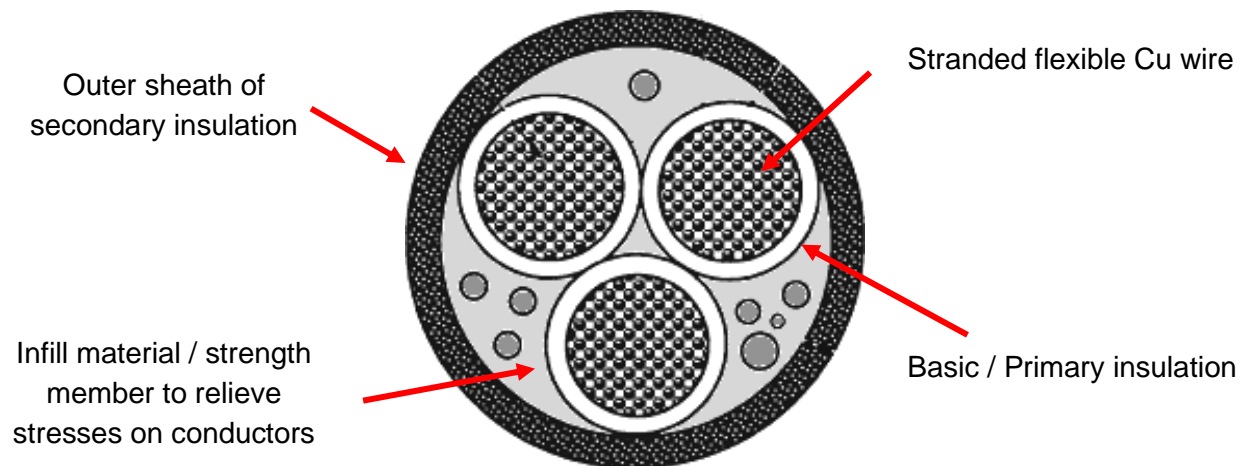





Note that the flexible cord shown has, in effect, two sets of insulation. Each conductor is insulated from the others, by a covering of non-conductive material to contain the current. This insulation material is usually colour-coded to identify live (phase or active), neutral and earth conductors. (We will cover colour-coding later in the unit.) Further protection is provided on most flexible cords in the form of an outer sheath of insulating material enclosing all the inner conductors.

The conductor's insulation is the *basic* insulation and the outer sheath is the supplementary insulation. This combination is called *double insulation* and is the basis for double-insulated appliances.

Some flexible cords such as Trurip have only one layer of insulation. These cords are for light duty use only and should not be used for extension leads or where conditions are rough. Trurip cords are mainly used for table lamps, radios and clocks (not that common anymore)

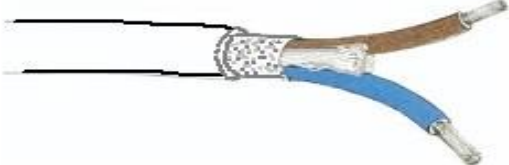
Types of Flexible Cord

Flexible cords are available in many types and sizes. The figure below shows some of the more common varieties and their uses.

	<p>Flat section 2 core, light duty "trurip" p.v.c. cord, suitable for light pendants.</p>
	<p>Round section 2 core, light duty p.v.c. and suitable for light pendants.</p>
	<p>Round section 2 core, p.v.c. cord suitable for handlamp leads and cords for double insulated appliances.</p>
	<p>Round section 3 core p.v.c. for appliance cords, and extension leads. Available in high temperature p.v.c. for temperatures up to 85°C. Also available with a silicone rubber core and sheath insulation to withstand temperatures up to 150°C.</p>
	<p>Unkinkable cord with rubber and cotton braid sheath. Useful as cords, for irons, toasters or where cord twisting can be excessive.</p>
	<p>Copper braided screen flex (C.B.S.) has an earthed copper braid between the outer sheath and the cores for protection against damage. Used on machines such as welders and drills.</p>

Conductor Colours

It is a requirement of AS/NZS 3000:2007 Section 3.8.1 that conductors will be clearly identified to indicate their intended function; i.e. active, neutral, earthing or equipotential bonding in any installation.

Where identification is achieved using the colour of the conductor insulation, the colours specified in AS/NZS 3000:2007, Table 3.4 shall be used.

Specifically, for installation wiring:

Function	Colour
Earth (E)	Green/yellow
Equipotential bonding	Green/yellow
Neutral (N)	Black or light blue
Active (A) or Phase (P)	Any colour other than green, yellow, green/yellow, black or light blue

Note:

1. *Conductors with green, yellow or green/yellow combination coloured insulation or sheathing shall not be used as active or neutral conductors in installation wiring.*
2. *When green/yellow is used, one colour shall cover not less than 30% and not more than 70% of the surface area, with the other colour covering the remainder of the surface.*
3. *Recommended colours for actives are:*
 - a). *Red or brown for single-phase; or*
 - b). *Red, white or dark blue for multiphase.*
4. *Where colours are used for the identification of cable cores, AS/NZS cable identification colours and European cable identification colours shall not be combined within the same wiring enclosure or the same multi-core cable.*

Sleeving may be used for colour identification, by sleeving using colours corresponding to those listed above and at each, and every termination for the following purposes:

- conductors with black or light blue insulation used as active conductors; or
- conductors with any colour other than green, yellow, green/yellow, black or light blue insulation used as neutral conductors; or
- conductors in multi-core cables with any colour other than green, yellow or green/yellow insulation used as earthing conductors.

This sleeving must be colour-fast, non-conductive material that is compatible with the cable and its location. Any single-core cable with a colour other than green, yellow or green/yellow insulation, used as an earthing conductor, must be identified continuously along the entire length.

Sleeving may not be used at terminations or along the entire length, to identify a green, yellow or green/yellow colour-insulated conductor as an active or neutral conductor.

Exceptions

Protective earthing and equipotential conductors do not need to be coloured green/yellow in the following situations:

- When a bare or aerial conductor used as a protective earthing conductor.
- Where a suitable screen of a multi-core cable is used as a protective earthing conductor, it shall be acceptable to identify the portion of the screen from the point of separation of the cores to the conductor termination as the earthing conductor.
- When an insulated protective earthing conductor is not normally manufactured in the green/yellow colour combination, e.g. silicon compounds.

In installations such as these, the use of sleeving at terminations is recommended wherever it is not obvious that the conductor is being used for earthing purposes.

An active or neutral conductor does not need to be coloured in accordance with the colours permitted by Table 3.4 when:

- insulated conductors in a multi-core flexible cable have each core clearly identified by means of numbering, lettering or equivalent means;
- or conductors of flexible cords and cables are identified by alternative colours in accordance with AS/NZS 3000:2007, Clause 3.8.3.3; or
- insulated aerial conductors are identified by several small longitudinal ribs around the circumference, the neutral conductor shall be identified by multiple longitudinal ribs evenly spaced around the entire circumference and length of the conductor that clearly distinguish it from the other conductors.

AS/NZS 3000:2007, Clause 3.8.3.3 specifies European cable identification colours.

The table below shows the coordination of conductor insulation colours of single-phase cables manufactured to current and superseded AS/NZS standards. This includes flexible cords and cables.

Single-Phase Flexible Cords

Superseded AS/NZS Flexible Cords	Function	European Cables and Current AS/NZS Flexible Cords, Flexible Cables and Equipment Wiring
Red	Active (Live)	Brown
Black	Neutral	Light Blue
Green	Earth	Green/Yellow (Bi-Colour)

Multi-Phase Flexible Cords

Current AS/NZS Cables	Function	European Cables
Red	Phase(P) or Line 1(L1)	Brown
White	Phase(P) or Line 2(L2)	Black
Blue	Phase(P) or Line 3(L3)	Grey
Black	Neutral(N)	Blue
Green/Yellow	Earth(E)	Green/Yellow

Note:

1. The neutral core may or may not be included in a multi-core cable or cord.
2. The European active colour for multiphase cables and cords for all phases is brown.
3. Care should be taken with imported equipment that does not use AS/NZS colour codes.
Test to make sure first.

Manufacturer's Data

Information about the construction of a cable can be found in its abbreviated name.

For example, consider the following:

6 x 16mm² copper conductors, PVC, PVC, SWA, PVC

The components of the name refer to the components of the cable in the order, generally, of:

- Insulation
- Sheathing
- Armouring
- Servicing

We can therefore see that this cable would have the following characteristics:

6 x 16mm² copper conductors, PVC, PVC, SWA, PVC

Conductor Material	Copper
Number of conductors	Six
Conductor Size	16mm ²
Insulation	PVC
Sheathing	PVC
Armouring	SWA
Servicing	PVC

6 x 16mm² copper conductors, PVC, PVC, SWA, PVC

Other codes include:

- TPS – Tough Plastic Sheathing
- MIMS – Mineral Insulation, metal sheathing

Factors affecting the selection of cables

This section looks at cables required for mains, sub-mains, sub-circuits and flexible connections. It looks at the factors that influence their rating, and the methods used in cable selection.

After studying this section, you should be able to use cable current rating tables and apply appropriate rating factors to select the correct cable for a specified current requirement.

Basic Cable Requirements

A cable must be able to carry electrical energy efficiently from the supply source to the load. The cable's conductors and insulation should not deteriorate with age, and the sheath of the cable must adequately protect the conductors and the insulation it surrounds from mechanical damage, chemical attack, high external temperatures and moisture.

The heat generated in cable conductors must be limited to within the maximum working temperature of the conductor insulation as specified by the manufacturer.

To ensure the correct voltage and current are supplied by a cable, you must consider the following factors when selecting the cable:

- The current rating of the cable I_N (And also the PSC of the circuit).
- The voltage drop along the cable (length of run).
- The class of excess-current protection used (Type A, B, C MCB).
- The ambient temperature (Environmental conditions).
- Installation methods (Earthing requirements and mechanical factors).
- Derating factor. (1Φ , 3Φ , temperature etc.).

Cable Current Rating

The current rating for cables, is the highest RMS current that can be carried under specified conditions by a cable conductor without the insulation temperature limit being exceeded. The overriding consideration is the maximum temperature limit of the insulation as the conductor would be able to withstand considerably higher temperatures.

Cable current ratings are based on data obtained from research authorities and cable manufacturers. The following tables contain some typical values that you would find in cable specifications.

Current carrying capacities of PVC insulated and PVC sheathed single phase two core and earth cables, un-armoured

Conductor	Current rating (Based on 30°C ambient air temp.)			Voltage drop
1	2	3	4	5
Conductor size mm ²	Unenclosed in air (single phase) A	Buried direct (single phase) A	Buried in duct (single phase) A	Single phase voltage drop m V/A.m
1.0	15	23	18	42
1.5	19	30	24	29
2.5	27	40	31	18
4	35	52	40	11
6	44	65	52	7
10	64	88	70	4.4
16	85	115	90	2.8

Current carrying capacities of PVC insulated and PVC sheathed three phase three core and earth cables, un-armoured

Conductor	Current rating (Based on 30°C ambient air temp.)			Voltage drop
1	2	3	4	5
Conductor size mm ²	Unenclosed in air (three phase) A	Buried direct (three phase) A	Buried in duct (three phase) A	Three phase voltage drop m V/A.m
1.0	12	20	15	36
1.5	17	26	20	28
2.5	23	34	27	15
4	32	44	35	9.3
6	40	56	44	6.5
10	54	75	60	3.8
16	72	96	76	2.4

It is important that you note the ambient temperature at which they are based. Other tables might be based on other ambient temperatures.

Using AS/NZS 3008 for Cable Calculations

The tables in AS/NZS 3008 set out the current able to be carried by a cable, the method of installation, and the environmental conditions under which the cable can be used.

They also give the current ratings of various cables used in specified conditions. If, for example, you are considering a TPS twin-and-earth cable of 2.5 mm² cross-sectional area, the current ratings are X amperes when enclosed in conduit and Y amperes when clipped direct to a surface.

The lower current rating when the cable is enclosed, is due to the heat produced by the cable conductors raising the temperature within the enclosure. The cable current rating must be reduced accordingly to prevent overheating of the cable insulation. On the other hand, when the cable is clipped to a surface, it is adequately ventilated. Heat build-up is thereby eliminated, and the cable can be up-rated accordingly to Y amperes.

The explanations of cable calculations contained in this resource should be read in conjunction with AS/NZS 3008.

Tables will be referenced in this resource but not shown.

You will need to have AS/NZS 3008 available to look at as we go through the calculations.

Please make sure you have obtained a copy of AS/NZS3008 before moving on.

Voltage Drop

When you have selected a cable with a suitable current rating for the circuit, you must consider the route length of the cable run and the resulting voltage drop across the cable length (v.d.).

Route length is discussed in AS/NZS 3000:2007: Appendix B: Table B1 and can be considered, as the distance measured along a run of wiring from the origin of a circuit to a set point (for example, the distance measured between a switchboard and a motor).

When a cable supplies electrical energy to a load, a voltage drop occurs along the length of the cable, and the degree of this voltage drop depends on the:

- conductor material (resistivity)
- cross-sectional area of the conductor
- route length of the conductor
- amount of current flowing in the conductor.

The voltage drop must be kept to a minimum so that the load can operate at its correct input supply voltage. Induction motors, for example, are very sensitive to supply voltage variations. Their torque, being proportional to the square of the voltage, is greatly reduced when only a slight reduction in supply voltage occurs.

For example, if the supply voltage to a motor is reduced by 5 % (that is, it is reduced to

0.95 of its rated value), the torque produced by the motor will be reduced to $(0.95)^2$, which is 0.9, or 90 per cent of its rated value. So, a 5 % drop in voltage will cause a 10 % drop in torque.

$$T \approx V^2$$

AS/NZS 3000 tells us that the cross-sectional area of every current-carrying conductor shall be such that the voltage drop between the point of supply for the low voltage installation, and any point in that electrical installation does not exceed 5% of the nominal voltage at the point of supply. That means all the cables from the point of supply to the final point in any sub-circuit. Unless an installation is specifically designed to take account of a specific volt drop, the wiring to all low voltage supply points (sub-circuits) shall ensure that the drop in voltage shall not exceed 2.5% of the standard voltage.

When this is applied to the standard voltages of 230 volts and 400 volts, you get permissible voltage drop (v.d.) values of:

Single-phase 230 V:

$$2.5/100 \times 230 = \mathbf{5.75 \text{ V}}$$

Two- and three-phase 400 V:

$$2.5/100 \times 400 = \mathbf{10.0 \text{ V}}$$

Determining minimum cable size based on voltage drop

To satisfy the voltage drop limitations of a circuit, it is necessary to consider the current required by the load and the route length of the circuit. This is done by determining the:

- current (I) requirements of the circuit
- route length (L) of the circuit
- maximum voltage drop (v.d.) permitted on the circuit run.

Example

$$V_d = \frac{(L \times I \times V_c)}{1000}$$

V_c = the millivolt drop per ampere-metre route length of circuit in millivolts per ampere metre (mV/A.m)

V_d = actual voltage drop

L = route length of circuit, in metres

I = the current to be carried by the cable, in amperes.

Refer to Tables 40 to 50 of AS/NZS 3008, and note that the right-hand section gives various volt drop values in millivolts (volts/1000) per ampere per meter;

This means that the V_d in millivolts is stated for each ampere of load current carried *and* for each meter of cable length. If the stated value is, say, 35 mV per ampere per meter, then a 3 phase cable carrying 6 A over a distance of 20 meters will have a V_d along its length of:

$$V_d = \frac{(35 \times 6 \times 20)}{1000} = 4200mV \text{ or } 4.2V$$

The following example looks at how all this can be applied to a cable requirement

Example

A single-phase 230 V 15 A circuit with close protection is to be run 25 meters. You would like to use a 2.5 mm² TPS, 75°C cable and clip it to a wall. Column 2 in Table 4 gives a current rating of 34 A for this cable, which is adequate for this circuit. Remember as a rule-of-thumb that the *maximum V_d for 230 V is 5.75 V*.

You would calculate the V_d as follows:

Table 42 gives a V_d value of **15.6** millivolts per ampere per meter for this cable.

$$\begin{array}{c}
 \begin{array}{ccc}
 \text{From Table} & \text{Current} & \text{Length of run} \\
 \swarrow & \swarrow & \swarrow \\
 & & \text{Converts to single phase value} \\
 & & \swarrow \\
 V_d \text{ for } 2.5\text{mm}^2 = & \frac{(15.6 \times 15 \times 25 \times 1.155)}{1000} \\
 & \uparrow \\
 & \text{Converts mV to volts} \\
 & \\
 & = \mathbf{6.76 \text{ V}}
 \end{array}
 \end{array}$$

This V_d exceeds the maximum of 5.75 volts for this 230V circuit. Therefore, this size of cable is unsuitable.

You must therefore look for a cable that has a larger cross-sectional area and hence, a lower V_d value. The table shows that the next larger sized cable is 4 mm², and the V_d given in Table 42 is **9.71** millivolts per ampere per metre.

$$\begin{array}{c}
 \text{Lower number because bigger cable} \\
 \downarrow \\
 V_d \text{ for } 4.0\text{mm}^2 = \frac{(9.71 \times 15 \times 25 \times 1.155)}{1000} \\
 \\
 = \mathbf{4.2 \text{ V}}
 \end{array}$$

This value is below the maximum of **5.75V**, and so your choice of cable is **4mm² twin TPS**.

Example

Using the details in the above example, what sized three-core cable would you use to deliver a 400 V 15 A balanced three-phase supply with close protection to a sub-board 25 meters away? Cable is 75°C unenclosed but fixed to a surface.

Solution

Look at Table 13 (Column 5). A 2.5 mm² conductor is probably suitable, because its current rating of 25A is above the required 15 A.

The V_d for this cable is 15.6 millivolts per ampere per meter.

$$\begin{aligned} V_d \text{ for } 2.5\text{mm}^2(3\Phi) &= \frac{(15.6 \times 15 \times 25)}{1000} \\ &= \mathbf{5.85 \text{ V}} \end{aligned}$$

This value is below the rule-of-thumb maximum V_d of 10.0V allowable for a three-phase circuit, and so you can conclude that a cable of 2.5 mm² cross-sectional area would be suitable.

In practice, you may have considered using 1.5 mm² for this circuit because it is rated at 17A. However, a calculation would show that the volt-drop would be above the permissible value.

The 10 volts allowable volt drop for a three-phase circuit applies only to a balanced load such as a three-phase motor.

In unbalanced circuits, the greatest value of line current must be used in the calculation of volt drop.

The above examples illustrate the need to be sure that not only is the cable current rating observed, but the volt drop as well. Some other factors may also need to be considered, and we will deal with them next.

Cable Selection Worked Example

A **three-phase, 400V, copper, mains cable** is being installed in an electrical installation comprising 4 houses, a milking shed and out-buildings.

The customer is to be provided with the best solution that meets the technical requirements. Use the following information and information from AS/NZS3008 to calculate the size of cable required.

Installation information

- Installation Route: 50m length between the point of supply and the main switchboard
- Installation Method: Buried direct
- Maximum Demand: 70kW balanced over the three phases
- Voltage Drop: Maximum permitted voltage drop is 1.5%
- Growth Allowance: An allowance of 15% for load growth
- Environment: The ambient soil temperature is 20°C
- Conductor Supplier Information: Conductor temperature of 75°C
- Indicate the correct answer for each section. Show workings where applicable.

- a) Calculate the maximum demand current of the installation before the allowance for growth.

$$I = \frac{P}{(\sqrt{3} \times 400)}$$

$$I = \frac{70000}{(\sqrt{3} \times 400)}$$

$$I = 101.04A$$

- b) Calculate the current demand after the allowance for load growth required. Please show workings.

$$\text{Load Growth} = \frac{15}{100} \times 101.4 = 15.156A$$

$$\text{Total Load Needed} = 101.4 + 15.156 = 116.2A$$

c) What size of cable would satisfy this current demand?

From Table **13** (page 63), Column **23**, Buried Direct, the rating for 25mm² is **138A**

So, for current carrying capacity a **25mm²** would be sufficient.

d) What is the value of de-rating factor for the ambient temperature?

We need to look at **Table 27(2)** on page **88** for the (de)rating factor for soil ambient temperatures. The soil this cable is buried in, has a temperature of 20°C.

For a 75°C cable the ratings are

- 10°C – 1.04
- 15°C – 1
- 20°C – 0.95

As we can see, as the temperature goes up, the rating decreases, which decreases the amount of current the cable can take.

Our cable is rated at 138A. If it was in 15°C temperature, the rating wouldn't change as the factor is 1.

If it was 10°C, it would actually increase the rating of the cable.

It would be able to carry $138 \times 1.04 = \mathbf{143.52A}$

The temperature for our cable though is set in soil that is **20°C**, and so this will de-rate the cable. The amount it can carry will decrease.

It would be able to carry $138 \times 0.95 = \mathbf{131.1A}$

131.1A is still greater than the 116.2A load and so the **25mm²** would still be sufficient.

Volt Drop

We now need to check that the volt drop is within the percentage allowed.

We're allowed 1.5% of 400V

$$\left(\frac{1.5}{100}\right) \times 400 = 6V$$

The minimum mV/A.m allowed can be calculated by

$$\begin{aligned} \text{Min } mV/A.m &= \frac{\text{Volt drop allowed} \times 1000}{\text{current} \times \text{length of run}} \\ &= \frac{(6 \times 1000)}{(116.2 \times 50)} = 1.032702 \end{aligned}$$

We now need to look at Table **42** (Page **110**), column **6**, to find a cable size that has a value greater than this.

The **25mm²** cable that satisfies the current carrying capacity has a value of **1.54** and so this is not low enough. The cable size that has a value less than 1.032702 is **50mm²** and so this would have to be used.

Worked example for selecting cables sizes

The figure below represents a 230V single phase electrical installation operating at standard low voltage

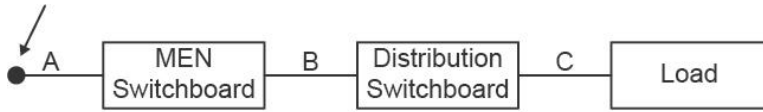

Cable A - <u>consumer mains</u>	Voltage drop	1.97V - (Point Of Supply)
Cable B – <u>submain</u>	Size	10mm ² Cu
	Load	40 A
	Length	25 metres
Cable C – <u>final sub-circuit</u>	Size	1.5mm ² Cu
	Load	15 A
	Length	15 metres

Each cable has a maximum conductor temperature of 75°C.

Each cable is protected by a Type C circuit breaker.

- i) Using the information in the preamble and information from the tables, calculate the total voltage drop of the entire circuit, from start of point of supply (A) to the end of cable C

Method

From **Table 42**, single phase conversion

factor is **1.155 Submains**

$$\begin{aligned}
 V_d &= \frac{V_c \times L \times I \times 1.155}{1000} \\
 &= \frac{3.86 \times 25 \times 40 \times 1.155}{1000} \\
 &= \mathbf{4.46V}
 \end{aligned}$$

Final subcircuit

$$\begin{aligned}
 V_d &= \frac{V_c \times L \times I \times 1.155}{1000} \\
 &= \frac{28.6 \times 15 \times 15 \times 1.155}{1000} \\
 &= \mathbf{7.43V}
 \end{aligned}$$

Total voltage drop

$$= 1.97 + 4.46 + 7.43 = \mathbf{13.86V}$$

- ii) The voltage drop you have calculated in (i) for the circuit does not comply with the regulatory requirements

Refer to the relevant standards or regulation and determine by calculation, why the voltage drop does not comply.

Method

The voltage drop must not be more than 5% under maximum load conditions between the point of supply and;

- (a) any socket outlet within an installation operating at standard low voltage, or
- (b) the supply terminals of any fixed-wired appliance connected to an installation operating at standard low voltage.

AS/NZS 3000:3.6.2

ESR 61(4)

Permitted voltage drop

$$= 5\% \times 230 = 11.5 \text{ V}$$

The installation does not comply as the total voltage drop is **13.86 V**

- iii) the most practical way to reduce the volt drop is to increase the size of cable A or cable B or cable C.

Alter the size of one of the cables, and recalculate the voltage drop to confirm it meets the regulatory requirements.

Method

Increase the size of cable C to 2.5mm²

$$\begin{aligned} V_d &= \frac{V_c \times L \times I \times 1.155}{1000} \\ &= \frac{15.6 \times 15 \times 15 \times 1.155}{1000} \\ &= 4.05V \end{aligned}$$

Total voltage drop

$$\begin{aligned} &= 1.97 + 4.46 + 4.05 \\ &= 10.48V \end{aligned}$$

Acceptable voltage drop is within 5%

Class of excess-current protection

An important point to remember is that the cable ratings given in Tables A1 to A5 are for close (fine) protection. That is, the ratings are for cables which are protected by circuit-breakers or high-rupturing-capacity (HRC) fuses, which will interrupt the circuit within 4 hours at 1.5 times their rated current.

If cables are protected by some form of coarse protection, (fuses which ensure the protection will only operate after 4 hours at a current of 1.5 times the device's rated current), then the current ratings given need to be de-rated by multiplying them by $1/1.33$ or 0.75 .

Surge protection

Surge protection is required to protect systems against sudden power surges:

- **Coarse protection** provides protection to the electrical system against lightning or a major fault such as a surge from a grid malfunction or an accident. Coarse protection units are generally installed in the meter box.
- **Medium protection** provides protection from voltage surges or brownouts (low or under-voltage supply). Medium protection units are generally installed in the meter box or distribution board.
- **Fine protection** offers the best protection and is used to protect a specific appliance or group of appliances. It is also the most expensive option. It is typically a plug-in module such as an uninterruptable power supply (UPS). The appliance is not directly connected to the mains but only receives power from the UPS.

Ambient temperature

ESR 2010:9 specifies ambient temperature.

AS/NZS 3000:2007: Table C5 refers to 1Φ applications for cables in different ambient temperatures – where ambient temperature means the temperature of the medium in the immediate neighbourhood of the installed cable:

- a) Including any increase in the temperature due to materials or fittings to which the cables are connected, or are to be connected; but
- b) Excluding any increase in temperature, which may be due to the heat arising from the cables at that point.

In other words, ambient temperature, as it applies to cables, is the temperature of the air surrounding the cables when the cables are not loaded. Ambient temperature influences the current rating of cables because it affects the cable insulation temperature. Ambient temperature is detailed in AS/NZS 3000:2007:3.3.2.1.

Derating must be implemented where temperatures fall outside the limits specified. This should be done in conjunction, using manufacturer's specification, AS/NZS 3000:2007 and AS/NZS 3008 as applicable.

Example

A 2.5 mm² PVC cable has a current rating of 18 A and is protected by a circuit-breaker. The ambient temperatures are 25°C and 65°C. Use the rating factors to find the appropriate current rating for each situation.

Solution:

$$\begin{aligned} \text{New current rating for 25°C} &= 18 \times 1.06 \\ &= \mathbf{19.08A} \text{ (Uprated)} \end{aligned}$$

$$\begin{aligned} \text{New current rating for 65°C} &= 18 \times 0.35 \\ &= \mathbf{6.3 A} \text{ (Derated)} \end{aligned}$$

Example

In the previous example, what would the current ratings for 25°C and 65°C be, if the cable was covered by XLPE sheathing?

Are the cables uprated or derated?

Solution:

$$\begin{aligned} \text{New current rating for 25°C} &= 18 \times 1.04 \\ &= \mathbf{18.72 A} \end{aligned}$$

$$\begin{aligned} \text{New current rating for 65°C} &= 18 \times 0.65 \\ &= \mathbf{11.7 A} \end{aligned}$$

At 25°C the cable is uprated. At 65°C the cable is derated. Note the difference that the type of cable sheathing makes.

Installation methods

You have already looked at the derating of cables in circumstances where the voltage drop may be excessive, or the ambient temperature may be greater than 30°C. Another reason to derate cables is to allow for the physical position or the installation method. For example, cables might be:

- clipped direct to a surface
- unenclosed in air
- enclosed conduit in air
- partially enclosed in thermal insulation
- buried directly in soil.

If you refer to Tables 3.1 and 3.2 of AS/NZS 3000:2007 you will see that in most cases, the current-carrying capacity of a certain size of cable, varies with the physical position or the installation method.

Let's take the example of a conductor size of 2.5 mm² and consider the table below.

At an ambient temperature of 30°C, these cables, when supplying a single-phase load, will carry the following maximum currents:

Type of installation	Maximum current carrying capacity (amps)
Clipped direct	28
Unenclosed in air	28
Enclosed conduit in air	24
Partially enclosed in thermal insulation	20

When the flow of air around the cable is reduced, the maximum current carrying capacity is also reduced.

Derating factor

You must apply the derating factor when several circuits are run together. This is because, when a group of cables are run together, the heat may be produced more quickly than it can be dissipated. Accordingly, the current rating of a cable in a group must be derated so that the heat produced may be dissipated without undue temperature rise, and the insulation temperature may be kept within its correct limits. As the number of cables in a group increases, so the derating factor decreases. Refer to AS/NZS 3000:2007:C 6.1.

Example

Three 2.5 mm² twin and earth TPS cables are to be enclosed in conduit. Find the maximum current rating of the cable when close protection is used, and a grouping factor of 0.7 is applied.

Solution:

AS/NZS 3008: Table 4. (Column 15): States that the current rating of 1Φ 2.5 mm² enclosed in conduit is 27 amps.

AS/NZS 3008: Table 22. (Column 6): As there are 3 circuits, there is a derating factor of 0.7.

$$\begin{aligned} \text{Modified current rating} &= 27 \times 0.7 \\ &= \mathbf{16.1 \text{ A}} \end{aligned}$$

This is the maximum current rating of the cable.

Cables in contact with thermal insulation

Many installations require cables to be installed, in cavities or walls in which thermal insulation is used to reduce heat loss from buildings. By its very nature, thermal insulation prevents the loss of heat, and so cables installed in this material must be derated because the heat from fully loaded cables cannot escape. The diagram below shows the installation.

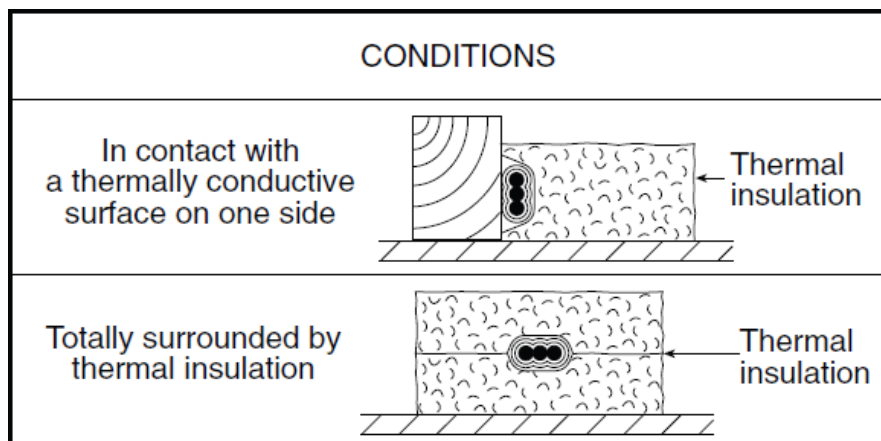

Summary

When selecting cable sizes for an installation, always refer to manufacturers' data and to appropriate *Standards*.

Use the following procedure to select cables:

- Assess the required current rating of the sub-circuit.
- Decide on a suitable cable type and the method of installation, for example, TPS cable clipped to a surface or wire in conduit.
- Refer to the appropriate cable current ratings in the tables and select one.
- Multiply your initial selection by any rating factors that apply, for example, 'bunched together' or 'ambient temperature'.
- Calculate the voltage drop from the tables — given in millivolts per ampere per metre.
- Ensure that the voltage drop in the circuit does not exceed 2.5% or 5% according to the circumstances of the supply voltage, that is, 5.75 volts or 11 volts for single-phase 230 volts, or 10 volts or 20 volts for two- or three-phase 400 volts.
- If the voltage drop exceeds the maximum allowed, try a cable with a larger cross-sectional area.
- If the voltage drop is *well below* the maximum allowed and economy is an important factor, try a cable with a smaller cross-sectional area.

Determine a cable conductor size by:

- markings on the cable sheathing
- labels on the cable drum or box
- measurement of the conductor.

Protecting cables against damage

You have already learned that cables must be electrically protected — that is, a cable needs to have protection such as a fuse or circuit-breaker to ensure that its current rating is not exceeded.

You have also learned that cables must be protected from excess temperature. There are other forms of damage that cables must also be protected from. If they are not installed correctly for the conditions in which they operate, cables may suffer from:

- mechanical damage
- fire or explosion
- corrosion.

Protecting cables against mechanical damage

The main points are that:

- All cables, including underground cables, must be adequately protected against any risk of mechanical damage.
- Normally, the only cables allowed in a lift shaft are those forming part of the lift installation.
- Cables installed under floors, must be positioned in such a way that they are not liable to be damaged by the floor or its fixings.
- Where cables pass through metal, the hole must be smooth-edged to prevent abrasion of the cable.
- Cables that are bent too sharply, can suffer from mechanical damage due to compression at the inner radius, and stretching at the outer radius of the bend.

Selecting flexible cords

When dealing with flexible cords you should be able to:

- describe the construction of flexible cords
- identify common flexible cords
- select a suitable flexible cord for a certain job.

Operating conditions

The operating conditions for flexible cords may range from very light duty to heavy duty under heat, water, oil, low temperatures, and mechanical stress. For example, most flexible cords in use today are PVC sheathed. PVC is excellent for most purposes but, as you have learnt, can shatter at temperatures below 0°C. PVC cords should not, therefore, be used in freezing chambers. Rubber flexible cords are suitable for freezing chambers but are not suitable in oily situations.

High-temperature PVC, or rubber flexible cords should be used where cords enter heating appliances or are to be used for the internal wiring of heaters. Flexible-cord manufacturers can advise you of the suitability of their product, for any application and will supply all data required.

Conductors, because of their resistance, produce heat when current passes through them. In certain circumstances, such as when ambient temperatures are high, cords must be *derated* so that the conductors and insulation are not damaged by excessive heat. The simplest solution is to use a flexible cord one size larger than normal. The larger cord is then carrying far less than the current it was designed for and has therefore been derated.

Extension cords on reels can overheat during prolonged use. When a long extension cord is wound on a reel, any heat generated in the inner turns cannot easily escape. The result is a build-up of heat that may damage the insulation of the inside turns. To prevent overheating, either reduce the current rating of the extension cord, or ensure that the cord is fully unwound from the reel before use.

Tension on flexible cords, if excessive, can cause damage to the cord. Flexible cords supporting light fittings, for example, are inclined to suffer from tension damage if the light fitting is too heavy.

The maximum weight of a light fitting that can be suspended on a length of flexible cord is 3 kg for 0.75 mm² flex, and 5 kg for 1 mm² flex. As the figure shows, heavy fittings must be suspended by a metal rod, tube, or chain of adequate strength.



Number of cores

An appliance that has only basic insulation and has a metal enclosure must be earthed and must have a three-core cord.

An appliance that is double insulated or fully insulated should have a two-core cord.

Current rating

The current drawn by a heating appliance through its flexible cord can be calculated using the following formula

Current in amperes = power in watts divided by volts

When a flexible cord is wound on a drum, the current-carrying capacity must be de-rated by the following factor.

Number of layers:	1	2	3	4
Derating factor:	0.76	0.58	0.47	0.4

The current-carrying capacity is based on a cable maximum operating temperature of 60°C, in order to avoid overheating.

Typical current ratings for cords are

- 1mm² = 10A
- 1.25 mm² = 13A

Example

What size of flexible cord would you use for a 230 V electric heater rated at 2400 W?

$$\begin{aligned}
 \text{Current in amperes} &= \frac{\text{power in watts}}{\text{volts}} \\
 &= \frac{2400}{230} \\
 &= \mathbf{10.4A}
 \end{aligned}$$

A 1.25 mm² conductor is rated at 13 amperes, and so this is a suitable size for this appliance.

Example

A range is rated at 2.0 kW. What size of flexible cord would you use to supply this appliance?

$$\text{Current} = \frac{2000}{230} = 8.7A$$

A flexible cord of 1.0 mm² is suitable. It has a rating of 10 amperes, which is a suitable size for this appliance. Because each of these examples are heating appliances and require earthing, you would use high-temperature three-core flexible cords.

Voltage drop

Voltage drop in a conductor, reduces the available voltage at an appliance. If the supply voltage is 230 volts and the voltage drop in the cord is 10 volts, then the appliance receives only 220 volts and operates less efficiently.

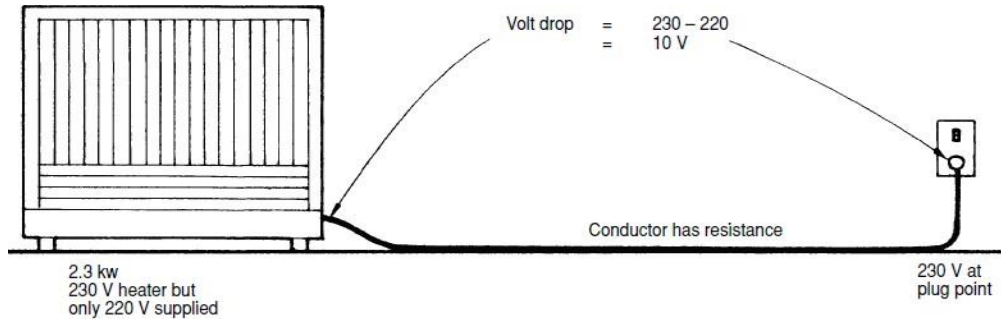

From electrical energy and power calculations, that power is proportional to the square of the voltage across any resistance.

$$P = \frac{V^2}{R}$$

$$P \propto \frac{V^2}{R}$$

Therefore, a small drop in voltage at the terminals of an appliance can cause a significant reduction in the power supplied to it.

The 230V 2.3 kW heater shown above, would receive only 220V which is only 0.956 of the supply voltage with which it should have been supplied.

However, it would produce only, (from $P \propto V^2$) 0.92 or 92% of rated power output.

This is as a result of the voltage drop over the length of the cord.

The remaining 8 per cent is lost through the cord in the form of heat. The solution, in this case, is to fit a larger flexible cord (greater cross-sectional area). This would reduce both the voltage drop, and the heat produced in the conductors. If the appliance was a machine that included a motor (for example, a concrete mixer operated from an extension cord), the problem of voltage drop in the cord could be more serious.

Induction motors

Induction motors are very sensitive to supply voltage changes. A small reduction in voltage could cause a great deterioration in an induction motor's performance.

If this happened, the motor would never run up to speed and would draw excess current in its attempt to drive the load. The extension lead might be damaged by overheating, and the motor could burn out if its overload device was not set correctly.

Aim for a voltage drop of **less than 2.5% of 230 volts (5.75 volts)**, which is the maximum voltage drop allowable along the flexible cord.

Ideally, you should not have a voltage drop, but because all conductors have resistance, *keep flexible cords and extension leads as short as possible*. If in doubt, *use the next biggest conductor size*.

Calculating voltage drop

Generally, flexible cords are standardised at lengths of two or three meters for most appliances, and provided the current ratings are correct for the load, voltage drop is seldom a problem.

However, it can be a problem when long extension cords are used.

The volt drop can be found by multiplying the number of millivolts (mV) by the number of amperes of current that the appliance draws, and then multiply by the number of meters in the length of the flexible cord.

Example

An extension cord 30 meters long is to be made up. The appliance it will operate will draw 6 A. What cord size is suitable?

Try the 1.0 mm² again. The figure for 1.0 mm² is 43 mV per ampere per meter.

$$\begin{aligned} \text{Voltage drop} &= \frac{(43 \times 6 \times 30)}{1000} \\ &= 7.75V \end{aligned}$$

This is above the maximum allowable, 5.75 volts. Let's look at 1.5mm². The figure for 1.5 mm² is 31 mV per ampere per meter.

$$\begin{aligned} \text{Voltage drop} &= \frac{(31 \times 6 \times 30)}{1000} \\ &= \mathbf{5.58V} \end{aligned}$$

This size will just do the job, and this example shows the importance of considering voltage drop when making up long lengths of cord. We have to use a cord with almost three times the current rating required, in order to overcome voltage drop.

Summary

- When you choose a flexible cord, consider the
 - operating conditions
 - number of cores
 - current rating
 - voltage drop.

- Use the appropriate documentation to find / calculate
 - current rating
 - voltage drop.

- Excessive voltage drop in a flexible cord causes the appliance it supplies to run less efficiently.

- Induction motors are very sensitive to voltage variations, and voltage drop must be kept to a minimum.

- Heat is generated when flexible cords are wound onto reels. Always unwind a cord that is to be fully loaded.

Maximum Demand

In this resource, we have spoken about the demand or maximum demand on cables. AS/NZS 3000: Clause 2.2.2, states that maximum demand current can be determined by one of four methods—calculation, assessment, measurement or limitation.

It should be recognized that different installations of the same type may have significantly different load profiles, which must be considered. The methods provided in AS/NZS 3000 have been used over several editions of AS/NZS 3000 and, providing that care is taken to assess the presence of unusual equipment loads, are considered appropriate for many typical applications.

When the load is assessed, and the current-carrying capacity of the circuit is determined by allowing for diversity of operation of equipment, then the circuit should be protected by a circuit-breaker of the appropriate rating, to comply with requirements.

For the purposes of this unit, we have and will provide the maximum demand for any calculations although you will be expected to calculate the current load for certain applications such as a motor load or heat load. You will not be assessed on calculating Maximum Demand for an installation with diverse loads. That is a topic that will be covered later in your studies.

Harmonic Currents and Cable Current Carrying Capacity

These days, non-linear loads are becoming a bigger part of the electrical load in industrial and commercial power systems, such as solid-state energy conversion devices, traction drives industrial variable speed drives, and arc welding equipment.

Non-linear loads generate harmonics in line currents, resulting in additional conductor heating. This heating results in a higher temperature rise of the cable, if it is not sized to carry the harmonic currents. To include the effects of harmonics, the frequency spectrum of the load, has to be known.

In three phase star connected electrical power distribution systems with neutrals, sinusoidal line currents are symmetrical resulting in zero neutral current, whereas line currents with harmonics such as those supplying non-linear loads result in non-zero neutral currents due to the summation of zero sequence currents in the neutral conductor.

Harmonics generated by non-linear loads decrease the quality of power supplied and cause a de-rating of the cable due to the increased load current.

Consider a three-phase circuit with a design load of 40 A to be installed using four-core PVC insulated cable clipped to a wall. From Table 13 in AS/NZS 3008, a 6 mm² cable with copper conductors has a current carrying capacity of 42 A and is for this load suitable if harmonics are not present in the circuit. If however 20% third harmonic is present then a reduction factor of 0.86 is applied and the design load becomes:

$$\frac{40}{0.86} = \mathbf{47\ A}$$

For this load, we would need a 10mm² cable.

If a 44% third harmonic is present, the cable size selection is based on the neutral current, which is:

$$40 \times 0.44 \times 3 = \mathbf{52.8\ A}$$

and a reduction factor of 0.86 is applied, leading to a design load of:

$$\frac{52.8}{0.86} = \mathbf{61.4\ A}$$

For this load, we would need a 16mm² cable.

If 50% third harmonic is present, the cable size is again selected based on the neutral current, which is:

$$40 \times 0.5 \times 3 = \mathbf{60\ A}$$

In this case, the reduction factor is 1 and a **16mm²** cable is suitable.

All the above cable selections are based on the current-carrying capacity of the cable only. Voltage drop and other aspects of selection have not been considered.

Short Circuit Performance

Short circuit currents increase the current on the cable dramatically. This increases the cable temperature to a point where it may exceed the permissible maximum temperature. This will result in a need to de-rate the cable and thus require an increased cable size for the installation.

The following adiabatic method is used to calculate the permissible conductor and metallic sheath short-circuit currents for the majority of practical cases and any error is on the safe side. The generalized form of the adiabatic temperature rise equation, which is applicable to any starting temperature, is as follows:

$$I^2t = K^2S^2$$

Where:

I = short-circuit current (r.m.s. over duration), in amperes

t = duration of short circuit, in seconds

k = constant depending on the material of the current-carrying component, the initial temperature and the final temperature

S = cross-sectional area of the current-carrying component, in square millimetres

We can also use the formula to calculate a minimum cable size. During a short circuit, a high amount of current can flow through a cable for a short time. This surge in current flow, causes a temperature rise within the cable. High temperatures can trigger unwanted reactions in the cable insulation, sheath materials and other components, which can prematurely degrade the condition of the cable.

As the cross-sectional area of the cable increases, it can dissipate higher fault currents for a given temperature rise. Therefore, cables should be sized to withstand the largest short circuit that it is expected to see.

The minimum cable size for a given type of cable due to short circuit temperature rise is typically calculated with an equation of the form:

$$S = \frac{\sqrt{I^2t}}{k}$$

Where:

S = cross-sectional area of the cable (mm²)

I = the prospective short circuit current (A)

t = the duration of the short circuit (s)

k = the short circuit temperature rise constant

Example

Consider a Thermosetting 900C (XLPE) cable with copper conductors. There is a maximum fault current of 13.6kA which causes the cable temperature to rise to 250°C and the protective device to trip within 2.6 seconds. Determine if a cable size of 300mm² is adequate.

The constant k can be found from table 52 of AS/NZS3008 using the starting temperature of 90°C and final temperature of 250°C. In this instance k = 143.

Using the formula:

$$S = \frac{\sqrt{I^2 t}}{k}$$

$$S = \frac{\sqrt{13600^2 \times 2.6}}{143} = \mathbf{154mm^2}$$

This means that any cable greater than **154mm²** will be adequate for the installation. As the cable size chosen is **300mm²** this will be more than adequate.

Example

Determine, using the adiabatic equation, the minimum size of conductor for the following.

- 70°C Thermoplastic, PVC cable
- Temperature rise to 160°C which gives k = 115
- Fault current of 18779A
- Disconnection time of 1.5 seconds

Using the formula:

$$S = \frac{\sqrt{I^2 t}}{k}$$

$$S = \frac{\sqrt{18779^2 \times 1.5}}{115} = \mathbf{200mm^2}$$

A cable greater than **200mm²** would be adequate for this situation.

Earth Fault Loop and cable size

A basic safety requirement stated in AS/NZS 3000 is the protection of people from 'indirect contact' with live parts. Automatic disconnection of the power supply is the most common way of satisfying this requirement. However, there is a bit more to it than that.

To comply with the Wiring Rules each circuit in an electrical installation must be designed such that automatic disconnection of the power supply occurs within a specified time when a short-circuit of negligible impedance occurs between the active and protective earth conductor or other exposed conductive part anywhere in the electrical installation.

To fulfil this requirement of AS/NZS 3000, when a fault occurs, the impedance of the fault current path (referred to in the Wiring Rules as the Fault Loop Impedance Path) must be low enough to allow sufficient current to flow to ensure the protective device will operate within the specified time.

The earth fault loop in an MEN system comprises the following components:

- The protective earthing conductor (PE). The objective of the earth fault loop impedance calculation is to properly determine earth cable size.
- The neutral return path consisting of the neutral conductor (N) between the main neutral terminal and the transformer neutral point.
- The path through the transformer winding.
- The active conductor (A) as far as the point of the fault.

The diagrams on the following pager show the current path in a correctly operating circuit (top) and the current path in a circuit with an earth fault.

Current path in a correctly operating circuit

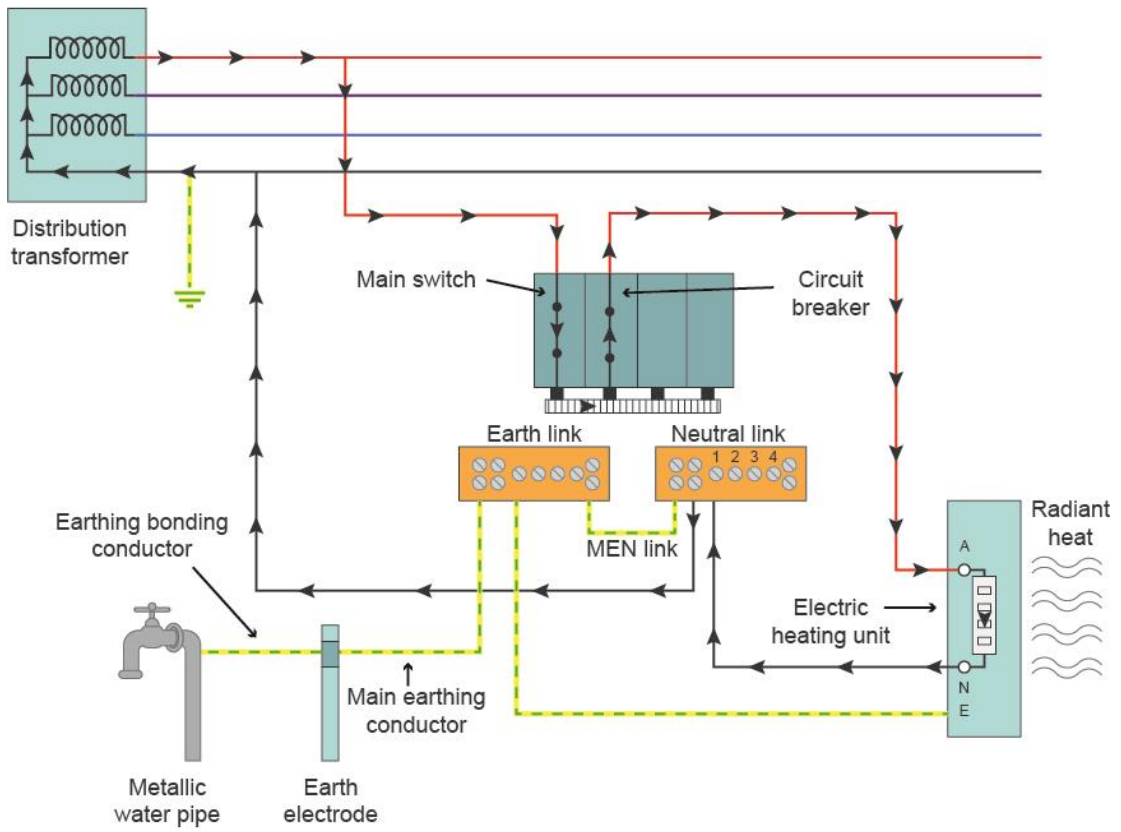

Current path in a circuit with an earth fault

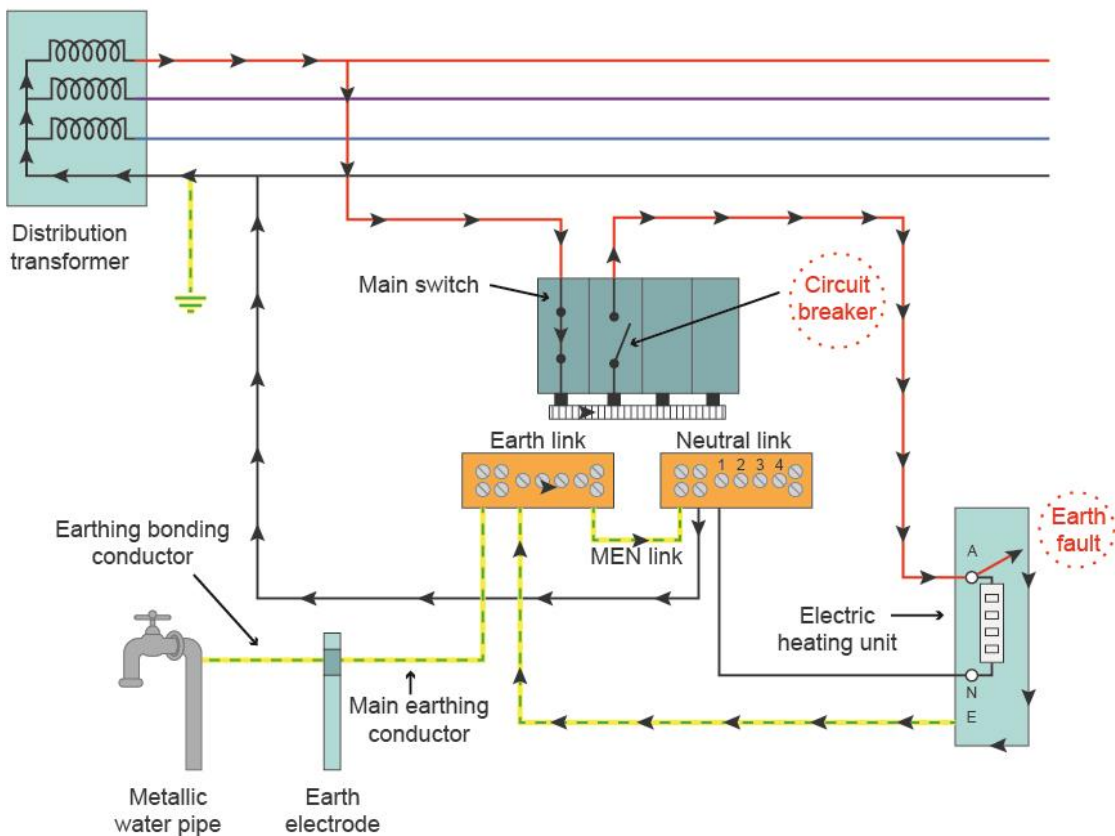

Total earth fault loop impedance

The total earth fault loop impedance is approximately equal to the sum of impedances of all of the circuit components in the fault loop impedance current path shown in the diagram on the previous page.

An accurate method of determining impedance of the conductors in the earth fault loop path is to use the resistance and reactance data given in AS/NZS 3008.1 – Electrical Installations – Selection of Cables.

Fault Loop Impedance compliance requires that if an active to earth fault occurs then the total impedance in the fault loop path (consisting of all conductors, connections and contacts as well as the transformer windings) must be low enough to allow sufficient fault current to flow in order to operate the circuit protective device within an adequate time.

Therefore, it must be ensured that the actual earth fault loop impedance (Z_{in}) be less than the maximum permissible (Z_s). The value of Z_{in} is determined by adding together the impedances of the earth fault loop.

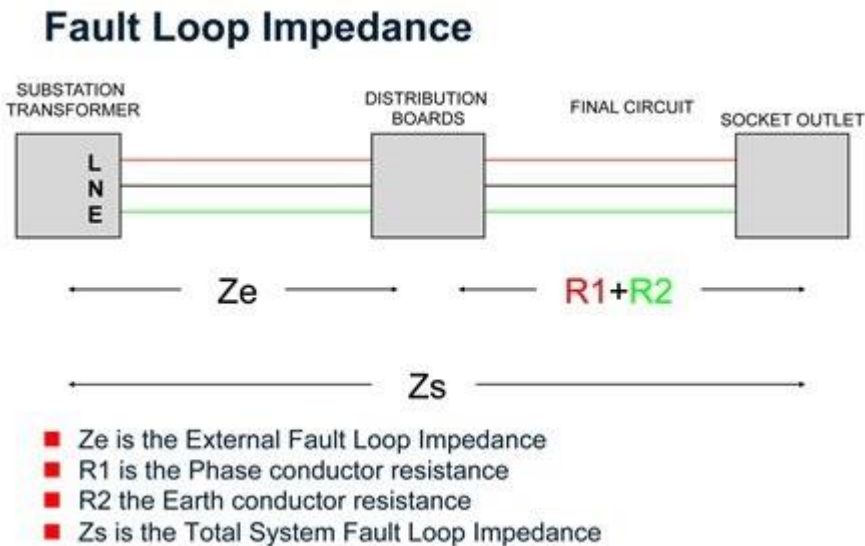

The actual value Z_{in} is calculated using: $Z_{in} = Z_e + (R_1 + R_2)$

Example

An installation has an external fault loop impedance (Z_e) of **1.5Ω**. The phase conductor resistance (R_1) is **0.4Ω** and the earth conductor resistance (R_2) is **0.3Ω**.

Determine the total earth fault loop impedance of the system and indicate the correct answer below

$$Z_{in} = Z_e + (R_1 + R_2)$$

$$Z_{in} = 1.5 + (0.4 + 0.3) = \mathbf{2.2 \Omega}$$

Maximum earth fault loop impedance

The maximum value Z_s is calculated using:

$$Z_s = \frac{U_o}{I_a}$$

Where:

Z_s = Maximum earth fault loop impedance

U_o = Nominal phase voltage

I_a = Current ensuring automatic operation of the protective device

I_a for circuit is the mean tripping current as follows:

Type B= 4 x rated current

Type C= 7.5 x rated current

Type D= 12.5 x rated current

The value of Z_s may be used to calculate the appropriate earth cable size in terms of AS/NZS 3000: Section 5.7.4. However, Table 8.1 in AS/NZS 3000 provides these values.

What must be clearly understood is that the earth cable size needs to be sufficient to ensure:

- Appropriate earth fault loop impedance (Z_{in}).
- Adequate current-carrying capacity for prospective earth fault currents for a time at least equal to the tripping time of the associated circuit protection (adiabatic equation in the previous section on short circuits).
- Adequate mechanical strength.

The selection of the earth cable size is determined from either:

- Tables in AS/NZS 3000 which provide conservative earth cable sizes with relation to the largest active cable size (or summation where there are parallel circuits).
- By calculation – this requires the protective device details to be known.

In reality, the tables in AS/NZS 3000 and AS/NZS 3008 are conservative and as long as you select a cable in accordance with these requirements, and your cable selection calculations are accurate, your earth conductor will be sized correctly.

Maximum Demand

The cable size chosen for an installation doesn't have to be able to carry the full loading of everything supplied. This is because it is assumed that not all appliances, lights, heating and cooking appliances will be used at the same time.

Table C1 of AS/NZS 3000:2007 sets out the maximum demand factors for single and multiple domestic electrical installations.

For instance, if an installation had 25 socket outlet points, each able to supply 10A, if you didn't factor in maximum demand the current rating for these alone would be $25 \times 10 = 250A$!

Table C1 says that we need to allow 10A for the first 20 socket outlets and then 5A for each 20 (or part of 20) after that.

So, for our 25 outlets, we would need to allow for

- 10A for first 20 outlets
- 5A for the remaining 5
- Total demand for outlets would be $10 + 5 = 15A$

Let's look at an installation with the following loads

- 30 points of lighting
- 1250W of outdoor lighting
- 25 x 10A socket outlets
- 2kW cooking appliances
- 1kW of space heating
- 1.5kW instantaneous water heater

You will need to refer to Table C1 of AS/NZS 3000:2007 for the following explanation

30 points of lighting

This comes under Load Group A of Table C1

From column 2 of Table C1 we need to allow 3A for points 1-20 and then 2A for each additional 20

$30 \text{ points} = 3A \text{ for first } 20 + 2A \text{ for remaining } 10 = 3 + 2 = 5A$

1250W of outdoor lighting

This also falls under Load Group A

From column 2 we need to allow for 75% of the connected load

$$75\% = \frac{75}{100} = 0.75$$

$$0.75 \times 1250W = 937.5W$$

We need to convert this power into amps

$$I = \frac{P}{V}$$

$$I = \frac{937.5}{230} = 4A$$

25 x 10A socket outlets

This comes under Load Group B of Table C1

From column 2 of Table C1 we need to allow 10A for points 1-20 and then 5A for each additional 20

$$25 \text{ points} = 10A \text{ for first } 20 + 5A \text{ for remaining } 5 = 10 + 5 = 15A$$

2kW cooking appliances

This comes under Load Group C of Table C1

From column 2 of Table C1 we need to allow 50% of the load

$$50\% = \frac{50}{100} = 0.50$$

$$0.5 \times 2000W = 1000W$$

We need to convert this power into amps

$$I = \frac{P}{V}$$

$$I = \frac{1000}{230} = 4.35A$$

1kW space heating

This comes under Load Group D of Table C1

From column 2 of Table C1 we need to allow 75% of the load

$$75\% = \frac{75}{100} = 0.75$$

$$0.75 \times 1000W = 750W$$

We need to convert this power into amps

$$I = \frac{P}{V}$$

$$I = \frac{750}{230} = 3.26A$$

1.5kW instantaneous water heater

This comes under Load Group E of Table C1

From column 2 of Table C1 we need to allow 33.3% of the load

$$33.3\% = \frac{33.3}{100} = 0.333$$

$$0.333 \times 1500W = 499.5W$$

We need to convert this power into amps

$$I = \frac{P}{V}$$

$$I = \frac{499.5}{230} = 2.17A$$

We now just need to add up all of the currents to find the maximum demand

$$\text{Maximum Demand} = 5 + 4 + 15 + 4.35 + 3.26 + 2.17 = 33.78A$$

We can now specify a cable capable of carrying 33.78A.

The table on the following page shows typical current carrying capacities.

Current Carrying Capacity

Conductor Size mm ²	Current Carrying Capacity (A)
1	13
1.5	16
2.5	23
4	30
6	39
10	54
16	72

Looking at the table, we would need to specify a 6mm² cable as its capacity (39A) is the closest one above our maximum demand of 33.78A. The 4mm² capacity is too low (30A)

Volt Drop

The last thing we have to do is to make sure that the cable volt drop does not exceed the maximum allowable.

In this instance the maximum volt drop is 2.5% of 230V = 5.75

We can use the following table to calculate the volt drop of our specified cable given that the cable run is 20m.

Conductor Size mm ²	mV/A.m
1	51.63
1.5	33
2.5	18
4	11.2
6	7.5
10	4.46
16	2.8

Volt Drop Calculation

We know that

$$\text{Volt Drop} = \frac{(mV/A.m \times I \times L)}{1000}$$

$$\text{Volt Drop} = \frac{(7.5 \times 33.78 \times 20)}{1000}$$

$$\text{Volt Drop} = 5.067V$$

This is below the allowable volt drop of 5.75V and so the 6mm² cable is still sufficient for this installation.



Te Pūkenga

earnlearn-tepukenga.ac.nz

0800 327 648 (0800 EARN IT)