



# Learning resource

Demonstrate knowledge of electric switchboards

Level 4 | Credits 3



Te Pūkenga



# Contents

Part 1: Functions of switchboard components and circuits .....	1
Components of a Switchboard .....	3
Frame .....	3
Bus .....	3
Instrumentation .....	4
Meters .....	5
Protective Devices .....	5
Example Switchboard .....	7
Control Circuits .....	11
Part 2: Switchboard construction and installation requirements .....	17
Low Voltage Switchgear and Control Assembly (Assembly) .....	17
Type Tested Low Voltage Switchgear and Control Gear Assembly (TTA).....	17
Partially Type-Tested Low Voltage Switchgear and Control Gear. Assembly (PTTA) .....	18
Parts of an Assembly .....	18
Commercial Switchboards .....	19
Types of Assemblies.....	19
Switchboards .....	20
General Construction of Switchboards .....	20
Busbar Arrangements.....	21
Control and metering equipment.....	22
Markings and Equipment Identification .....	22
Wiring .....	23
Access to Live Parts .....	24
Maximum Prospective Fault Current Condition .....	24
Fire-Protective measures.....	25
Switchboard Location and Accessibility Requirements .....	27
Switchboard Location and Environment.....	27
Ventilation.....	27
Accessibility .....	27
Restricted locations and General Positioning.....	28

Identification of the Main Switchboard .....	29
Ventilation .....	29
Installation of RCD on Switchboards .....	30
Arrangement .....	31
Part 3: Switchboard schematic diagram.....	32
Switchboard Schematic.....	32
Cable Size Calculation .....	33
Part 4: Potential for electrical interference .....	34
Means of Preventing Common Sources of Electrical Interference on Low Voltage Signals with Reference to the Minimum Installation Requirements to Eliminate Interference. ....	35
Cable Alignment.....	36
Shielded Cable .....	36
Cable Routing .....	36
Earthing.....	37
Cable Resistance .....	37
Power Cables.....	37
Cable Alignment of Power Cables .....	38
Cables with Non-Ferrous Metal Sheathing .....	38
Cable Proximity.....	39
The Proximity Effect .....	39
Radio Signals .....	40
Fast Switching Power Electronic Devices.....	41
How to Reduce the Effects of EMI .....	42
Part 5: Consumer metering.....	43
Purpose of Metering Equipment .....	43
Types of Metering Installations – Low Voltage.....	44
Typical Three Phase Whole Current Metering .....	46
Typical Whole Current Metering with Load Control.....	47
Typical Metering Neutral Connection Arrangements.....	48
LV CT Metering.....	49
High voltage metering.....	50
Distributed Generation and Import / Export Metering .....	50
Load Control Devices .....	51
Energy Meter Types .....	51

---

Location of Metering Equipment .....	51
Location on Domestic Premises.....	51
Meter Enclosures .....	53
Residential Meter Enclosures .....	53
Commercial Meter Enclosures .....	53
Metering Alterations.....	53
Demolishing an ICP .....	54



# Part 1: Functions of switchboard components and circuits

Under Section 2.9 of the AS/NZS 3000-2007, an electrical installation must include a switchboard for the mounting or the enclosure of switchgear and protective devices and including the main switch or switches.

The example (right), shows a switchboard with two sections, an incoming or service section, and a distribution section that provides power to feeder and branch circuits. Circuit breakers mounted in these sections provide overcurrent protection. Some switchboards use fusible switches instead of circuit breakers

The function of a switchboard is to divide the main current provided to the switchboard into smaller currents, for further distribution and to provide switching, current protection, and metering for these various currents.

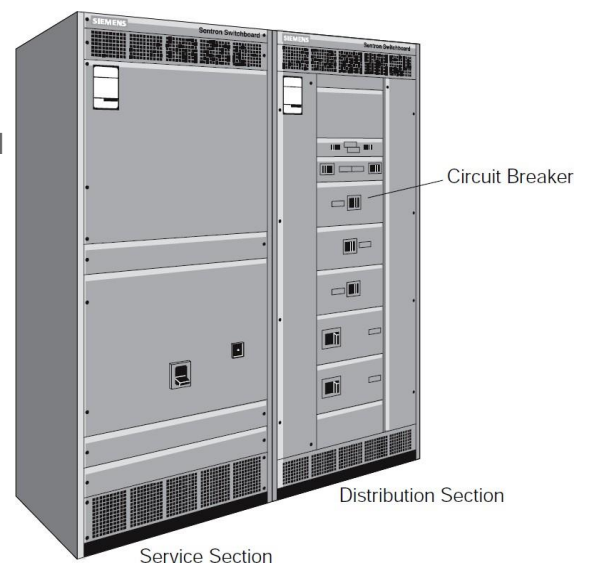

Power distribution systems used in residential buildings and commercial and industrial facilities, are

more complex than those used in single-family homes and must be capable of handling higher levels of current and voltage. The diagram on the next page is an example of a complex power distribution system.

The switchboard is a large single panel, frame, or assembly of panels on which are mounted, on the face, back, or both, switches, overcurrent and other protection devices, buses, and usually instruments.

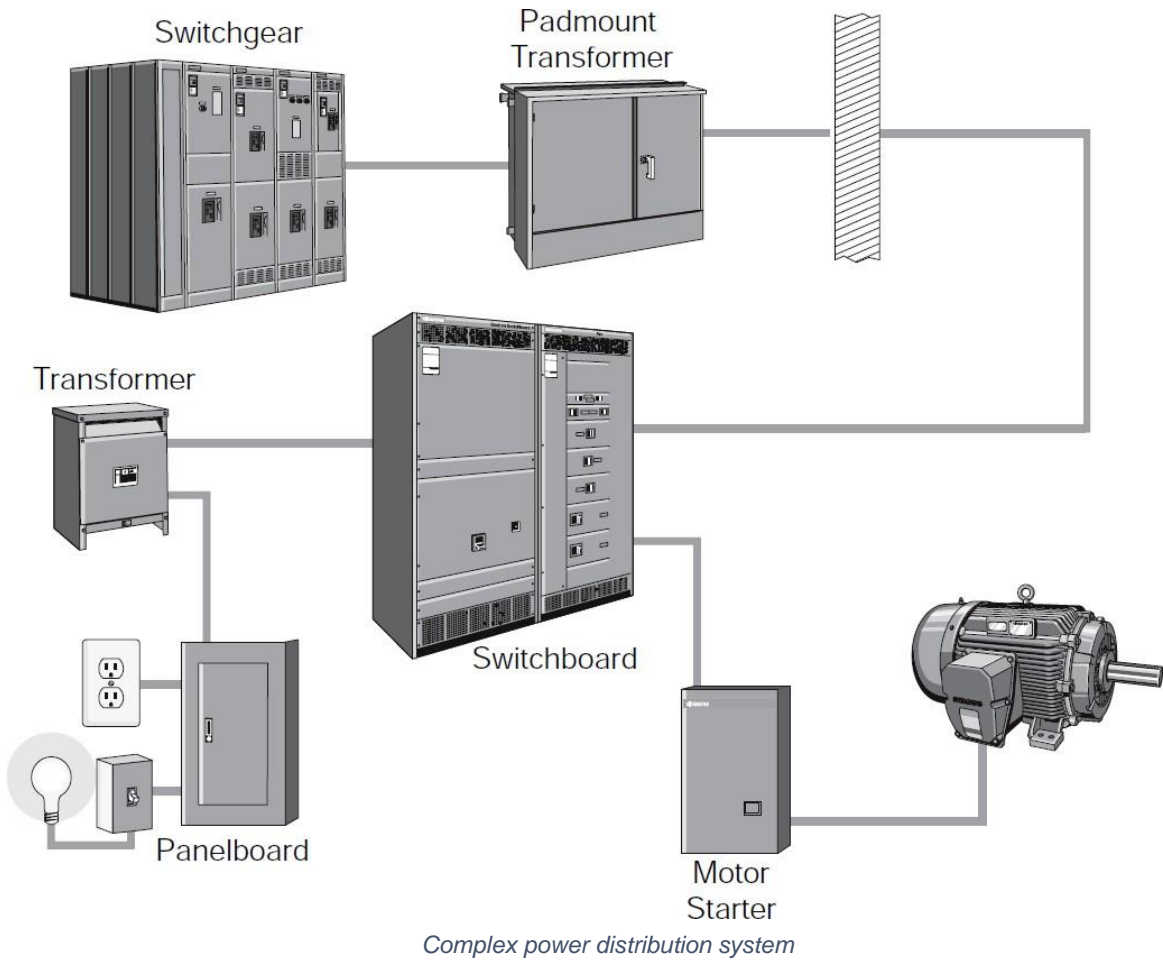

# Components of a Switchboard

The basis for a switchboard consists of a frame, bus, Overcurrent Protective Devices, instrumentation, and exterior covers.

## Frame

The frame is the metal skeleton in which the other components reside.

## Bus

The bus are metal bars mounted within the frame to conduct power to the switchboard's devices and is used to distribute power

Horizontal Bus distribute power to each switchboard section. Vertical Bus distribute power through the circuit protection devices to the branch circuits.

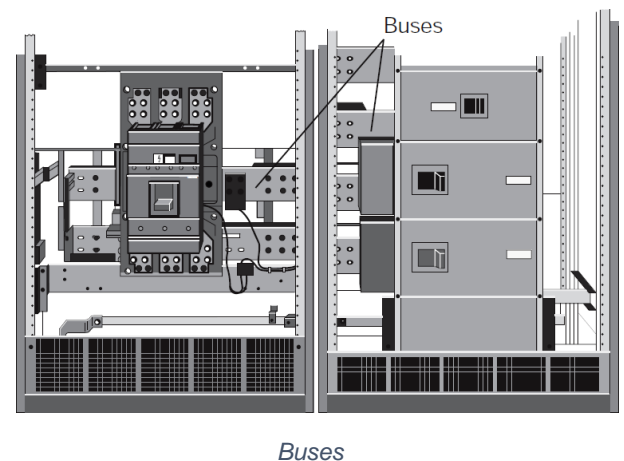

## Instrumentation

The switchboard may also have instrumentation. This instrumentation often includes one or more meters designed to accept signals from sensors and other equipment and display representative values for power monitoring and management.

Other instrumentation on a switchboard could include:

- Ammeter
- Voltmeter
- Power monitor
- HMI – human machine interface
- RTU – remote telemetry unit
- Surge protection devices and monitor

## Switchgear

Switchgear is the combination of electrical disconnect switches, fuses or circuit breakers used to control, protect and isolate electrical equipment. Switchgears are used both to de-energise equipment to allow work to be done and to clear faults downstream.

One of the basic functions of switchgear is protection, which is interruption of short-circuit and overload fault currents, while maintaining service to unaffected circuits. Switchgear also provides isolation of circuits from power supplies. Switchgear is also used to enhance system availability by allowing more than one source to feed a load.

A switchgear has two types of components:

Power conducting components, such as switches, circuit breakers, fuses, and lightning arrestors, that conduct or interrupt the flow of electrical power.

Control systems such as control panels, current transformers, potential transformers, protective relays and associated circuitry, that monitor, control, and protect the power conducting components.

## Meters

Meters can be used in the service section to measure current, voltage, power usages, peak demands just to name a few.

## Protective Devices

There are four types of protective devices commonly used in switchboard applications. These are:

### Power “air” circuit breaker

The term “power” is applied to a large circuit breaker with a range of adjustable magnetic overcurrent and solid, state trips. It does not have a thermal trip. It is built on an open framework for servicing and adjustment. It can be manually or electrically operated and is available with ratings up to 4000 amperes.

Power air circuit breakers can be stationary-mounted or draw-out type. Draw-out breakers can be tested without removal from the switchboard.

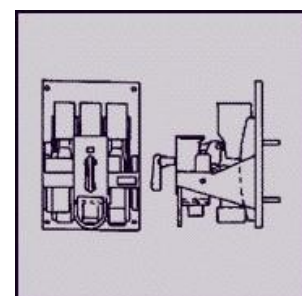

wide  
It does  
easy

out

### Moulded case circuit breaker

This breaker is normally both a thermal and magnetic trip device. Ratings run 15 – 2,500 amps, with a variety of short circuit interrupting capacities.

Some breakers feature interchangeable trip elements. Others have solid state trip units.

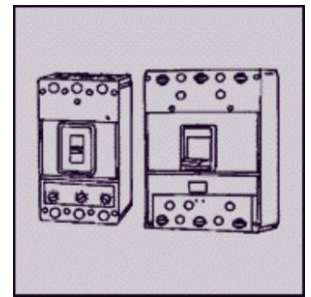

### Fusible switch

This is a hand-operated disconnect switch with a fuse on each pole. When an overload condition arises, the fuse link melts and opens the pole, protecting the circuit.

Fuses are available in two styles. The “time delay” fuse is suitable for load surges, such as motor start-ups. The “instantaneous” fuse is designed to “clear” in a fraction of a second in the event of a high current short circuit. They are typically in rated for 240- 600v and 15- 1200 amps.

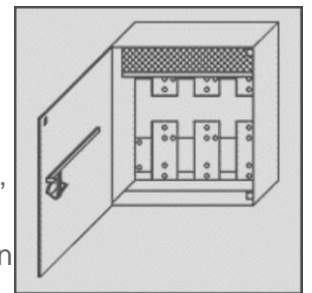

The main difference between a circuit breaker and a fusible switch, is that the circuit breaker can be reclosed after an overload has been interrupted and corrected. The fuse needs to be replaced.

### Bolted pressure switch

This switch type is primarily used for service entrance and feeder circuits. The switch is quick-make/quick-break. When the switch moved to the ON position, the line contacts are squeezed together under pressure by the contact locking mechanism. This stored up energy is released for quick make. The same energy quickly breaks the contacts when the manual trip button is pushed.

The protective elements are heavy duty, current-limiting high interrupting capacity fuses. Bolted pressure switches are rated 240-480 volts and 800 – 4,000 amps.

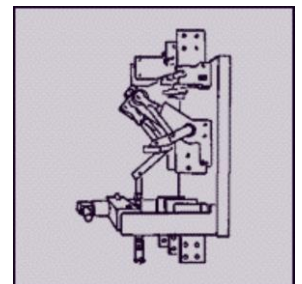

Accessories are available to open the switch automatically or remotely. It can be manual or an electric trip.

## Example Switchboard

The following is a three phase 500A capacity switchboard supplying three stories. Each story is on a single phase.

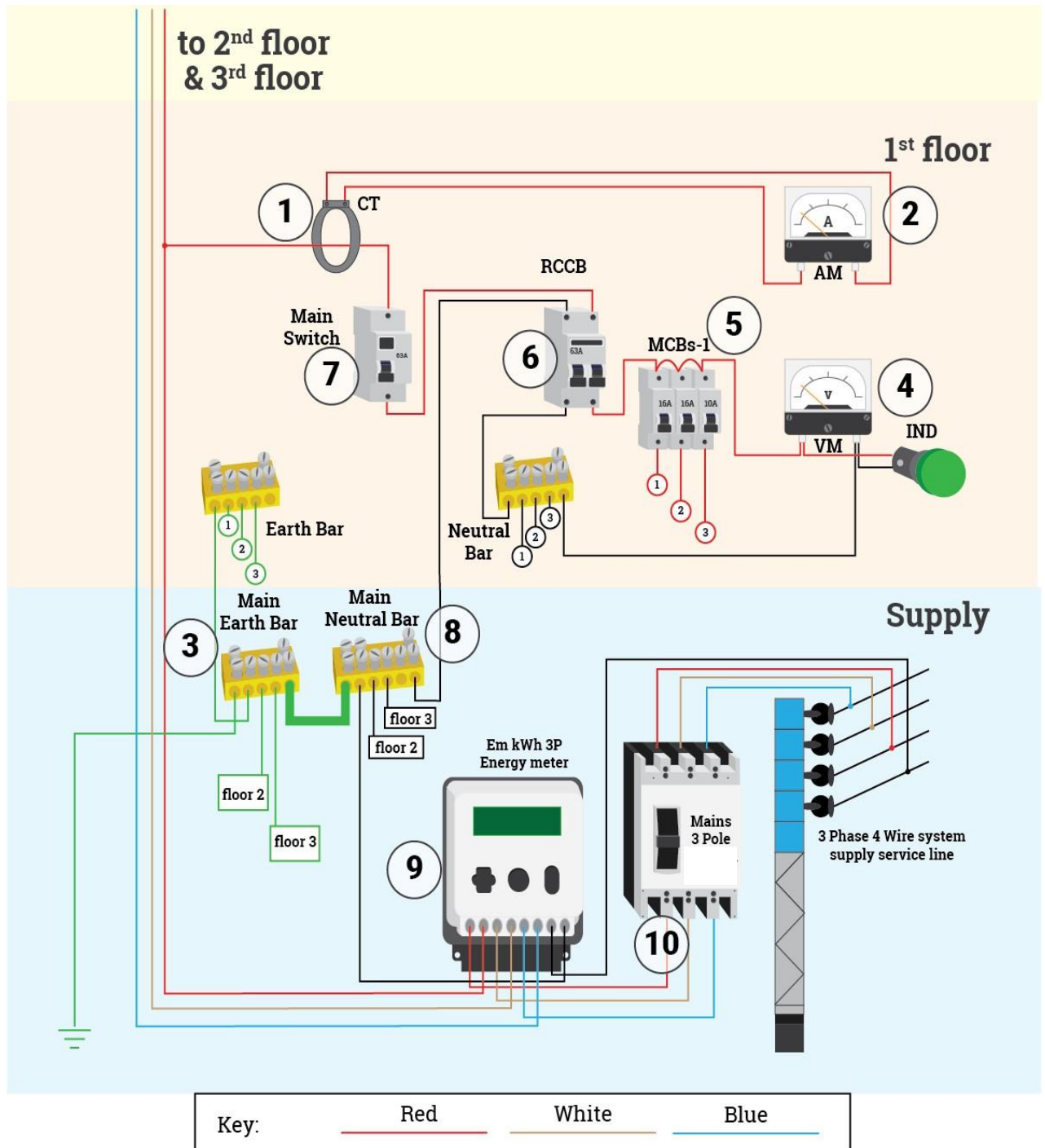

The following section looks at the components of the switchboard and their functions

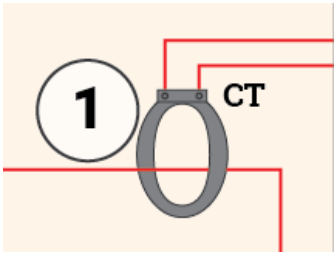
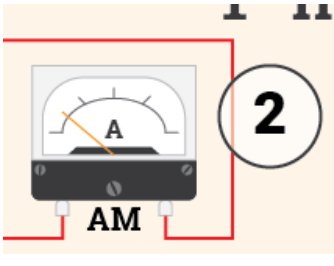
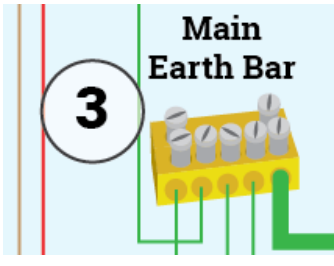
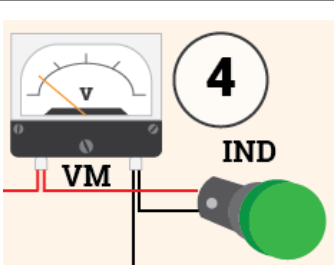
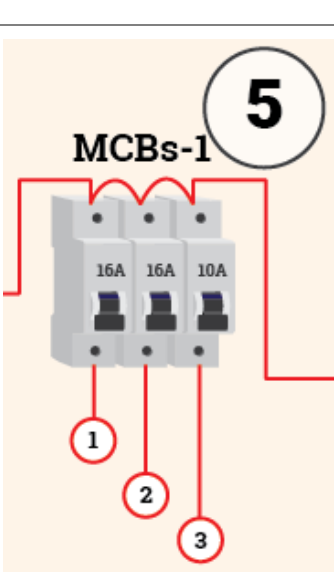
Component	Name and function
	<p>This is a current transformer. The actual current flowing in the circuit would be too high and dangerous for an ammeter to measure and so the current transformer lowers the value of current safer level. A typical 1A output could be read by a panel mounted ammeter.</p>
	<p>This ammeter is fed from the CT and gives an indication of the current flowing in this part of the installation. Although the input would only be a maximum of 1A, the scale would be calibrated to indicate the actual current flow.</p>
	<p>This is the main earth bar. It is the connection point of the main earthing conductor and the various protective earthing conductors. It is linked to the main neutral bar by means of a removable MEN link</p>
	<p>This is a voltmeter. It will give a direct reading of the voltage in that part of the system. It is connected across the input to the MCB and the neutral bar.</p>
	<p>This is an MCB (Miniature Circuit Breaker). It protects individual circuits using a combination of thermal and magnetic trips. In this circuit it is fed from an RCCB.</p>

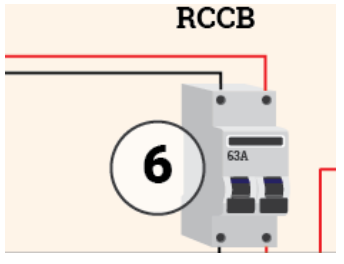
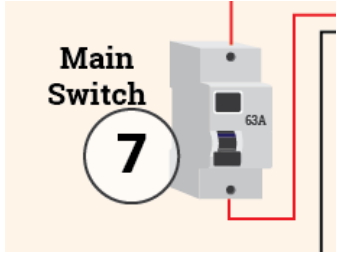
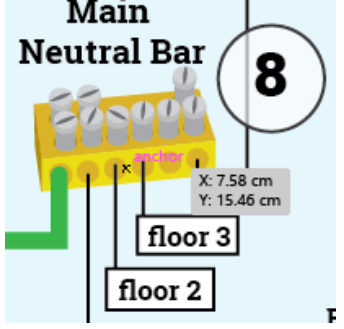
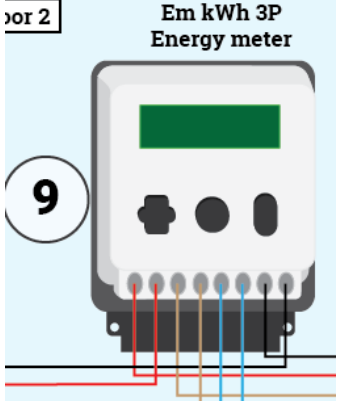
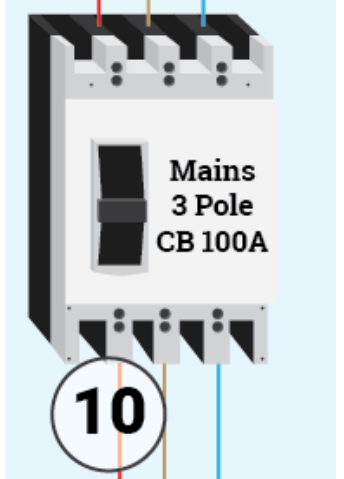
 <p><b>RCCB</b></p> <p>6</p>	<p>This is an RCCB (Residual Current Circuit Breaker). It provides earth leakage protection for the user. It will trip if there is an imbalance in the phase and neutral currents in the circuit.</p>
 <p><b>Main Switch</b></p> <p>7</p>	<p>This is a single pole circuit breaker that provides protection for this part of the installation. It can also be used to isolate that part of the circuit (the single story)</p>
 <p><b>Main Neutral Bar</b></p> <p>8</p> <p>X: 7.58 cm Y: 15.46 cm</p> <p>floor 3</p> <p>floor 2</p>	<p>This is the main neutral bar. It is used for the connection of the main (incoming) neutral to neutral conductors supplying RCDs and circuits not on RCD protected circuits</p>
 <p><b>Em kWh 3P Energy meter</b></p> <p>9</p>	<p>This is a three phase energy meter (kWh meter). It measures the kWh usage for the whole installation.</p>
 <p><b>Mains 3 Pole CB 100A</b></p> <p>10</p>	<p>This is the main 3 pole circuit breaker. It provides protection and isolation for the entire installation.</p>

The installation can be categorised in terms of the following.

**a) Main power distribution system**

The main power distribution system consists of incoming overhead 3-phase supply and neutral to the main 3 pole circuit breaker via the energy meter. From this point, power (active and neutral) is supplied to each story or floor of the building as a single-phase supply to the sub distribution boards except where it is included in the main switchboard for the first story or floor.

**b) Associated protective devices**

These devices made up of a main breaker for each sub-distribution board or sector providing service to each floor, RCCB protection and MCB's for individual circuit protection are installed to provide protection to the user.

**c) Metering**

In this instance, a 3-phase energy meter is used to measure energy use for the whole installation.

# Control Circuits

The following circuit diagram shows a number of different control circuits fed from a single phase supply.

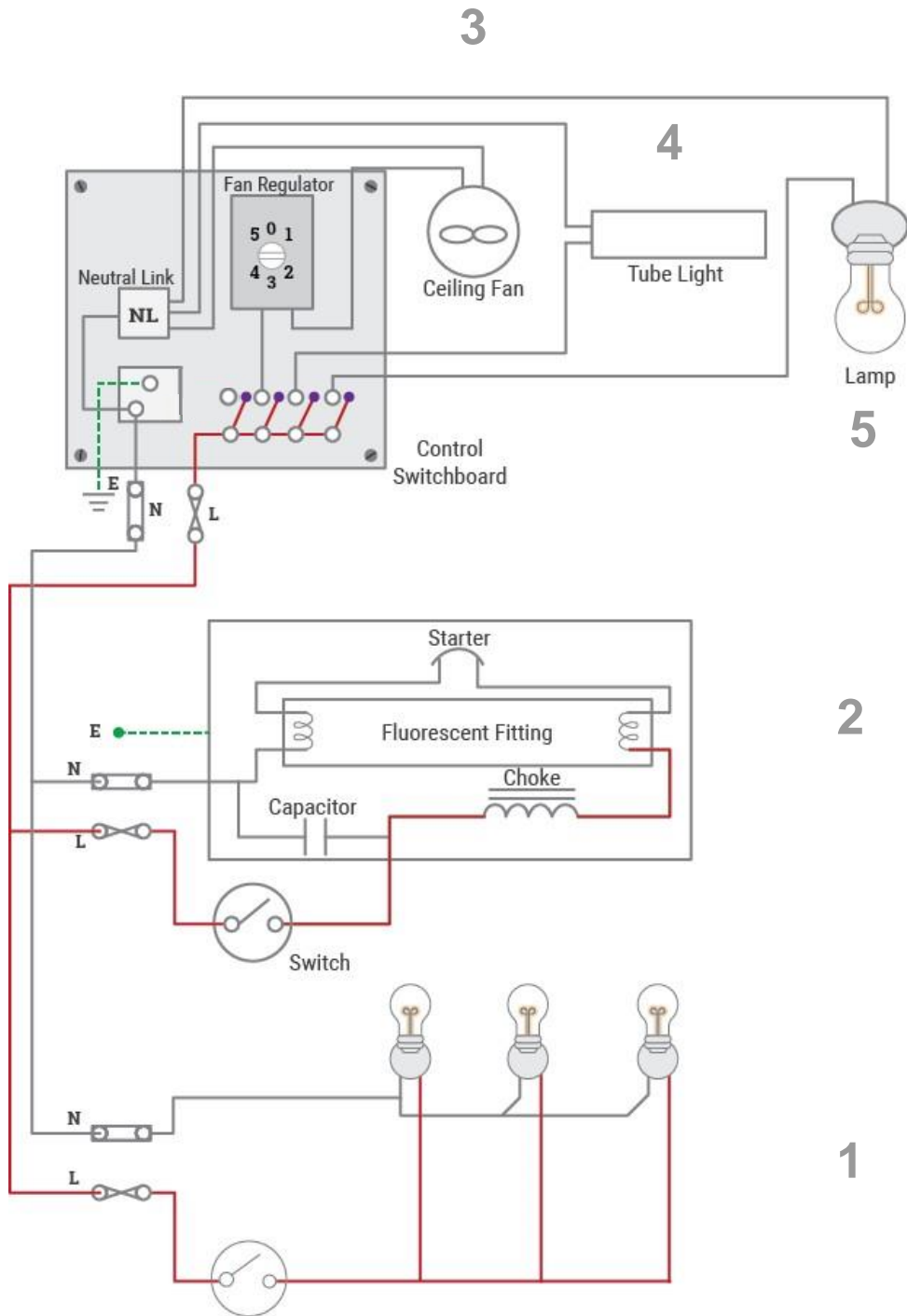

**Circuit 1**

This is a simple one-way lighting circuit which uses a one-way switch to control three lamps. The lamps are connected in parallel.

**Circuit 2**

This circuit also uses a one-way switch to control a fluorescent fitting.

**Circuit 3**

A ceiling fan is fed from a one-way switch within a control switchboard via a fan regulator.

**Circuit 4**

A one-way switch within the control switchboard controls a tube light

**Circuit 5**

A single lamp is controlled by a one-way switch within the control switchboard

The followings pages show some other example circuits

## Example 1: Small Office Building

A small office building might require 230 volts for interior lighting and receptacles and 400 volts for heating, air conditioning, and exterior lighting. The utility company supplies 400/230 volt, three-phase, four-wire service.

The main incoming line is divided into four feeders. The two outer feeders supply power directly to the 400 volt heating and air conditioning units. The two inner feeders are divided into several branch circuits. One set of branch circuits supplies power to exterior lighting. The second set of branch circuits supplies power to interior lighting and receptacles. This is shown in the diagram below.

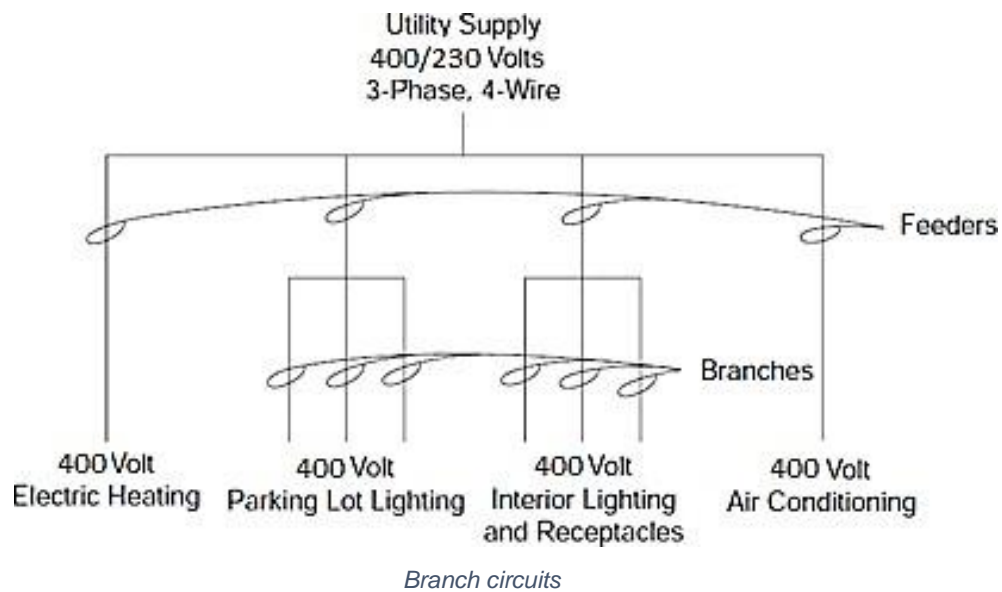

The electric utility uses a step-down transformer to supply power to a facility. There are several ways the secondary of the utility transformer could be configured. In the following example, the utility supplies power from a transformer with a star connected secondary. The secondary winding of the transformer produces 400/230 VAC. Single-phase 230 VAC is available between any phase wire and neutral. Single-phase 400 VAC is available between any two phases. All three phases are connected to any equipment requiring three-phase power.

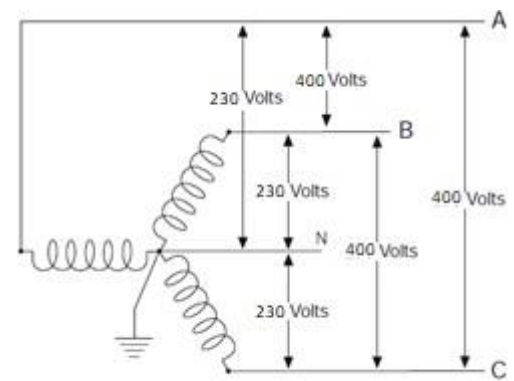

*Transformer configuration*

Incoming power is metered by the utility company. In this example, power is supplied to the building through a main service disconnect. A switchboard divides the power into four feeders for distribution throughout the building.

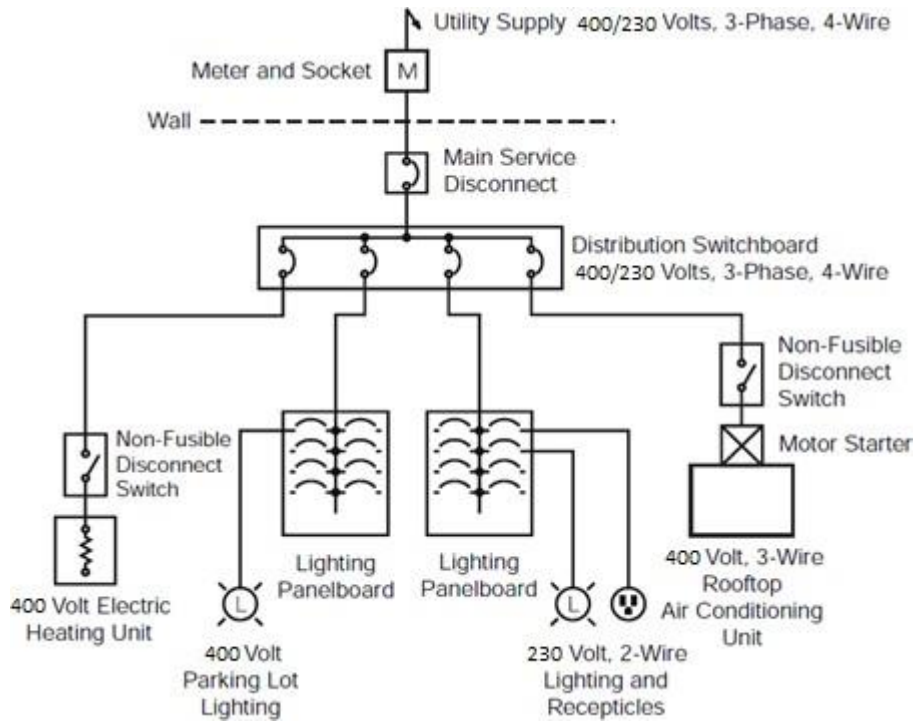

Switchboard

## Example 2: Medium-Sized Industrial Plant

The incoming power is provided by a 400/230 VAC, three-phase, four-wire system.

Three feeders are used. The first feeder is used for various types of power equipment. The second feeder supplies a group of 400 VAC motors. The third feeder is used for 230V lighting and receptacles. See the example below:

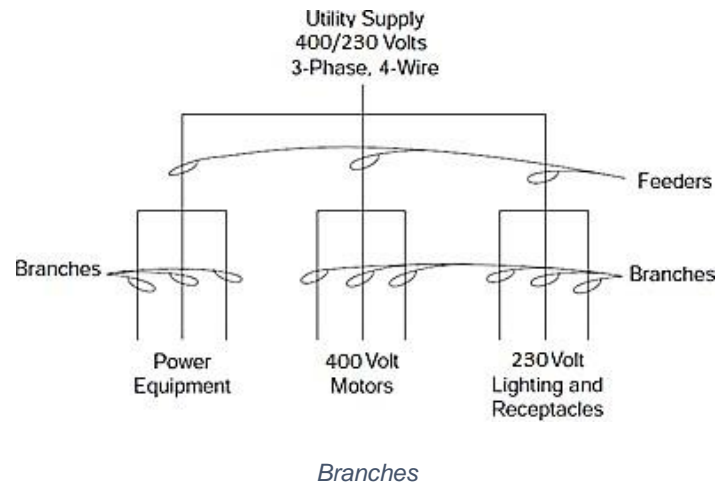

The secondary winding of the utility transformer provides the 400/230 VAC needed to power the system, as shown in the diagram opposite

The power from the utility company is metered and enters the plant through a distribution switchboard. The switchboard incorporates a main circuit breaker and circuit breakers for each of the three feeders.

The feeder on the left powers a distribution switchboard, which, in turn, feeds a panelboard and a 400 volt, three-phase motor.

The middle feeder powers another switchboard which divides the power into three, three-phase, three-wire circuits. Each circuit feeds a busway run to 400 volt motors. The feeder on the right supplies 400/230 volt power to panelboards connected to lighting and receptacles. See the example on the next page:

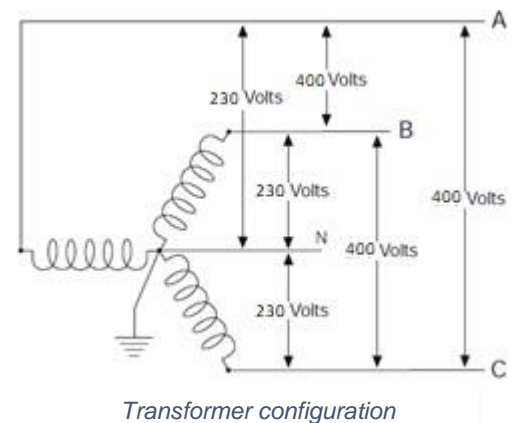

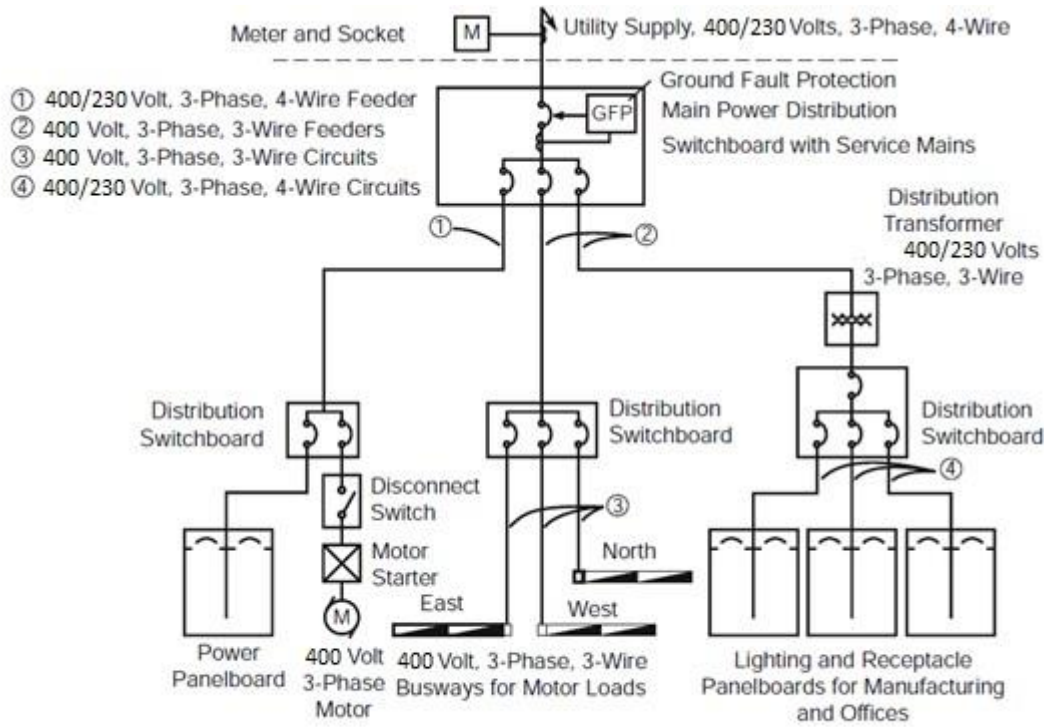

Switchboard

# Part 2: Switchboard construction and installation requirements

Before we go into the details of switchboard construction, let us look at the various types of ASSEMBLIES.

## Low Voltage Switchgear and Control Assembly (Assembly)

The abbreviation 'ASSEMBLY' is used for low-voltage switchgear and control gear assembly. This is a combination of one or more low-voltage switching devices, together with associated control, measuring, signalling, and protective, regulating equipment. The components of the ASSEMBLY may be electromechanical or electronic.

It is completely assembled under the responsibility of the manufacturer with all internal electrical and mechanical interconnections and structural parts. To allow for transporting or production requirements, certain steps of the ASSEMBLY may be made in a different location from the manufacturer factory.

## Type Tested Low Voltage Switchgear and Control Gear Assembly (TTA)

TTA is a low voltage switchgear and control gear assembly, conforming to an established type or system without deviations, likely to significantly influence the performance, from the typical ASSEMBLY verified, to be in accordance with standard.

To allow for transporting or production requirements, certain steps of the ASSEMBLY may be made in a different location from the manufacturer factory of the TTA. Such an ASSEMBLY is considered as a TTA provided the ASSEMBLY is performed in accordance with the manufacturer's instructions in such a manner that compliance of the established type or system is assured according to standard, including submission to applicable routine tests.

## Partially Type-Tested Low Voltage Switchgear and Control Gear Assembly (PTTA)

This is a low-voltage switchgear and control gear ASSEMBLY, containing both type-tested and non- type-tested arrangements, provided that the latter are derived (e.g. by calculation) from type-tested arrangements which have complied with the relevant tests.



### Parts of an Assembly

The **main circuit** (of an ASSEMBLY) is all the conductive parts of an ASSEMBLY included in a circuit which is intended to transmit electrical energy.

Auxiliary circuit (of an ASSEMBLY), is all the conductive parts of an ASSEMBLY included in a circuit (other than the main circuit), intended to control, measure, signal, regulate and process data. Auxiliary circuits of an ASSEMBLY include the control and the auxiliary circuits of the switching devices.

**Busbar** is a low-impedance conductor to which several electric circuits can be separately connected.

**Main busbar** is a busbar to which one or several distribution busbars and/or incoming and outgoing units can be connected.

**Distribution busbar** is a busbar within one section which is connected to a main busbar and from which outgoing units are supplied.

## Commercial Switchboards

This type of switchboard has its framework made up as a pressed steel cubicle. Switches and fused switches identified as 'mini form units', are mounted into slots as required and connected to the internal busbar system by sliding callipers or nuts and bolts. The larger cubicles can be sized to accommodate additional sub-boards or metering equipment. Every electrical installation should have a main switchboard.

To comply with Regulations, it should be fitted with:

- A main switch or switches for control of electricity throughout the installation; and
- Protective fittings rated to protect all circuits of the installation.
- The main switch must be accessible and not mounted higher than 2 metres above the ground or floor.

## Types of Assemblies

Cubicle-type ASSEMBLY is an enclosed ASSEMBLY in principle of the floor-standing type which may comprise several sections, sub-sections, or compartments.

Multi-cubicle-type ASSEMBLY is a combination of many mechanically joined cubicles.

Desk-type ASSEMBLY is an enclosed ASSEMBLY with a horizontal or inclined control panel or a combination of both, which incorporates control, measuring, signalling apparatus.

Box-type ASSEMBLY is an enclosed ASSEMBLY, in principle intended to be mounted on a vertical plane.

Multi-box-type ASSEMBLY is a combination of boxes mechanically joined together, with or without a common supporting frame, the electrical connections passing between two adjacent boxes through openings in the adjoining faces.



*Desk type assembly*



*Multi-cubicle type assembly*

## Switchboards

This section looks at the requirements of switchboards. Switchboards must comply with the relevant requirements of AS/NZS 3439. You should consult AS/NZS 3439 for detailed information and, as always, AS/NZS 3000:2007

### General Construction of Switchboards

Switchboards must be able to withstand the mechanical, electrical and thermal stresses that are likely to occur in service. They should also comply with the following:

- Access to live parts and their arrangement is such that their basic protection is provided by enclosures.
- Minimum clearances and creepage distances in air are maintained by rigidly fixing all bare conductors and bare live parts of a switchboard.
- Orientation of circuit-breakers is such that where two or more circuit-breakers are mounted in the same row, the operating mechanism of each shall cause the circuit to open when the operating means are orientated in one general direction.
- Fuses using screw-in carriers shall be connected so that the centre contact is on the supply side of the fuse base.

## Busbar Arrangements

Fittings associated with the neutral and earth busbars of a switchboard, should be rated to the maximum connected load current, and have their conductors arranged for ease of installation, and removal without disturbance to any other circuit.

The main neutral and earth conductors, and any connecting link should meet the requirements covered in Section 2.9.4 of AS/NZS 3000-2007.

Phase busbars should be installed so that they are accessible for connection of conductors and, have a current rating equal to the maximum demand placed on them, except when they are centre fed in which case the rating can be effectively reduced. It is always a good recommendation to size busbars to accommodate for future expansion particularly in industrial situations.

The identification of busbars for phase, neutral, or earth can be best achieved by using a coloured plastic sleeve that shrinks to the actual size of the bar when heated. This method not only provides for colour code identification, but also provides an insulation barrier reducing the risk of accidental contact with live busbars.

The busbars (bare or insulated) shall be arranged in such a manner, that an internal short circuit is not to be expected under normal operating conditions. They shall be rated to withstand, at least, the short-circuit stresses limited by the protective device(s) on the supply side of the busbars.

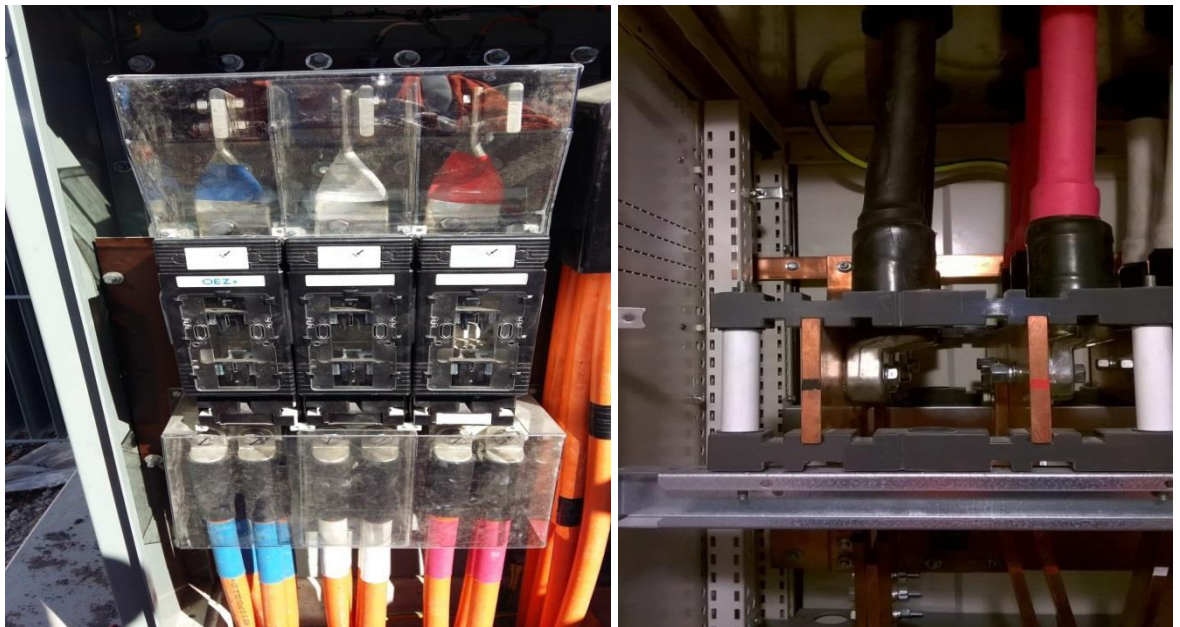

*Busbar assembly with coloured plastic sleeves*

## Control and metering equipment

Revenue meters, CT's and load control devices are supplied by the MEP and remain their property. The MEP is responsible for maintaining metering accuracy and certification.

Metering equipment is installed in a meter box along with associated wiring and load control devices.

Only authorised persons may work on MEP equipment. The Electricity Act and retailers' network terms and conditions prescribe penalties for not adhering to this.

All wiring associated with metering must comply with the wiring rules AS/NZS 3000:2007.

All metering equipment should be readily accessible and protected from damage.

## Markings and Equipment Identification

All equipment installed on a switchboard shall be legibly, and indelibly identified in the English language. The relationship of switches, circuit-breakers, fuses, RCDs, and similar electrical equipment to the various sections of the electrical installation, shall be marked on or adjacent to the switchboard.

Bars and links shall be identified to indicate whether they are active, neutral or earth. The terminals for the connection of the MEN connection and for the main neutral conductor, shall be legibly and indelibly marked at the main neutral bar or link. Where a common neutral is used for two or more different circuits, it shall be legibly and permanently marked to identify the associated active conductors.

Where access to live parts is required, the symbolic electric shock risk sign shall be displayed in locations where additional attention is required to be given to the removal of covers and the like.



In addition, a DANGER sign with an additional message of appropriate wording, should be conspicuously displayed on the enclosure of the ASSEMBLY to alert persons to the hazard. Examples of these can be seen below.

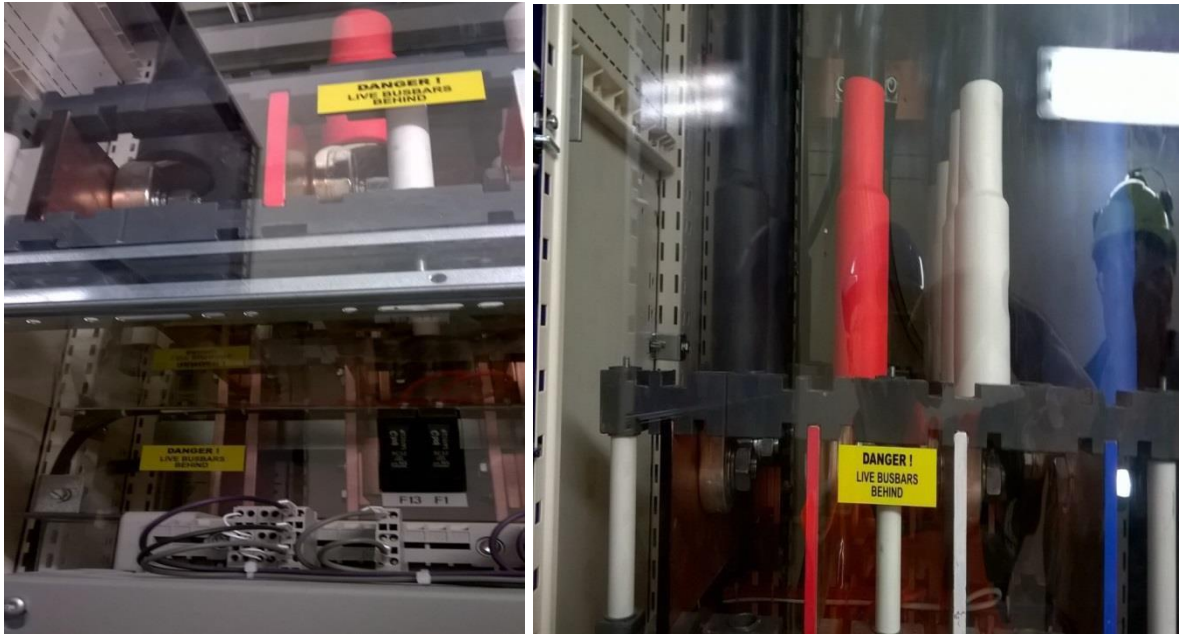

## Wiring

Switchboard wiring shall be designed and installed to withstand any thermal and magnetic effects on the conductors. Where provision is made to hinge or remove switchboard panels, all conductors connected to electrical equipment on the switchboard panel shall be:

- provided with enough free length to allow the panel to be moved into a position to enable work to be carried out; and
- suitably fixed or otherwise retained in position to avoid undue movement or stress at terminals of electrical equipment, when the panel is moved or is fixed in position; and
- arranged to prevent undue pressure on electrical equipment mounted behind the panel.

## Access to Live Parts

Live parts shall be arranged so that basic protection is provided by enclosures. An exception is that live parts may be exposed in a non-domestic electrical installation provided that:

- the live parts are arranged so that basic protection is provided by barriers;
- the switchboard is installed in an area that is accessible only to authorised persons and the means of access to such areas is provided with facilities for locking.

In situations where the removal of covers and the like exposes live parts, such covers shall be identified. This requirement does not apply to domestic switchboards. In addition:

- Switchboards shall be located to allow easy access to fittings.
- Any switches, operating handles, or controls associated with switchboards are to be located not more than 600 mm from the edge or side of the cupboard or bench across which a person must reach to operate, or work on the switchboard.
- Where a switchboard is designed to allow persons to enter the switchboard enclosure, provision shall be made for ready and safe access and exit from such a space.
- Any opening or doorway to a switchboard area shall be not less than 600 mm wide and shall extend from the floor of the switchboard area for a height of not less than 2m.
- Any door which is intended to allow persons to leave the vicinity of the switchboard shall open outwards, away from the switchboard, without the use of a key or tool.

## Maximum Prospective Fault Current Condition

Switchboards must have an appropriate fault rating and protection devices to withstand the maximum prospective short circuit fault current.

The most common nominal fault current ratings, in industrial areas for switchboard design in New Zealand and Australia are, 50kA, 63kA and 80kA for 1 second. Typically, a zero-impedance fault will allow a 1000kVA transformer to provide a fault current of up to 28 kA. You should be aware of what the prospective short circuit current will be under fault conditions and ensure that all the equipment is suitably rated.

## Fire-Protective measures

Wiring associated with switchboards shall be installed in such a manner that, in the event of fire originating at the switchboard, the spread of fire will be kept to a minimum. Where a switchboard is enclosed in a case or surround, any wiring systems entering the switchboard enclosure shall pass through openings that provide a close fit.

Protection against arcing faults currents while the equipment is in service, or is undergoing maintenance, shall be provided for heavy current switchboards. Fault-current limiters that are used to protect fire and smoke control equipment, evacuation equipment, or lifts shall not be used to provide protection to any other part of the electrical installation.

Cables associated with fire and smoke control equipment, evacuation equipment, and lifts shall be capable of maintaining an adequate supply of electricity to the equipment when exposed to fire.

Each part of an electrical installation supplying electricity to fire equipment, shall be controlled by separate main switch from those used to control the remainder of the electrical installation.

Switches operating in the circuit supplying electricity to fire and smoke control equipment, evacuation equipment, or lifts shall be clearly marked to indicate the fire and smoke control equipment, evacuation equipment, or lifts that they control.

Where fire-pump motors are automatically controlled, a manually operated isolating switch shall be connected on the supply side of the pump motor controller. Over-temperature protective fittings shall not be provided on fire-pump motors, where the operation of such fittings might reduce the operating time of the equipment under emergency conditions.

## Preventing Internal Arc Fault

Protection against arcing fault currents while the equipment is in service, or is undergoing maintenance, shall be provided for heavy current switchboards. Heavy current circuits are regarded as those where the nominal supply current to the switchboard is 800 A or more per phase. The supply conductors up to the line side of the protective device(s) within the switchboard, shall be provided with means to reduce the probability of initiation of arcing faults, by insulation or by separation.

Heavy current switchboards shall be provided with internal separation for:

- Busbars from functional units;
- Functional units from one another;
- Terminals provided for external conductors from the busbar;
- A safety service circuit section of the switchboard, if any, from the general installation circuits section.

Barriers for manual switching devices shall be so designed, that the switching arcs do not present a danger to the operator. A barrier is a part providing protection against direct contact from any usual direction of access (minimum IP2X), and against arcs from switching devices and the like. To minimise danger when replacing fuse links, interphase barriers shall be applied, unless the design and location of the fuses makes this unnecessary.

It is desirable that the highest possible degree of protection to personnel, should be provided in case of a fault leading to arcing inside an assembly, although the prime objective should be to avoid such arcs by suitable design, or to limit their duration.

Switching devices and components, shall be installed in accordance with the instructions of their manufacturer (position of use, clearances to be observed for electric arcs or for the removal of the arc chute, etc).

The switching devices and components shall be installed and wired in the assembly in such a manner, that its proper functioning is not impaired by interaction such as heat, arcs, vibrations, fields of energy, which are present in normal operation. In the case of electronic assemblies, this may necessitate the separation or screening of monitoring circuits from power circuits.

Protective devices shall be provided to limit, as far as practicable, the harmful effects of a switchboard internal arcing fault by automatic disconnection.

# Switchboard Location and Accessibility Requirements

## Switchboard Location and Environment

Switchboards shall be installed in suitable, well ventilated places and protected against the effects of moisture to which they may be exposed. They shall be arranged to provide enough space for the initial installation and later replacement of individual items of the control and protective devices. They must be accessible for operation, testing, inspection and maintenance and repair.

## Ventilation

Care must be taken to provide adequate ventilation, where necessary, in order to maintain operating temperatures within the rated or specified limits of the affected equipment, if heat is generated in normal operation.

## Accessibility

The main switchboard shall be readily accessible. The main switchboard, or a panel for the remote control of main switches shall be located within easy access of an entrance to the building.

In multiple electrical installations the main switchboard shall not be located within any tenancy or single electrical installation of a multiple premise, either domestic or nondomestic.

Adequate space shall be provided around a switchboard on all sides where persons are likely to pass. (The intent of this obligation is to enable all fittings to be safely, and, effectively operated and adjusted, and to enable ready escape from the vicinity of the switchboard under emergency conditions.). The space must have a horizontal clearance of not less than one metre from any part of the switchboard or fitting; and a vertical clearance to a height from the ground floor or platform or other walked on surface of 2m, or no more than the height of the switchboard, whichever is the greater.

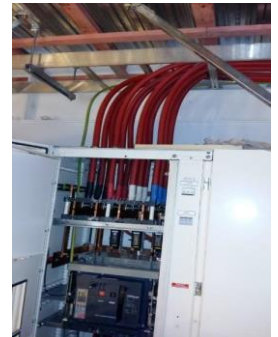

## Restricted locations and General Positioning

A switchboard shall not be put in the following areas:

- Within 1.2m of the ground floor or platform;
- Above open water containers or fixed stationary cooking appliances;
- Within a fire-isolated stairway, passageway or ramp;
- In a cupboard containing a fire-hose reel;
- Within a sauna;
- Within a refrigeration room;
- Within any zone classified for a bath or shower;
- In hazardous areas;
- Within or above any zone classified for a swimming pool or spa pool.

In addition to the above:

- Switchboards installed in classified zones in locations subject to sanitization or hosing down operations shall be provided with a minimum degree of protection of IPX6.
- A switchboard installed in a cupboard or similar enclosure shall only be installed in an area set aside for the purpose.
- Switchboards shall be located or arranged to minimise the impact of any smoke generated from a fault in the switchboard effecting the egress from the building.
- A switchboard may be installed within a cupboard or similar compartment in other forms of required exit or in any corridor, hallway, lobby or the like leading to an exit, provided that the cupboard or compartment doors are sealed against the spread of smoke from the cupboard.
- Main switchboards and safety services switchboards shall not be installed in the vicinity of fire sprinkler systems.

Check out AS/NZS 3000 for more details of restricted locations and positioning

## Identification of the Main Switchboard

The main switchboard shall be legibly and permanently marked 'MAIN SWITCHBOARD'.

Where a main switchboard is located within a room or enclosure, any door required for immediate personal access shall be prominently and permanently marked to identify the room or enclosure in which the main switchboard is located. The location of the main switchboard shall be legibly and permanently indicated by a conspicuous notice at each entry to the building that may be used by emergency services personnel.

Notices indicating the location of the main switchboard shall be of permanent construction and shall incorporate the term 'MAIN SWITCHBOARD' in contrasting colours.

Exceptions are as follows:

- Identification of the main switchboard and its room or enclosure need not apply in a single domestic electrical installation.
- The location of the main switchboard need not be marked at an entry to a building where the location is clearly indicated at a Fire Indicator Panel.
- The location of the main switchboard need not be marked where the location can be readily determined, e.g. where it is clearly visible from the main entrance to the electrical installation.

## Ventilation

Care must be taken to provide adequate ventilation, where necessary, in order to maintain operating temperatures within the rated or specified limits of the affected equipment if heat is generated in normal operation.

## Installation of RCD on Switchboards

The use of fixed setting RCDs with a rated operating residual current not exceeding 30 mA, is recognised as providing additional protection in areas, where excessive earth leakage current, in the event of failure of other measures of protection or carelessness by users, could present a significant risk of electric shock.

RCDs do not provide protection against faults between live conductors, nor do they provide protection against voltages imported into the electrical installation earthing system, through the supply system neutral conductor.

The use of such devices is not recognised as a sole means of protection and does not obviate the need to apply the protective measures. Additional protection shall be provided, to automatically disconnect the supply when an earth leakage current reaches a predetermined value.

The use of a 10 mA RCD may be considered in areas of increased risk, such as circuits supplying outdoor equipment, bathrooms and areas such as kindergartens and patient treatment areas.

Any device for the provision of additional protection, shall be capable of interrupting the part of the circuit protected by the device when an earth leakage current is above a predetermined value.

The load current rating of an RCD shall not be less than the greater, of the maximum demand of the portion of the electrical installation being protected by the device, or the highest current rating of any overload protective device, on the portion of the electrical installation being protected.

No earthing or protective bonding conductor shall pass through the magnetic circuit of an RCD.

RCDs shall be fixed setting complying with AS/NZS3190, AS/NZS61008.1 or AS/NZS61009.1 and intended for use in electrical installations

RCDs can have any number of poles but shall interrupt all active and neutral conductors.

## Arrangement

Where additional protection of final subcircuits is required in accordance with AS/NZS 3000:2.6.3, the final subcircuits shall arranged as follows:

In all electrical installations where the number of RCDs installed exceeds one and more than one lighting circuit is installed, the lighting circuits shall be distributed between RCDs.

In residential installations, not more than three final subcircuits shall be protected by any one RCD and where there is more than one final subcircuit a minimum of two RCDs shall be installed.

These arrangements are intended to minimise the impact of the operation of a single RCD.

# Part 3: Switchboard schematic diagram

## Switchboard Schematic

This switchboard schematic shows a three-phase supply, with a three-phase motor starter using PLC control. There is also a pump circuit and a feed to a distribution board.

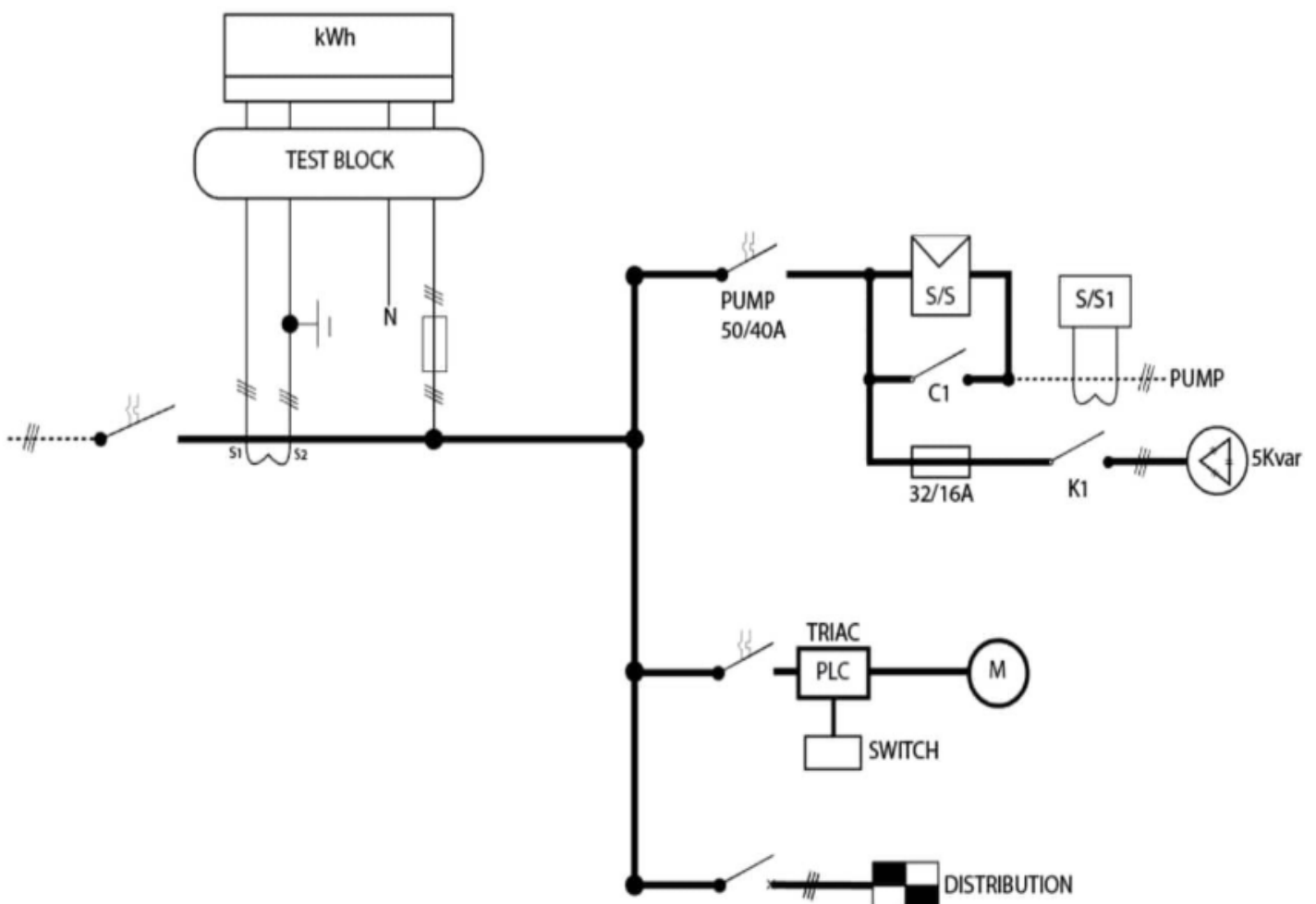

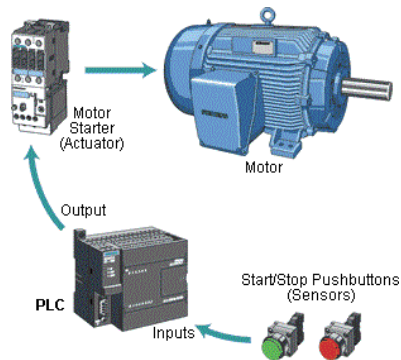

Motor wiring

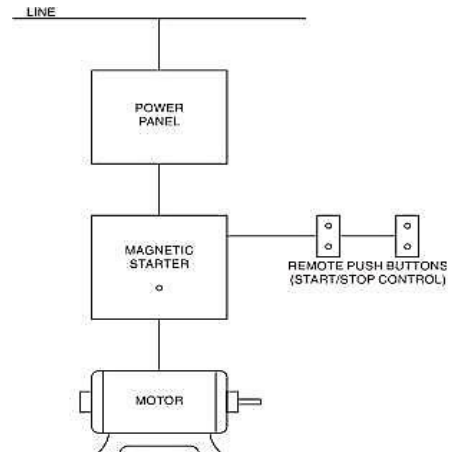

Motor wiring



Cubicle assembly

## Cable Size Calculation

Cable selection procedure is covered in detail in section 2 of AS/NZS 3008.1.2. You must read through and familiarise yourself with this section.

Main factors influencing selection of a cable are:

- Current carrying capacity which is dependent upon the method of installation and the presence of external influences such as thermal insulation, which restrict the operating temperature of the cable;
- Voltage drop which is dependent upon the impedance of the cable, the magnitude of the load current and the load power factor;
- Short circuit temperature limit which is dependent upon energy produced during the short circuit conditions.

Assessment of cable calculations will be covered in a separate assessment.

# Part 4: Potential for electrical interference

**Electromagnetic interference (EMI)**, also called **radio-frequency interference (RFI)** when in the radio frequency spectrum, is a disturbance generated by an external source that affects an electrical circuit by electromagnetic induction, electrostatic coupling, or conduction. The disturbance may degrade the performance of the circuit or even stop it from functioning.

Some sources of EMI found in industry are: Variable frequency drives, soft start motor starters, SCR heater controllers, power and auxiliary contacts, A.C and D.C motors, A.C and D.C generators, switching power supplies, power wiring, which radiates 50 Hz/60 Hz noise, walkie talkies, arc welding, fluorescent bulb ballasts, electrostatic discharge lightning.

As per AS/NZS 3000:4.1.4, all electrical equipment shall be selected so that during normal operation including switching, it will not cause harmful effects to other equipment.

Factors that may need to be considered include the following:

- Power factor
- Excessive voltage fluctuation
- Severe distortion of current waveforms
- Electromagnetic emission

## Means of Preventing Common Sources of Electrical Interference on Low Voltage Signals with Reference to the Minimum Installation Requirements to Eliminate Interference.

Electrical interference on low voltage signals come from several different sources. These include:

- Cable alignment
- Power cables
- Cable proximity
- Radio signals
- Switching devices

In this part, we will look at how electrical interference from each of these sources can be eliminated.

Certain types of electrical installations, for example, those containing sensitive electronic equipment or systems may require minimisation of electromagnetic interference, arising from magnetic fields developed from current flowing in cables.

This may be addressed by:

- Selection of cables designed for low magnetic field emissions or
- Installation of cables in enclosures that contain or shield fields or
- Installation of cables in configurations that produce low magnetic fields.

AS/NZS 3008.1 series details configurations for the installation of parallel single-core cables in groups, that produce reduced levels of magnetic fields in comparison with other electrically symmetrical installations.

## Cable Alignment

Electrical noise, also known as electromagnetic interference, can destroy a clean signal from measurement instrumentation (such as level sensors and pressure transducers). Protecting sensors from electrical noise is a top priority. Luckily, this is a relatively simple task in most cases.

Cable alignment falls into four distinct steps to keep electromagnetic interference (EMI) at bay. You need to use properly shielded cable, you must be careful when routing cables, and sensors need to be grounded properly. Finally, it's important that the signal output is appropriate for the electrical environment.

## Shielded Cable

Using shielded cable may seem like a no-brainer. However, it is often overlooked when budgets are tight, or when the risks are not understood. Good wire for instrumentation is usually twisted and shielded – though the specific cable varies depending on the sensor. Make sure to stick to the manufacturer's recommendations.

## Cable Routing

Routing the cable properly is very important. Unfortunately, this is often forgotten.

The image shows a signal cable routed right next to an electrical outlet. This is wrong! Signal cable should be routed away from electrical cable, power sources, electric motors, and any other electrical fixture. Higher voltages increase electrical noise. Electric motors are especially bad, as they produce a magnetic field.

How far away do you need to route the cable? That depends on things like voltage and the size of any magnetic fields. However, even a few inches can make a huge difference. Do the best you can to keep them separate. If you notice a noisy signal, then you need to do a better job.



## Earthing

Sensors should be connected to a good earth. Avoid earth loops by using a single earth, or by ensuring that multiple earths have the same potential. Earth is the path that carries electrical noise away from your signal wires.

The shield in the cable should have a good contact with a drain wire, which should be connected to earth. This provides a path for electrical noise to travel to earth, instead of using the signal wire. If the connection to earth is insufficient, the shield will be ineffective. If an earth loop exists, a current will flow through the cable shield and will not stop EMI.

An improper earth is bad. Not only will the sensor be prone to EMI, but you'll also lose your protection from power surges. In addition, an electrical circuit without an earth increases the risk of shock. Proper earthing should be a top priority.

By contrast, a good earth, proper cable routing, and the right signal cable will stop electromagnetic interference – keeping measurement signals clean.

## Cable Resistance

Cable resistance should be kept to an absolute minimum for signal wires. This means that care must be taken with:

- Cross sectional area,
- Length of run, and
- Joints.

## Power Cables

Since power is dissipated by electromagnetic effects like eddy currents, regulations provide for methods of limiting these effects.

## Cable Alignment of Power Cables

- Single core cables armoured or with steel wire or tape shall not be used for a.c circuits.
- Conductors of a.c circuits installed in ferromagnetic enclosures shall be arranged so that the conductors of all phases and the neutral conductor (if any) and the appropriate protective earthing conductor of each circuit are contained in the same enclosure.

Where such conductors enter a ferrous enclosure, they shall be:

- arranged so that the conductors are not individually surrounded by a ferrous material, or
- provided with other means of limiting any excessive heating effects of eddy (induced) currents.

Care must be taken where single-core cables carrying current in excess of 300A pass through ferrous metal wall lining, switchboard surrounds or similar ferrous enclosures.

The use of non-ferrous enclosures or gland plates or where suitable, providing an air gap by slotting between individual core entries to break the magnetic circuit, may be applied to eliminate this effect. A slot between individual core entries with a width of 20% of the individual core entries diameter is considered satisfactory.

## Cables with Non-Ferrous Metal Sheathing

Single-core cables enclosed in lead, copper, aluminium or other non-ferrous metal sheathing may be used for alternating currents only where one of the following arrangements is employed:

- The cables shall be run in trefoil formation throughout their entire length.
- The sheaths of the cables shall be bonded at the point where the trefoil formation ceases or at the switchboard termination and the bonding conductor conductivity shall be not less than that of the cable sheath.

Other than in trefoil formation

- The cables shall be placed near as practicable to each other (touching).
- The sheathing of the cables shall be bonded at both ends and at intervals not exceeding 30 m along the cable run. The bonding conductor conductivity shall be not less than that of the cable sheath.

**Exception:** where the sheathing of cables is provided with an overall continuous covering of insulating material (serving), the bonding need only be carried out at both ends.

# Cable Proximity

## The Proximity Effect

When cables are positioned side by side, the currents flowing in opposite directions repel each other because of the associated magnetic fields.

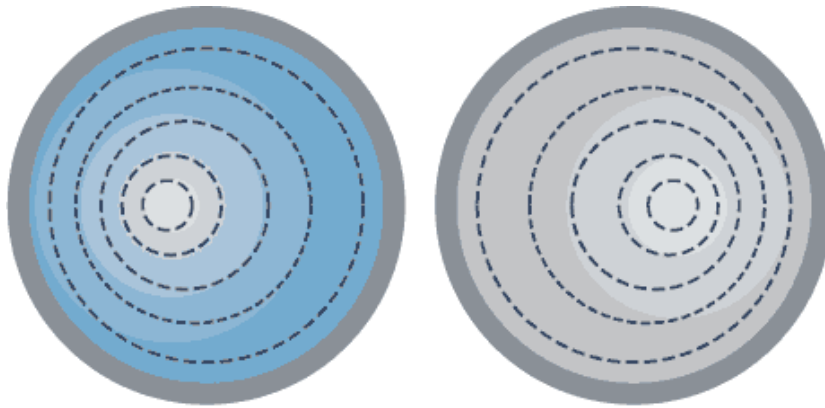

### **The Proximity Effect**

The currents in the two conductors are flowing in opposite directions

The current flow therefore becomes non-uniform across the cross-section of each conductor. This increases the conductor's resistance. An alternative and more effective method of cable construction consists of twisting the two conductors together so that they are not parallel to each other, and therefore do not suffer from the proximity effect.

This is a result of reactance, and in terms of AS/NZS 3000, reactance may generally be ignored for conductors of 35 mm<sup>2</sup> or less, where the active and earthing conductors are in the proximity to one another.

## General

The following conditions must be satisfied when installing electrical services:

- Wiring systems may not be installed in the vicinity of services that produce heat, smoke or fumes likely to be detrimental to the wiring system, except where wiring systems may be installed in so that the wiring system is protected from harmful effects, by shielding that does not affect the dissipation of heat from the wiring system.
- Where a wiring system is situated below services liable to cause condensation (such as water, steam or gas services), precautions shall be taken to protect the wiring system from harmful effects.
- Where electrical services are installed close to non-electrical services, they shall be so arranged that any reasonably foreseeable routine operation carried out on the other services will not cause damage to the electrical services.
- Wiring systems shall be suitably protected against the hazards likely to arise from the presence of other services in normal use.
- Cables without sheathing or further enclosure, shall not be installed in enclosures where they are accessible to personal contact, or where they may contact other services, such as water, gas, hydraulic or communications systems.

## Radio Signals

Radio suppression devices require a separate earthing arrangement, where a clean earth is required for data or signalling purposes in certain items of electrical equipment, the manufacturer of the electrical equipment should be consulted in order to confirm the necessary arrangement.

Where required for operational purposes, functional earth connections for data and signalling purposes should be insulated from all protective earthing connections and conductors and should only be connected at one point, normally at the connection to the main earthing terminal/connection or bar. Avoid unintentional contact between the two earthing systems.

## Fast Switching Power Electronic Devices

Power electronic converters are widely used in many applications including renewable energy generation, industrial equipment variable frequency drives, and household appliances. Power converters like electronic ballasts, computer power supplies for telecommunications equipment, UPS, and battery chargers use fast switching power semi-conductor switches such as MOSFET and IGBT as the preferred switching devices. These switching devices have the potential to cause EMI due to the high switching rates.

To mitigate the effect of this EMI, RC or LC filters can be installed to reduce the emission from power converters. RF EMI/RFI filters are connected on the input side of variable speed drives or inverter.

- Use shielded wiring where possible;
- Physically separate the filter input and output conductors;
- Use single point grounding;
- Connect the incoming power conductors to the “Line” side terminals of the filter;
- Connect the “Load” side terminals to the line reactor or drive input terminals;
- Keep all wiring as close as possible to the grounded panel (ground plane).

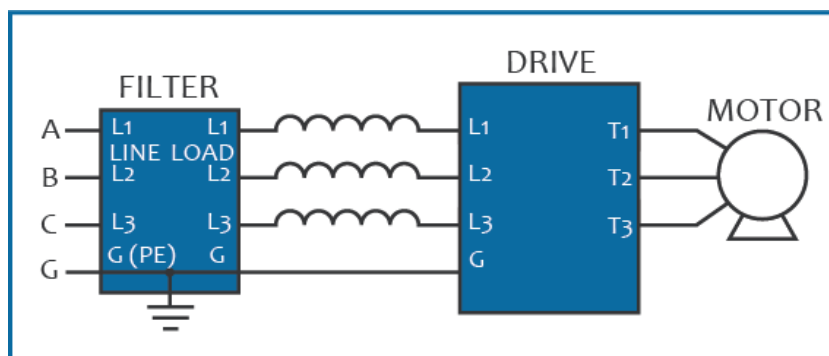

*RFI filter*

## How to Reduce the Effects of EMI

Here are some tips for reducing the effects of EMI:

- Always run power wiring and instrument signal wiring in separate conduits or separate cable trays. Maintain this separation as much as practical in the control panel.
- If instrument wiring must cross over power wiring, cross at a 90° angle while maintaining as much separation as possible.
- Avoid forming loops in instrument wiring – the wire should run as straight as possible.
- Use twisted pair shielded cable to carry instrumentation signals. Twisting the wires equalises the effect of EMI on both wires, greatly reducing error due to EMI. Surrounding the instrument wires with a shield protects them from EMI and provides a path for EMI-generated current to flow into ground.
- Connect one end of the shield to ground, preferably the ground point that has the least electrical noise.
- A current signal is inherently more immune to EMI than voltage signal, so it is beneficial to use an isolated transmitter to convert signals into industry standard 4-20 mA current.

This provides the following advantages:

- 4-20 mA signals are highly immune to electrical noise.
  - Unlike voltage signals, 4-20 mA signals will not attenuate over a long distance, (within limits).
  - Most transmitters can be programmed to regulate loop current to an unusually high or low level if the sensor fails. Typically, these limits are 3.5 and 23 mA. In this way, a 4-20 mA signal can notify the system of a sensor error.
  - A broken cable wire will result in 0 mA current flow, which makes it easy to detect a cable error. If voltage signals are used, the high impedance of the downstream instrument makes the broken wiring act like an antenna. EMI can easily induce a voltage onto the wires, making cable break detection unreliable when voltage signals are used.
  - Isolating the measurement protects downstream equipment from damage due to high common mode voltage and eliminates error due to ground loops.
  - Isolating the measured signal will block EMI that is common to both input wires.
  - Most transmitters have adjustable output dampening, which allows you to filter out signal instability caused by EMI.
- 
- In the control panel, minimise the length of unshielded instrumentation wires. Make sure the exposed wires remain tightly twisted all the way to their connection points.
  - In the control panel, route instrumentation cables away from sources of EMI in the panel.
  - Thermocouple and RTD signals are especially prone to error caused by EMI, so be careful where these cables are routed in the panel.

# Part 5: Consumer metering

In New Zealand the electricity supply industry is made up of four parts

- a) **Generators** who make the electricity, from water, gas, wind, coal, geo-thermal activity.
- b) **Networks** who own the infrastructure that connects the generators to the consumers Installation Control Point, via power poles, power lines, and underground services.
- c) **Retailers** who purchase electricity from the generators and sell it to consumers.
- d) **Metering Equipment Providers (MEP)** who supply and lease metering equipment to the retailer.

## Purpose of Metering Equipment

Metering equipment or energy meter is a device, that measures the amount of electric energy consumed by a residence, a business, or an electrically powered device at the installation control point (ICP). The retailer will bill the consumer for the electricity they have used.

Metering equipment is installed in an enclosure (meter box) along with associated wiring and load control devices.

The revenue meter, CT's and load control devices are supplied by the MEP and remain their property.

The MEP is responsible for maintaining metering accuracy and certification.

Interfering or tampering with seals or inserting conductors into any item of metering equipment is not allowed. Only authorised persons are permitted to work on the MEP equipment. The Electricity Act and Retailers/ Network terms and conditions prescribe penalties for such behaviour.

All wiring associated with metering shall comply with the wiring rules AS/NZS 3000. All metering equipment should be readily accessible and protected from damage.

## Types of Metering Installations – Low Voltage

Whole current metering is the most common electricity supply for domestic and small commercial installations, where the supply is either 1 phase or 3 phase, requiring a capacity of up to 100 A per phase.

Typical single-phase metering:

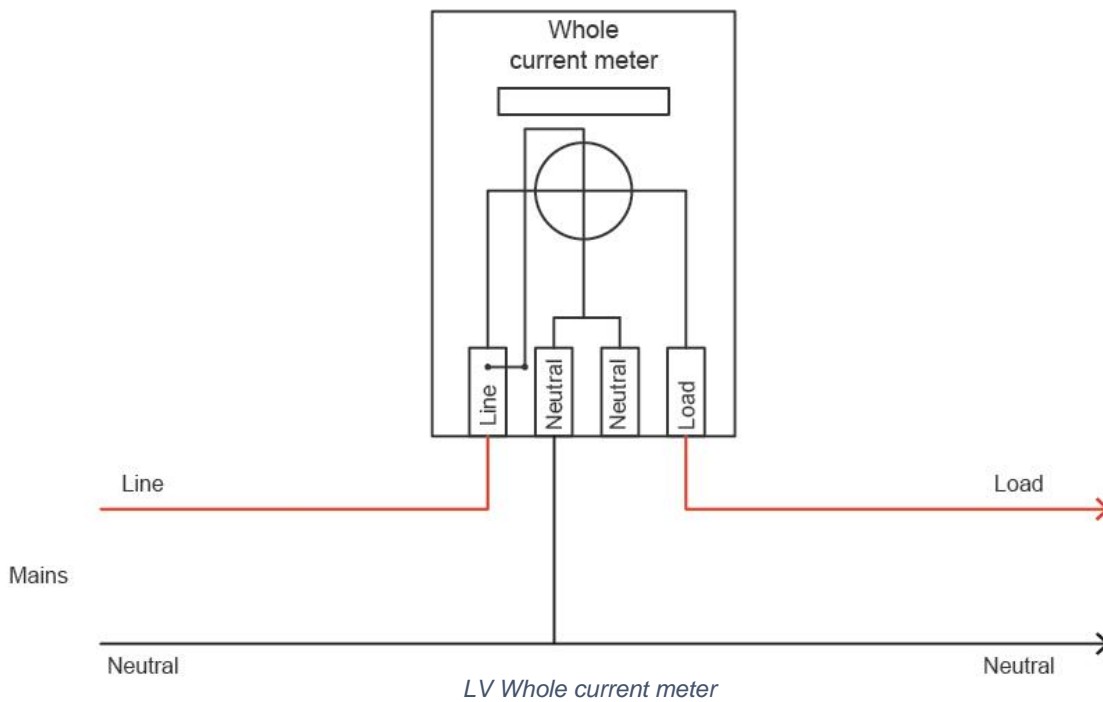

LV whole current meters are connected in line with the customers load circuits, thereby measuring the whole current flowing through the circuits, and recording it through the kWh meters measuring elements.

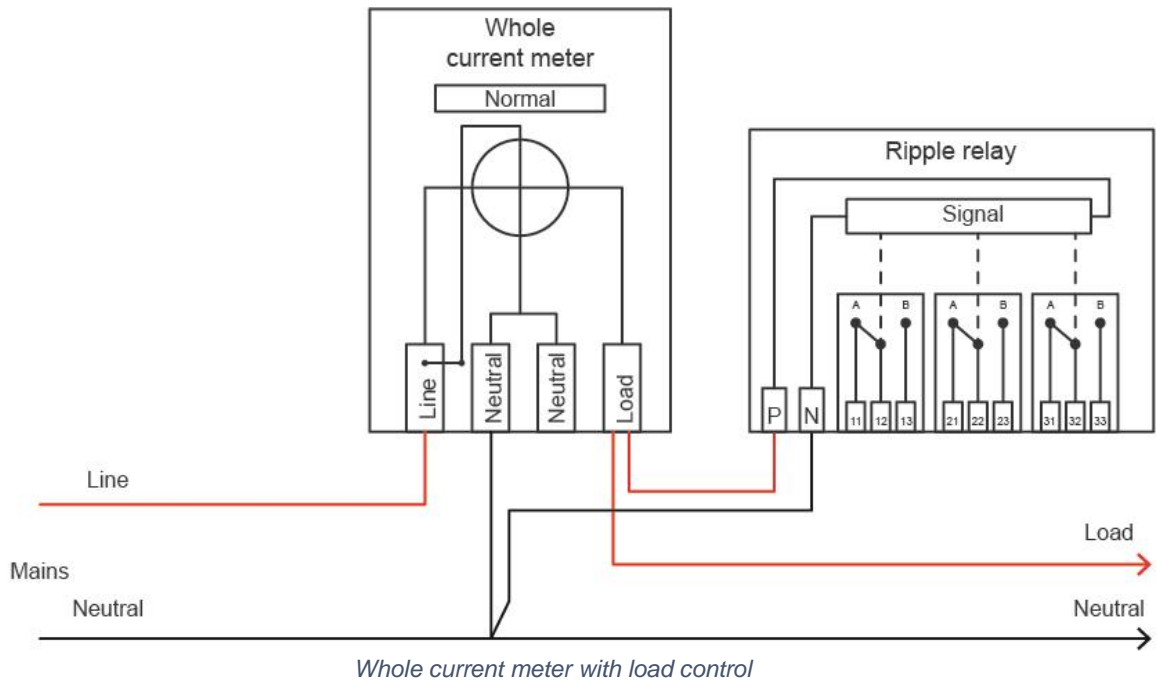

Load control or Ripple relay circuits can be considered in various configurations:

Typical configuration will be when the hot water supply is routed through the Ripple relay; this allows the Network Company to control Peak loads.

There are variations of metering installations which allow for Off Peak / Night rates which are controlled via Ripple relays. These rates are recorded on a second register of the meter or a second meter is installed to record the Night rate consumption.

# Typical Three Phase Whole Current Metering

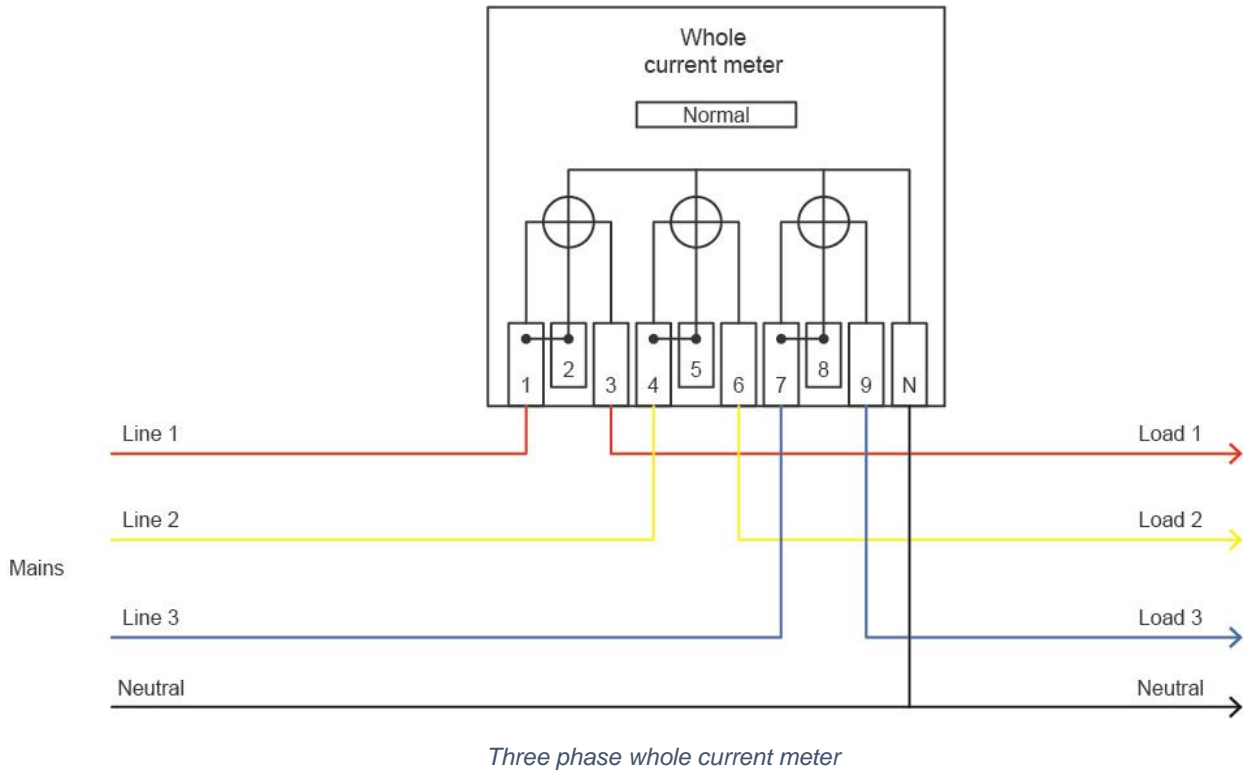

# Typical Whole Current Metering with Load Control

Configuration could vary according to customer agreement and pricing plan.

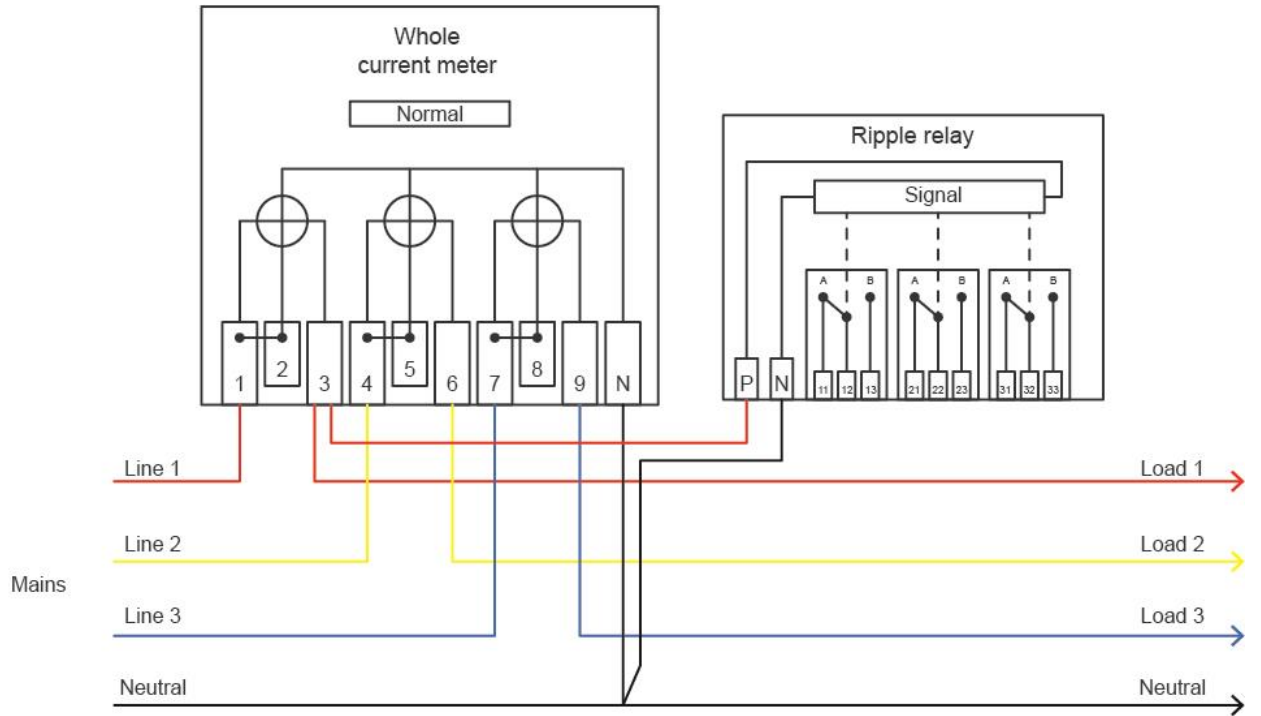

Three phase whole current meter with load control

# Typical Metering Neutral Connection Arrangements

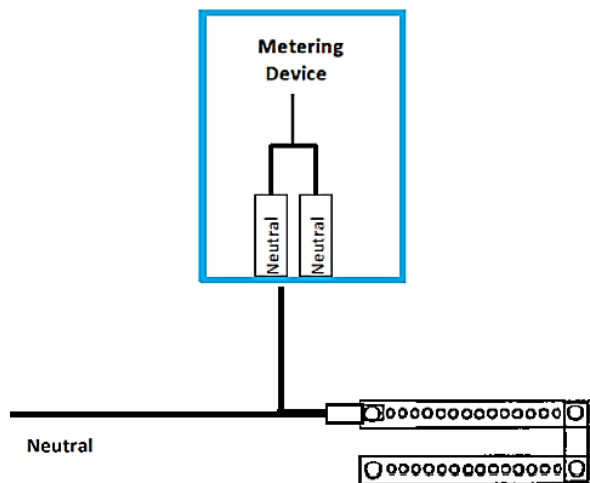
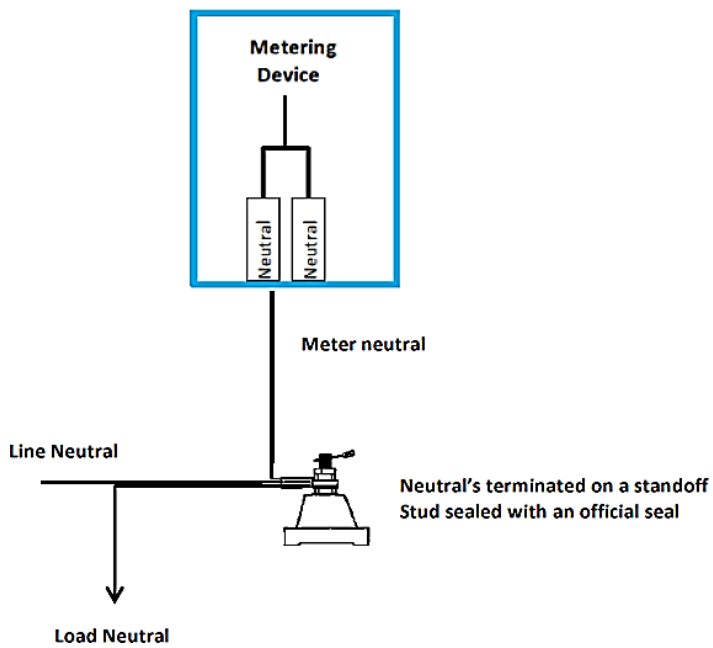
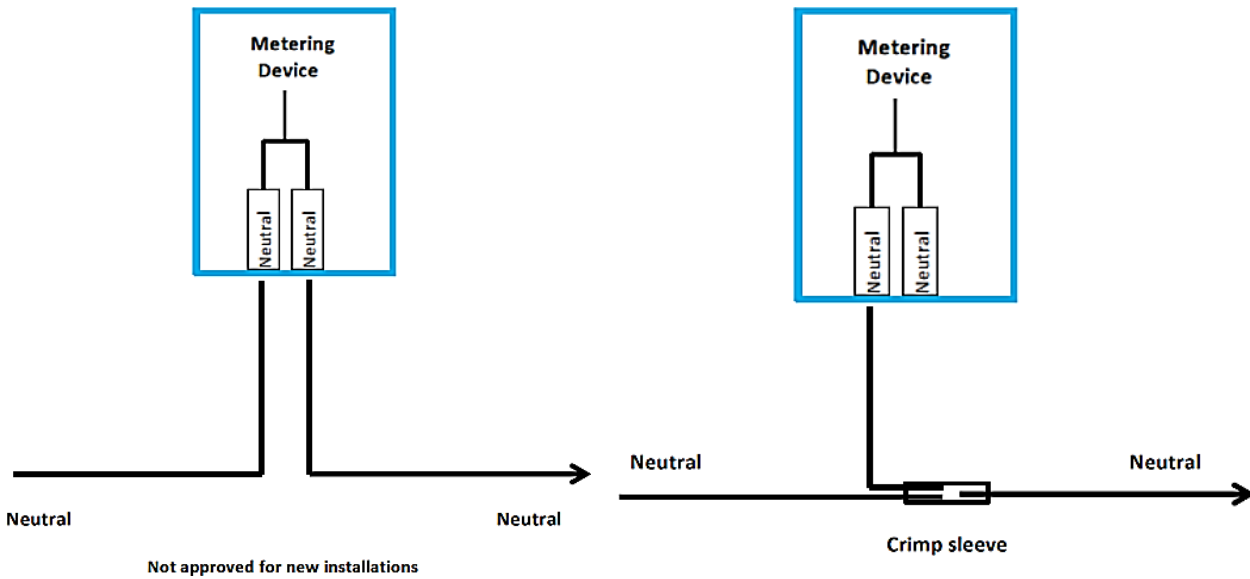

**Options**

- 1) Meter Neutral in same crimp lug as Main Neutral
- 2) If meter neutral is in a separate lug on the same stud , then the stud must be drilled and sealed

## LV CT Metering

When an installations current requirement exceeds 100A, then the installation will be metered using CT metering. CT metering is commonly used for large commercial installations.

Where installations exceed 500A then, 30minute interval data metering is applied. Interval data metering provides detailed consumption data. Retailers have a variety pricing plans to cover interval data customer (Half-Hourly HH). Energy is measured and billed in ½ hour intervals. HH metering will also include equipment that allows the meter to be read remotely.

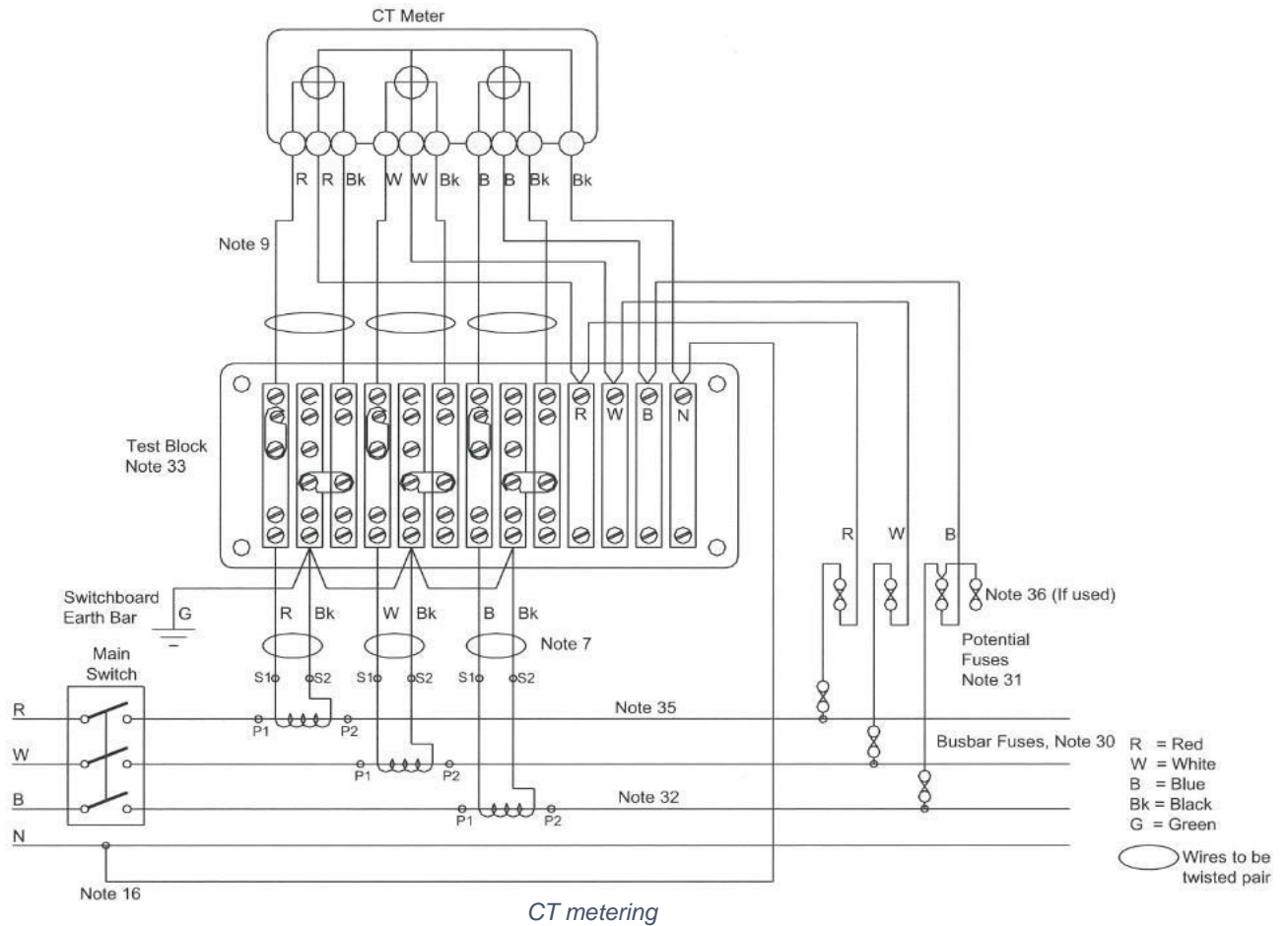

*CTs and metering*

## High voltage metering

When a customer takes supply at HV, the metering will be carried out using CT's and voltage transformers VT's. HV metering is commonly used for very large commercial installations. It is designed by consulting engineers and approved by Class A Test House.

HV metering requires a meter configured ½ hour (HH) metering (interval data metering).

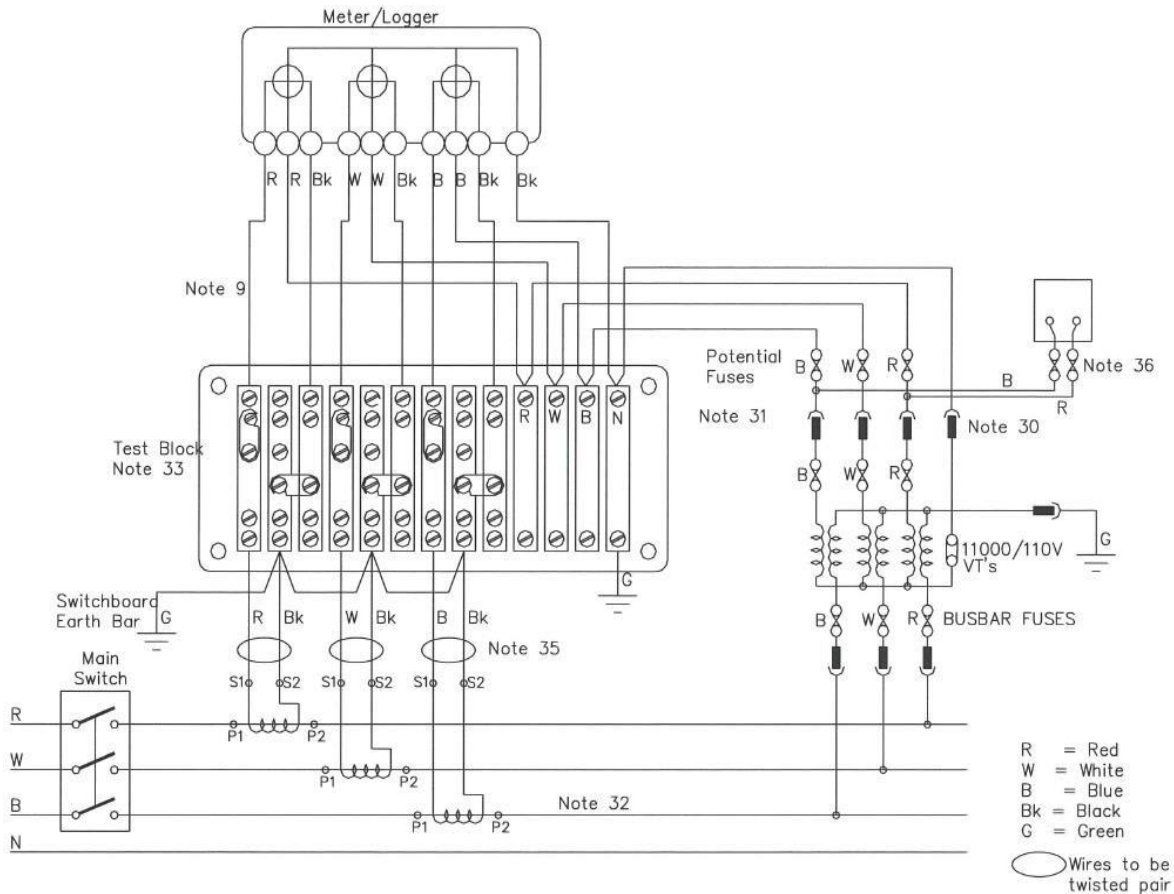

## Distributed Generation and Import / Export Metering

Import/export metering is required if the electricity consumer is also an electricity generator, where electricity flow is possible in either direction at their installation. This type of installation can export to the network as well as import. Typical installation will be a solar installation, or where the customer has a standby generator which can synchronise onto the network and be used by the network owner for Peak lopping.

Meter wiring typically remains standard; however, a suitably configured import/export meter is required.

Sites with distributed generation require approval from the Network Company before generation can be connected, in conjunction with the retailer and MEP.

## Load Control Devices

Ripple relays and contactors are installed to control overload conditions on the network. During peak demand times the network company will control the load by load shedding, this entails injecting a frequency onto the supply mains which will operate the ripple relays which in turn disconnect the supply to controlled loads, such as hot water cylinders.

## Energy Meter Types

There are two basic types of energy meters:

**Electromechanical type:** This operates on the induction disc principle. This type of metering is being replaced by electronic instruments which use digital technology and incorporate microprocessors, which allow them to have more functions and controls than conventional meters.

**Smart meters:** These are new meters which have inbuilt modems, which allow for remote communication. This allows for the meter readings to be sent to a central data collection centre for billing.

Smart meters have an internal or external antenna to achieve the necessary communication.

## Location of Metering Equipment

The following are considered unsuitable mounting locations:

- Where metering equipment is subjected to strong magnetic field.
- Stairways, narrow passageways, ramps, confined spaces.
- Driveways, vehicle access ways, factory passageways or where the person working on equipment would not be effectively protected.
- Positioned nearby to machinery or open type switchgear.
- Atmospheres affected by fumes, dust and humidity.
- Hazardous locations.
- Excessive ambient temperatures exceeding 45°C.

## Location on Domestic Premises

The preferred location on domestic premises is on the front or side of the building within 2 metres of the front or corner. The position should not be likely to become inaccessible due to alterations or fencing installation.

## Location on Commercial Premises

Preferred locations in a multi-tenant or public installation are:

- Common area for meters and fuses.
- Meter switch room where all tenant metering is located.

The location must allow unhindered access to the metering equipment to allow a for servicing and meter reading. The metering equipment must be accessible during business hours without use of keys.

# Meter Enclosures

## Residential Meter Enclosures

Typical dimensions for residential meter enclosures are 600mm high x 400mm wide x 190mm deep.

The enclosure is IP 56 with lid closed.

The panel must be able to open a full 90° with enough space around the enclosure to allow work to be carried out.

You should always confirm metering enclosure requirements in your local area.

## Commercial Meter Enclosures

For whole current metering, the enclosure must have a minimum dimension of 600mm x 600mm x 250mm.

The enclosure is IP 56 with lid closed.

Panel must be able to open a full 90 ° with enough space around the enclosure to allow work to be carried out.

You should always confirm minimum requirements in your local area.

For metering requiring CT's, the enclosure must have a minimum dimension of 600mm high x 900mm wide x 250mm deep with IP 56 rating.

The meter box must be mounted in accordance with AS/NZS 3000.

## Metering Alterations

Increasing the connection capacity or alterations to a building could require that the metering needs to be relocated or upgraded from 1 phase to 3 phases.

The new maximum demand requirements need to be applied for through your retailer, and the local network company.

## Demolishing an ICP

When an electrical supply is no longer required, then the ICP number is demolished and deactivated on the Electricity Authority Register. This is arranged through the retailer. The registry is a national database that contains information on every point of connection on local and embedded networks to which a consumer or embedded generator is connected.





**Te Pūkenga**

[earnlearn-tepukenga.ac.nz](https://earnlearn-tepukenga.ac.nz)

0800 327 648 (0800 EARN IT)