



Theory Preparation Book

Model Answers

INDEX

Contents	Page
Basic Electrical Principles	3
Electrical Safety and Safe Working Practices	15
New Zealand Supply Systems	20
Protective Devices	28
Selection of Cables	50
Switchboards and Isolation Devices	58
Testing, Inspection and Certification	63
Transformers	70
Electric Motor Applications	85
Motor Calculations	100
Alternators	111
Lighting	113
Semiconductor Devices	120
Appendix: Formulae	131

Possible Questions**Question 1**

Describe 5 effects of electrical current.

- (a) Heat;
- (b) Chemical;
- (c) Magnetic;
- (d) Mechanical;
- (e) Physiological;

Question 2

- (a) Sketch the circuit diagram of a single phase circuit, protected by a fuse, controlled by a double pole switch and supplying three resistors connected in parallel. Include an ammeter to measure the total circuit current and a voltmeter to measure the voltage across the resistors.

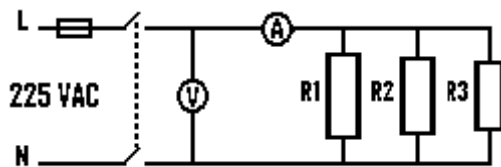

- (b) If each resistor is 150 ohms and the voltmeter shows 225 volts, what is:

- (i) the reading on the ammeter?

$$I_1 = \frac{V}{R} = \frac{225}{150} = 1.5 \text{ A} ; I_2 = \frac{V}{R} = \frac{225}{150} = 1.5 \text{ A} ; I_3 = \frac{V}{R} = \frac{225}{150} = 1.5 \text{ A}$$

$$I_{TOTAL} = I_1 + I_2 + I_3 = 1.5 + 1.5 + 1.5 = \underline{4.5 \text{ Amp}}$$

- (ii) the total power-dissipated by the resistors?

$$\frac{1}{R_T} = \frac{1}{R_1} + \frac{1}{R_2} + \frac{1}{R_3} = \frac{1}{150} + \frac{1}{150} + \frac{1}{150} = \frac{3}{150}$$

$$R_T = \frac{150}{3} = 50 \text{ ohms}$$

$$P = \frac{V^2}{R} = \frac{225^2}{50} = \underline{1012.5 \text{ Watts}}$$

or

$$P = V \times I = \underline{1012.5 \text{ Watts}}$$

Question 3

- (a) Draw a circuit diagram using all of the following electrical components connected to a 230V a.c. supply:
- (i) Two load resistors, one of 23 ohms and the other of 46 ohms.
 - (ii) A two-position selector switch to connect the supply to either of the load resistors.
 - (iii) A voltmeter to measure the voltage across the load.
 - (iv) An ammeter measuring the total current flowing in the load.
 - (v) A fuse.

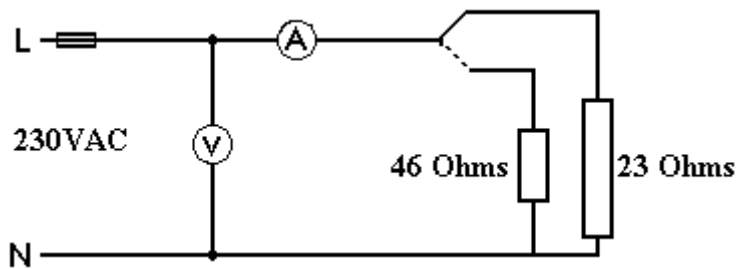

- (b) Calculate the current flow in the circuit when this selector switch connects the supply to the 46 ohm resistor.

$$V = I \times R$$

$$I = \frac{V}{R} = \frac{230}{46} = \underline{5 \text{ Amps}}$$

Question 4

A 230-Volt electrical circuit contains two heating elements, each having a resistance of 46 ohms.

(a) If the two elements are connected in series to the 230 Volt supply what will be the value of:

(i) the current drawn from the supply

$$I_T = \frac{V_T}{R_T} \quad R_T = 46 + 46 = 92 \Omega$$

$$I_T = \frac{230}{92} = \underline{2.5 \text{ A}}$$

(ii) the total power dissipated by the elements

$$W = V \times I = 230 \times 2.5 = \underline{575 \text{ Watts}}$$

(b) If the two elements are connected in parallel to the 230 Volt supply what will be the value of:

(i) the circuit resistance

$$\frac{1}{R_T} = \frac{1}{46} + \frac{1}{46}$$

$$R_T = \underline{23 \Omega}$$

(ii) the current drawn from the supply

$$I = \frac{V_T}{R_T} = \frac{230}{23} = \underline{10 \text{ A}}$$

(iii) the total power dissipated by the elements

$$W = V \times I = 230 \times 10 = \underline{2300 \text{ W}}$$

Question 5

A 240V household radiator has a resistance of 23 Ω and was switched on for 2 hours. Calculate the cost of using the radiator if the tariff is 13c/kWh.

$$P = \frac{V^2}{R} = \frac{240^2}{23} = \underline{2504 \text{ W}} \quad \text{Cost} = 5 \text{ kWh} \times 13\text{c}$$

$$\text{kWh} = \text{kW} \times \text{hours} \quad = \underline{65 \text{ cents}}$$

$$= \frac{2504}{1000} \times 2 = \underline{5 \text{ kWh}}$$

THEORY

Question 6

A private residence consumes 1123 kWh of energy plus 803 kWh for a hot-water heater on an off-peak basis. Calculate the amount of the electricity bill, given the following tariff scale:

- off peak: all units 5.53c/kWh
- general domestic: all units 14.66c/kWh
- general service charge: \$26.36.

Cost:	water heater	803	×	5.53	=	44.41
	general	1123	×	14.66	=	164.63
	service charge					<u>6.36</u>
Total						<u>\$235.40</u>

Question 7

If electrical energy costs 12 c/kWh, for how many hours could a 100 W lamp be used for 60c ?

$$\begin{aligned} \text{If 12c buys 1 kWh, then 60c buys } & \frac{60}{12} \\ & = 5 \text{ kWh} \\ & = \underline{5000 \text{ Wh}} \end{aligned}$$

$$\text{Energy} = \text{power} \times \text{time}$$

$$\begin{aligned} \text{time} &= \frac{\text{energy}}{\text{power}} \\ &= \frac{5000}{100} \\ &= \underline{50 \text{ hours}} \end{aligned}$$

Question 8

Briefly outline the generation of a voltage by a rotating loop in a fixed field.

If a loop of wire is placed so that it can be rotated in a uniform magnetic field an e.m.f. is induced in the loop. If sliding contacts are used to connect the loop to an external circuit a current will flow round the external circuit and loop. The e.m.f. that is generated in the loop depends upon the position of the loop in relation to the magnetic field.

Question 9

With reference to a sine wave, what is meant by the terms cycle, frequency and periodic time.

Cycle: A Cycle is when an a.c. voltage or current passes through a complete set of positive and negative values.

Frequency: The frequency of an e.m.f. is the number of complete cycles that occur in a given time. It is usual to measure frequency in cycles per second.

Periodic time: The time it takes to complete one cycle of a.c.

Question 10

Compare the relationships between voltage and current if a.c. is applied to a pure resistive, pure inductive or pure capacitive circuit.

With alternating current, the current might not be in phase with the voltage. For resistive circuits, both are in phase. For purely inductive circuits the current lags the voltage by 90° . For purely capacitive circuits the current leads the voltage by 90° .

Question 11

Explain the differences between true power, apparent power and reactive power.

Power dissipated by a load is referred to as true power. True power is symbolized by the letter P and is measured in the unit of Watts (W).

Power merely absorbed and returned in load due to its reactive properties is referred to as reactive power. Reactive power is symbolized by the letter Q and is measured in the unit of Volt-Amps-Reactive (VAR).

Total power in an AC circuit, both dissipated and absorbed is referred to as apparent power. Apparent power is symbolized by the letter S and is measured in the unit of Volt-Amps (VA).

These three types of power are trigonometrically related to one another. In a right angle triangle, P = adjacent length, Q = opposite length, and S = hypotenuse length. The opposite angle is equal to the circuits impedance (Z) phase angle.

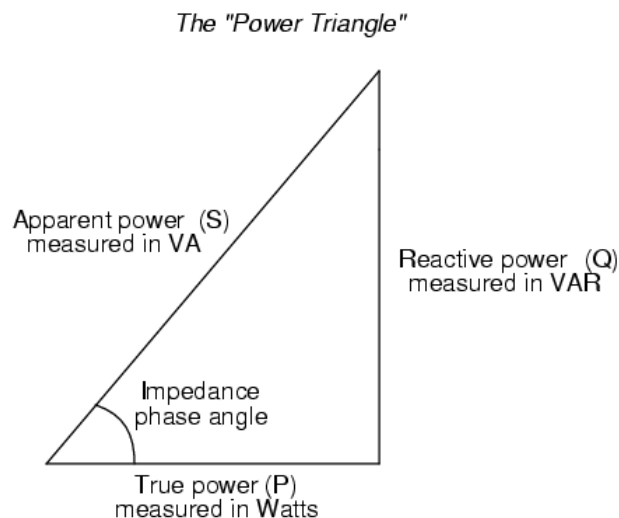

Question 12

What is power factor ?

Power factor is the ratio or factor by which apparent power is multiplied by to obtain the true power being consumed. The value of the power factor depends on the phase difference between the applied voltage and the line current.

Question 13

What are the effects of poor power factor on a distribution system ?

- 1. larger cross-sectional area conductors required.**
- 2. larger transformers.**
- 3. higher rated switch gear.**
- 4. fuses of a higher current rating.**
- 5. higher voltage drops along conductors.**
- 6. extra copper losses.**
- 7. decreased alternator efficiency-higher losses, more fuel.**
- 8. higher generating and capital costs.**

Question 14

Explain how a poor power factor can be improved.

To improve the power factor it is necessary to reduce the phase angle between the line current and voltage, without affecting the values of voltage or load current. Most low power factor problems are caused by inductive loads, such as induction motors and transformers. One method used to improve the power factor in this type of circuit is to connect a capacitor in parallel with the load.

Question 15

Explain with the aid of a diagram how power factor can be measured.

The power factor of a circuit can be measured by using a voltmeter, ammeter and wattmeter. The power factor can then be found from:

$$\text{Power factor} = \frac{P}{S} = \frac{\text{watts}}{\text{volt - amperes}}$$

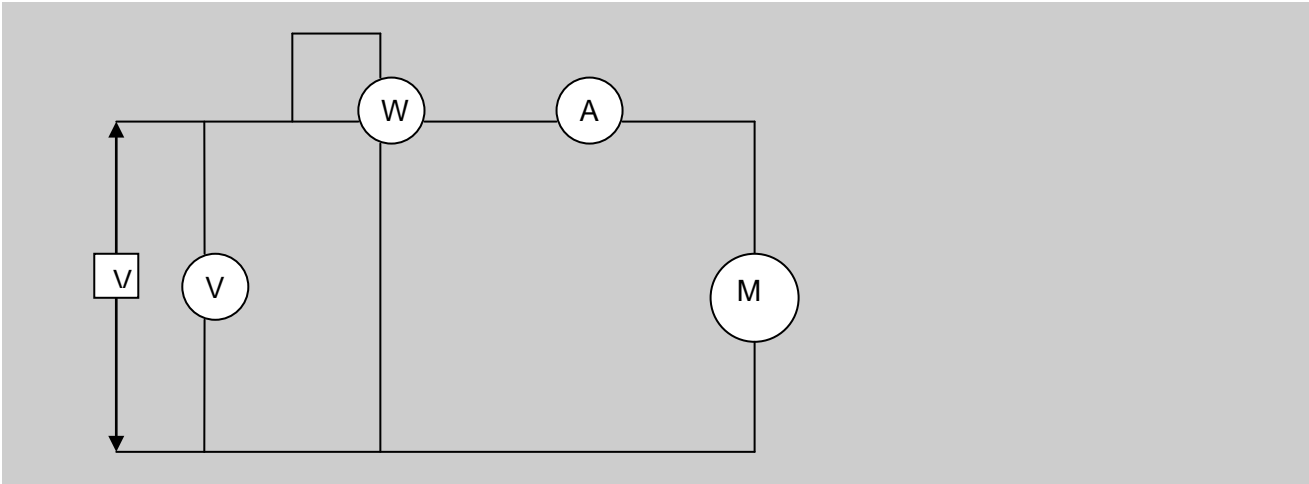
**Question 16**

How does placing a capacitor in parallel to the load improve the power factor?

A pure capacitor is a load that operates at a leading power factor and when connected across an inductive load, tends to oppose the lagging effect of the inductance without consuming any power.

Question 17

A three phase, star connected alternator supplies a delta connected induction motor at a line voltage of 600 V. The current in each line is 40 A. Find:

- the phase voltage of the alternator
- the current in each phase of the motor.

Alternator (star connected)

$$V_L = \sqrt{3} V_{ph}$$

$$V_{ph} = \frac{V_L}{\sqrt{3}} = \frac{600}{\sqrt{3}} = \underline{346.41 \text{ V}}$$

Phase voltage of alternator = 346.41 V

Motor (delta connected)

$$I_L = \sqrt{3} I_{ph}$$

$$I_{ph} = \frac{I_L}{\sqrt{3}} = \frac{40}{\sqrt{3}} = \underline{23.09 \text{ A}}$$

Current in each phase of motor = 23.09 A

Question 18

Three resistors, each having a resistance of 25Ω , are connected to a 415 V , three phase supply. Determine the voltage across each resistor and the current through each resistor when they are connected:

- (a) in star configuration
(b) in delta configuration.

Star configuration

$$V_L = \sqrt{3} V_{ph}$$

$$V_{ph} = \frac{V_L}{\sqrt{3}} = \frac{415}{\sqrt{3}} = \underline{239.6 \text{ V}}$$

Voltage across each resistor = 239.6 V

$$I_{ph} = \frac{V_{ph}}{R_{ph}} = \frac{239.6}{25} = \underline{9.58 \text{ A}}$$

Current through each resistor = 9.58 A

Delta configuration

$$V_L = V_{ph}$$

$$V_{ph} = \underline{415 \text{ V}}$$

Voltage across each resistor = 415 V

$$I_{ph} = \frac{V_{ph}}{R_{ph}} = \frac{415}{25} = \underline{16.6 \text{ A}}$$

Current through each resistor = 16.6 A

Question 19

Three heating elements are connected in star across a three phase, 415 V line. If 10 A flows in each line wire, determine:

- (a) the resistance of each heating element
 (b) the power drawn from the supply by the three elements.

$$V_L = \sqrt{3} V_{ph}$$

$$V_{ph} = \frac{V_L}{\sqrt{3}} = \frac{415}{\sqrt{3}} = \underline{239.6 \text{ V}}$$

$$I_L = I_{ph} = 10 \text{ A}$$

$$R_{ph} = \frac{V_{ph}}{I_{ph}} = \frac{239.6}{10} = \underline{23.96 \Omega}$$

Resistance of each heating element = 23.96Ω

$$P = \sqrt{3} V_L I_L$$

$$P = \sqrt{3} \times 415 \times 10$$

$$\underline{P = 7188 \text{ W}}$$

or

$$P = 3 V_{ph} I_{ph}$$

$$P = 3 \times 239.6 \times 10$$

$$\underline{P = 7188 \text{ W}}$$

$$\underline{P = 7.19 \text{ kW}}$$

Power drawn from the supply by the three elements = 7.19 kW

Question 20

Briefly state what a block diagram of an electrical circuit represents.

The block diagram is one in which blocks are drawn to represent complete component circuits or elements. The blocks are joined by flow lines to indicate the sequence of operation.

Question 21

What is the main difference between a schematic circuit diagram and a wiring diagram ?

The main difference is that in a schematic circuit diagram, controls, contacts, connections and conductors are not shown in their relative physical positions in the circuit but in their electrical relationship to each other. Whereas in a wiring diagram all components are shown in their correct places.

Question 22

Draw a circuit diagram of the control circuit and main circuit for a three phase D.O.L. motor starter.

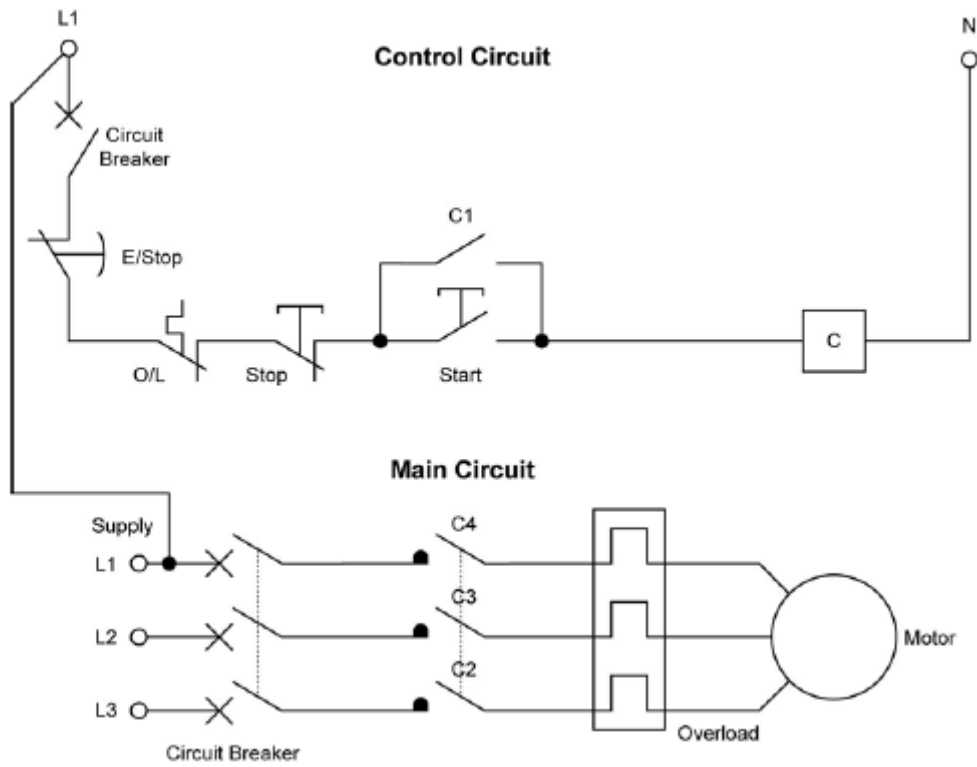

ELECTRICAL SAFETY OF PERSONNEL - POSSIBLE QUESTIONS

1. Describe THREE hazardous conditions that could occur in an installation with a high-prospective short-circuit current level.

- **Electric Shock**
- **Hazard to Life**
- **Fire**
- **Explosion**
- **Building and General Property Damage**

2. Danger tags and out-of-service tags are designed to promote safety in the workplace. State the colours used to identify EACH of the following:

- danger tags

Red Borders, Red Lettering on White background

- out-of-service tags

Black / Yellow Stripes, Black Lettering on White background

3. Give a brief description of the use of each type of tag, and clearly state how their use differs.

Danger Tag :

**Used to protect people, both worker and his/her workmates.
Used while person is working on the job/machine.**

Out of Service Tag:

**Used to stop people using unsafe equipment or machinery.
(i.e. repair etc. has stopped but machine still not usable)**

4. List THREE precautions to be taken when attaching a danger tag to an isolating switch.

- **Tag the correct piece of equipment.**
- **Make sure switch or control is in the correct non-dangerous position for tagging.**
- **Fasten the danger Tag securely so it won't come off.**

5. Detail the precautions relating to the removal of a danger tag.

When the job is finished or work is stopped at the end of a shift, each worker must remove his tag. However if it could be dangerous or could damage machinery when somebody operated the machine/valve switch etc., then an Out-of-Service Tag must be fastened to it.

6. State who may remove a danger tag and under what circumstances.

**At the end of a job - the person who tagged.
Or Supervisor at the end of job/shift if he/she is absolutely certain by checking, that no danger exists.**

THEORY

7. If a person receives an electric shock and the current magnitude is within a certain range, a state known as 'ventricular fibrillation' can occur.

a) Explain the effect of this condition

The heart contracts in a random way and cannot maintain circulation. Reversion to normal rhythm rarely occurs spontaneously and if the condition persists for more than a few minutes, the result is almost certain to be fatal.

b) State four factors that affect the severity of electric shock upon the human body

1. **Magnitude of the voltage**
2. **Duration of shock contact**
3. **Path of the current**
4. **Frequency**
5. **Physical condition of the victim**
6. **The phase of the heart cycle at the instant the shock occurs**
7. **Whether working conditions are wet**
8. **Type of supply (a.c. or d.c.) with which contact is made**
9. **The resistance offered by the human body (hard dry skin has a high resistance whereas moist skin has a much lower resistance)**
10. **The value of the current that flows through the tissues**

8. Give two circumstances where an isolating switch could carry two safety Tags.

1. **When there are 2 workers working on the system.**
2. **When the supervisor/person in charge of the area thinks it is required, he may attach his tag as well.**

9. (a) You need to take a three-phase, 10 kW pump motor away for repair. You have isolated the motor and have disconnected the motor cables. The motor cables are still connected to the DOL starter. (ET26)

State TWO precautions which must be taken to ensure the safety of persons and property after you have completed the isolation and disconnection

(2 marks)

Any TWO of:

- **Each conductor must be insulated and made electrically safe.**
- **Protects the cable to prevent damage.**
- **Take steps to prevent access to the cables**

(b) How is "isolating" a three-phase machine different from just "switching off" the machine?

(3 marks)

- **Isolating means that the motor has been deliberately disconnected from the electricity supply and precautions taken to prevent reconnection.**
- **Switched off means that the electricity ceases to be supplied to the motor.**

9 (c) Describe THREE different methods of safely ensuring the continued isolation of a fixed-wired, three-phase machine.

(3 marks)

Any THREE of:

- **Attach a safety warning tag.**
- **Lock open the isolating switch.**
- **Move the fuse carriers of the fuses controlling the circuit supplying the motor to a safe location.**
- **Use an access permit or hold card system.**
- **Disconnect the circuit supplying the motor at source.**

(d) State the TWO reasons why the prove-test-prove method of testing for isolation is used.

(2 marks)

- **To ensure that the test meter/instrument operates correctly during the procedure.**
- **To ensure that the circuit has been isolated before it is worked on.**

10. (a) The figure below represents a low voltage, three-phase 400V supply to an electrical installation. The installation is live. (ET28)

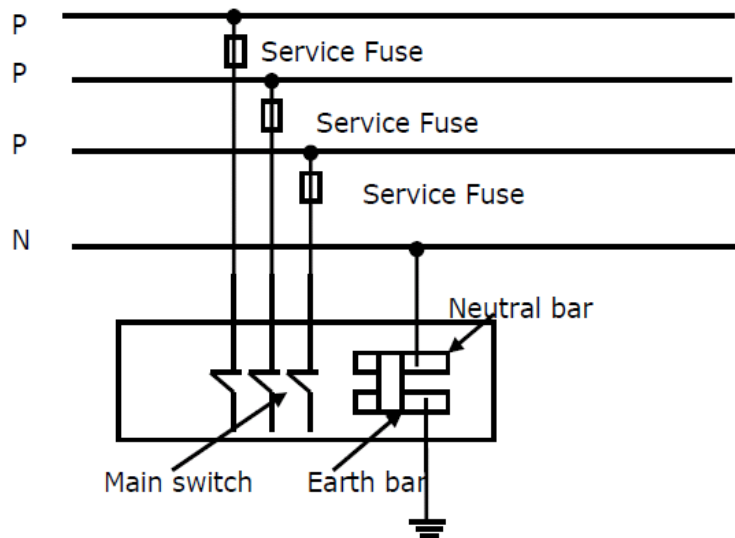

Three-phase consumer switchboard

State THREE hazards that will occur if any one of the three phases and the neutral are transposed at a point between the distribution line and the switchboard.

(3 marks)

Any THREE of:

- **Any metal not normally live could be live.**
- **If the earth fault path is of high impedance the main fuse may not blow.**
- **Fire hazard could occur through the main earth conductor carrying excessive current.**
- **The earth bar/neutral bar/MEN link could be live at up to 230V.**
- **The neutral is being switched.**
- **400V could be present at any socket outlet.**
- **Damage could occur to any 400V appliance/motor.**
- **Lighting circuits could have 400V present at the socket.**

THEORY

10 (b) From the figure in (a) above:

(i) Describe how you would carry out an instrument test to establish whether a phase/neutral transposition has taken place. Include in your description the type of instrument and equipment used. (2 marks)

- Use a voltmeter, remote earth and trailing lead.
- Take a voltage test at the main switch between each phase and the remote earth.
Or
- Take a voltage test between the earth/neutral bar and the remote earth.
Or
- Take a voltage test between the metal enclosure of the meter box and the remote earth.

(ii) State the expected instrument readings when no transposition has taken place. (2 marks)

- The reading between the main switch and remote earth for each of the phases should be about 230V.
- The reading between the neutral/earth bar and the remote earth should be about 0 volts.

(iii) State the expected instrument readings when a transposition has taken place. (3 marks)

- The reading at the main switch for the transposed phase should be about 0V.
- The reading at the main switch for the two phases not transposed should be about 230 V.
- The reading between the neutral/earth bar and the remote earth should be about 230 V.

NB: The removal of the MEN link with the installation live is hazardous.

No marks for stating $P - N = 230V$

11. Note: Read the entire question before commencing. The figure below represents a three-phase electric hot-water cylinder in an industrial plant. It comprises 3 single-phase 2 kW elements controlled by a contactor. The 230V contactor control circuit comprises a coil controlled by the water heater thermostat. The cylinder is controlled by an adjacent isolating switch (not shown) and is connected via flexible conduit and cables from the contactor. The circuit supplying the cylinder is protected by HRC fuses at the switchboard.

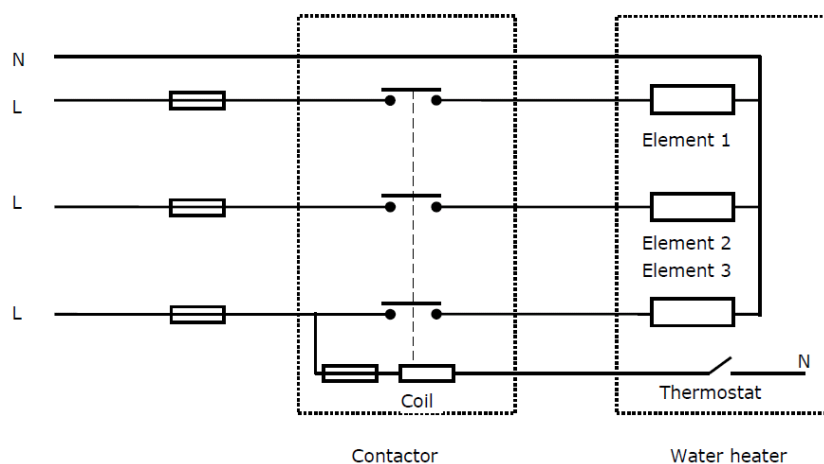

The cylinder is faulty and the isolating switch cannot be operated because the handle is broken. You have been requested to make the necessary repairs to the cylinder and replace the isolating switch. (ET28)

Question 11 continued

(a) Describe how you would safely isolate the cylinder and its isolating switch so the switch can be replaced and the cylinder repaired.

(4 marks)

- **Identify and remove the correct fuses on the switchboard.**
- **Attach a Danger tag to the circuit.**
- **Remove the isolator cover and test for voltage at the supply side of the isolator using the prove-test-prove method.**

(b) The following faults on the cylinder have been reported:

- The fuse to element 1 has blown. When it was replaced, it blew immediately.
- The fuse to element 2 blows at intermittent intervals.
Before you isolated the cylinder you found that:
- The cylinder is still operating on one element.
- No fault exists between the switchboard and the supply side of the isolator.
- The contactor is not faulty.

(i) Why does the cylinder operate on one element with two fuses blown?

(1 mark)

- **The control circuit operates at 230V.**
- **The control circuit is connected to the phase on which there is no fault.**

(ii) Describe the likely causes of the fault to element 1.

(2 marks)

- **Short between phase and earth in the wiring.**
- **Short between phase and neutral in the wiring.**
- **Short between phase and earth in the element.**
- **Short between phase and neutral in the element.**

(iii) Describe the likely causes of the fault to element 2.

(1 mark)

- **There is a breakdown in the insulation wiring between one phase and earth.**
- **One element has an insulation resistance of less than 10,000 ohms.**

(iv) State the type of test you would carry out to determine the location of the fault on element 1.

(1 mark)

- **Circuit continuity test (for the last bullet point in (ii) above.**
- **Insulation resistance test (for the first three bullet points in (ii) above.**

(v) State the type of test you would carry out to determine the location of the fault on element 2.

(1 mark)

- **Insulation resistance test.**

THEORY

12. Note: Read the entire question before answering it. You have completely rewired a three-phase shop that is metered on a remote panel. The work included all final subcircuits including a fixed wired, singlephase 2 kW water heater. There was no change to the mains, main earthing system or switchboard. To complete the work you need to carry out an insulation resistance test of the work you have done and the installation is live. (ET30)

- (a) Describe the actions you will take to ensure that the electrical installation is isolated so it is safe to carry out the insulation resistance test. (1½ marks)
- **Using the prove-test-prove method to ensure load side of the switch is isolated.**
 - **Attach a danger tag to the main switch.**

- 12(b) For the insulation resistance test state:
The type of instrument you will use.
The test voltage – if applicable (1 mark)
- **An insulation resistance tester**
 - **500V d.c. test voltage**

- (c) Describe how you will carry out the insulation resistance test on the shop. Include in your description the permitted minimum value of any test results. (3½ marks)
- **The MEN link and main neutral disconnected.**
 - **All switches and circuit breakers in the ON position.**
 - **Bridging between phase and neutral in turn - testing between each phase / neutral and earth.**
 - **A minimum of 1 MΩ test value for the installation.**

- (d) When you tested the installation the test result was 0.2 M. You proceeded to certify the installation on a Certificate of Compliance as it complied with AS/NZS 3000. Describe the actions and further tests you took to verify that the installation complied with AS/NZS 3000. Include in your description the permitted minimum value of any test results. (4 marks)
- **Disconnect the water heater.**
 - **Retest as per (c) above.**
 - **Minimum of 1 MΩ test value for the installation.**
 - **Test between phase/neutral and earth of the water heater.**
 - **Minimum value of 10000Ω for the water heater.**

13. (a) Danger tags and out-of-service tags are designed to promote safety in the workplace.

- (i) Give a brief description of circumstances when a Danger Tag is used. (1 mark)
- **Where there is a possibility of personal danger through the supply being restored.**

- (ii) Give a brief description of circumstances when an Out-of-Service Tag is used. (1 mark)
- **Where equipment is faulty or damaged and using that equipment would cause damage or injury.**

(iii) List THREE precautions to be taken when attaching a danger tag to an isolating switch.

(3 marks)

Any THREE of:

- **Make sure the correct isolating switch is tagged.**
- **Make sure the switch is in the OFF position before it is tagged.**
- **Fasten the Danger Tag securely so that it will not come off.**
- **Test to ensure isolation has taken place.**
- **Appropriate details are entered on the tag.**

(b) Explain the difference between:

A 10 kW pump motor that has been "isolated". and

A 10 kW pump motor that has been "switched off".

(3 marks)

- **Isolated means that the motor has been:**
 - **Deliberately disconnected from the electricity supply and**
 - **Precautions taken to prevent reconnection.**
- **Switched off means that the electricity ceases to be supplied to the motor.**

(c) Describe how the prove-test-prove method of testing is carried out.

(1½ marks)

- **The test instrument is checked to be operating correctly on a known live source.**
- **The equipment is tested to confirm that it is isolated.**
- **The instrument is again checked on a known live source to ensure it still operates correctly.**

(d) You are using the prove-test prove method at the supply side of a threephase main switch to see if the switchboard is isolated. What tests would you make to clearly establish that isolation (or otherwise) has taken place.

(½ mark)

- **Test between each phase and earth.**

Supply Systems - Possible Questions

- 1 List TWO advantages, other than cost, that a three phase system has over a single phase supply system. (N99)
 - **Smoother running three phase motors.**
 - **Simpler construction of three phase motors.**
 - **Three phase motors are self starting.**
 - **Smaller electrical equipment.**
 - **Better utilisation of electrical equipment eg. Less copper needed in circuits, smaller switchgear etc.**

- 2 Why is it desirable to balance single phase subcircuits in a three phase installation?(J99)
 - **To maximise the use of all capital equipment (cables, transformers etc.)**
 - **To minimise voltdrop/neutral currents**

- 3 Three resistive loads of 10kW, 15kW and 25kW are star connected to a 400V, three phase supply.
 - a) Calculate the current in each line.
 - b) Determine the current in the neutral.
 - c) Calculate the total power supplied.
 - d) Briefly describe what would occur to the phase voltages across the load resistors(calculations not required) if the neutral became disconnected.(J99)

a)

$$R_L = \frac{P}{V}$$

$$= \frac{10000}{230}$$

$$= \underline{43.5 \text{ A}}$$

$$Y_L = \frac{15000}{230}$$

$$= \underline{65 \text{ A}}$$

$$B_L = \frac{25000}{230}$$

$$= \underline{108.7 \text{ A}}$$

b)

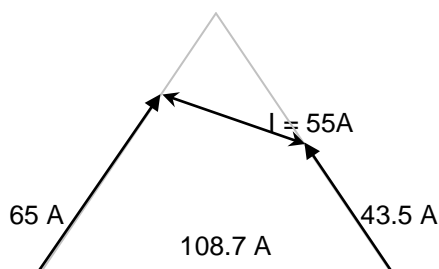

c)

$$P_t = P_1 + P_2 + P_3$$

$$P_t = 10 + 15 + 25$$

$$P_t = \underline{50 \text{ kW}}$$

d) **The phase voltage would float up and down depending on their respective loads**

4 Sketch and label a diagram to show how a three phase, 400 V distribution switchboard in an engineering workshop can be supplied from an RCD on an MEN main switchboard.

Include the following in your diagram:

- MEN switchboard, including mains in, mains earth, N and E bars, main switch, circuit protection (fuses) and an RCD (block only)
- Cable supplying the distribution switchboard, including the number of cores.
- Distribution switchboard, including N and E bars, main switch, subcircuit protection(fuses) and subcircuit wiring to a single phase and a three phase circuit. (N00)

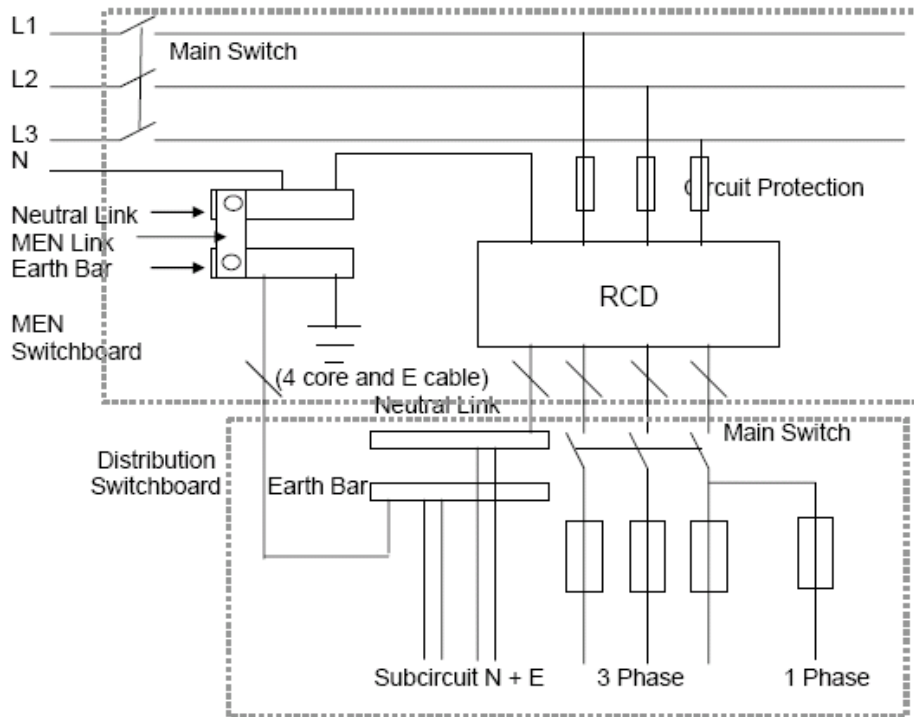

5 List TWO types of prime movers used to drive alternators. (J01)

- **Steam turbine**
- **Petrol diesel**
- **Water turbine**

6 State ONE technical reason for earthing the neutral in the MEN system of supply.(N02)

- **To provide a very low resistance circuit/path to the distribution transformer via the parallel paths of the neutral and earth conductors.**
- **To ensure a high fault current flow and rapid operation of the circuit protection in the event of an earth fault.**
- **To ensure the maximum voltage to earth is 230V**
- **To keep the voltage between neutral and earth to zero**
- **If the MSN fails (goes open circuit) the installation neutral potential is held to earth potential.**

THEORY

- 7 The figure below shows a standard MEN, two phase, 400/230V, low voltage supply to a rural property in New Zealand with four typical loads shown connected and turned on. R1 is a 1kW heater, R2 is an electric jug, R3 is a bathroom heat lamp (2 lamps) and R4 is the grill element in the oven. Point X represents an open circuit that suddenly occurs when the link joining two sections of the neutral busbar falls out.
- Calculate the current that will flow through R3 and R4.
 - Calculate the voltage that will be dropped across R3 and describe its likely effect on this particular appliance.
 - Calculate the voltage that will appear across R4, and describe its likely effect on this particular appliance. (N02)

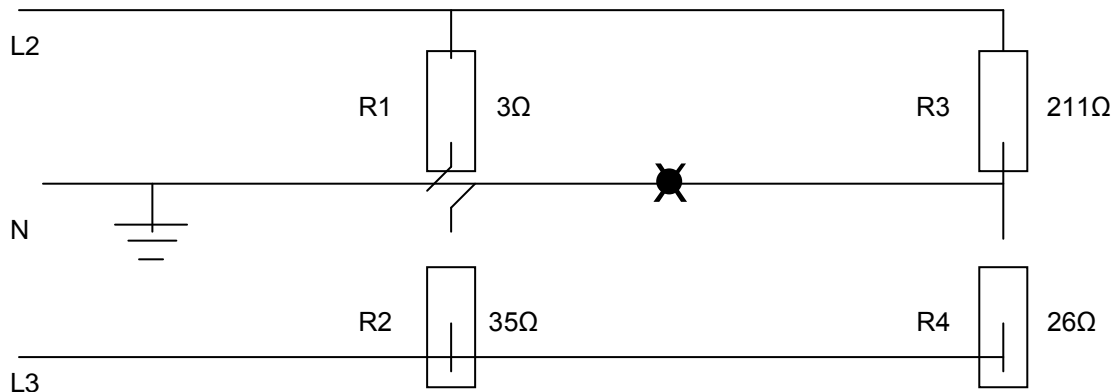

$$\begin{aligned} \text{a. } R_{\text{total}} &= R3 + R4 \\ &= 211 + 26 \\ &= 237 \Omega \end{aligned}$$

$$\begin{aligned} I &= \frac{V}{R} \\ &= \frac{400}{237} \\ &= 1.6878\text{A} \end{aligned}$$

$$\begin{aligned} \text{b. } V_{R3} &= I \times R \\ &= 1.6878 \times 211 \\ &= 356 \text{ V} \\ &\text{This voltage will blow (destroy) the lamp in the fitting.} \end{aligned}$$

$$\begin{aligned} \text{c. } V &= I \times R \\ &= 1.6878 \times 26 \\ &= 44 \text{ V} \\ &\text{This voltage must be insufficient to heat up the grill element.} \\ &\text{(and will be absent when the bulbs blow anyway)} \end{aligned}$$

- 8 List TWO types of earth electrode that may be used to connect the MEN system to the mass of the earth. (J03)
- Earth rod
 - Buried conductors
 - Metallic reinforcing

- 9 With reference to a single phase MEN system, briefly explain what is meant by the term, **standard low voltage**.

It means a nominal voltage of 230 volts a.c. between phase and neutral.

- a) Explain what is meant by a Multiple Earthed Neutral System.

A multiple Earthed Neutral System means a system of supply of electricity in which the neutral is connected to earth

- a) **At the source of supply; and**
 b) **At points on the supply system; and**
 c) **At every electrical installation connected to that system**

- 10 (a) Sketch and label a simple diagram to represent an MEN distribution system showing. (ET21)

- A delta-star-connected 11 kV/400 V supply transformer including output lines
- A single-phase consumer including main switch, and neutral and earth bar connections
- A three-phase consumer including main switch, and neutral and earth bar connections
- All earthing arrangements.

(5 marks)

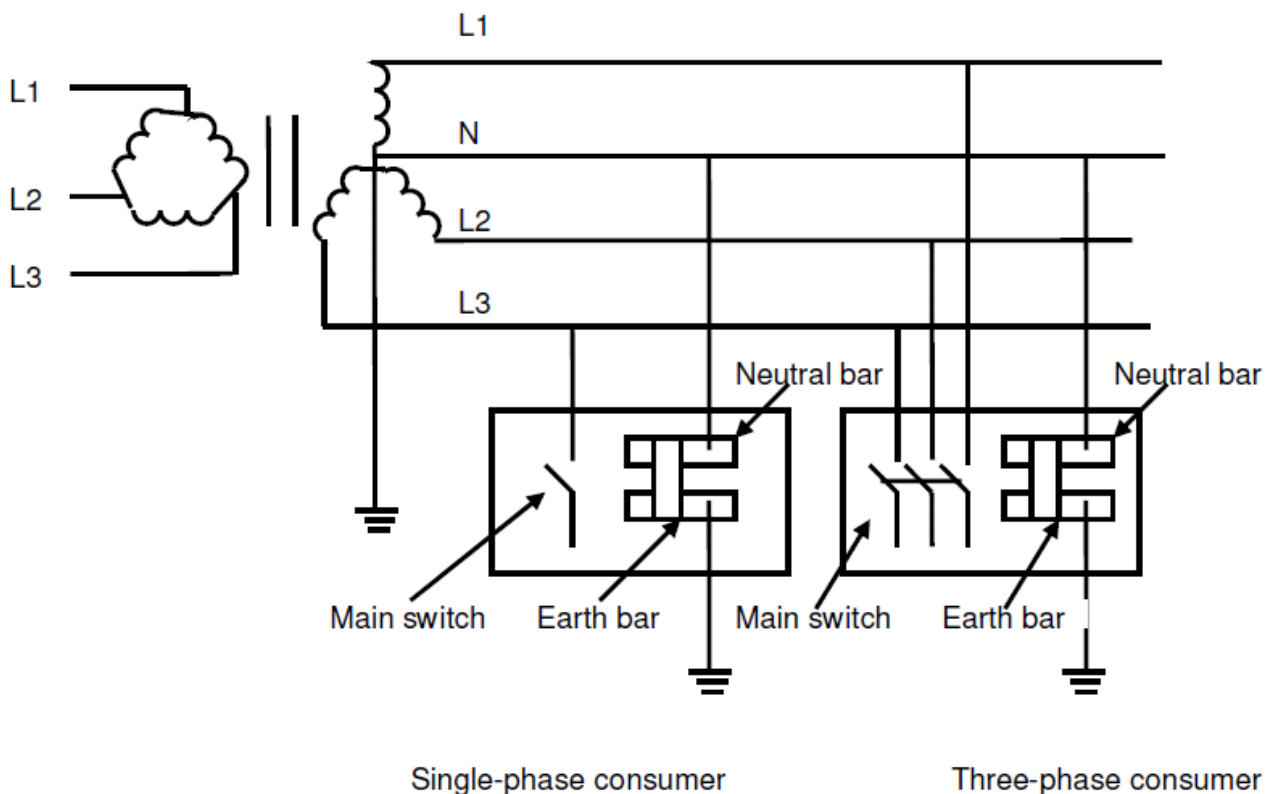

11

(b) State TWO reasons why an MEN system is used in New Zealand.

(2 marks)

Any TWO of:

- The neutral ensures a low impedance fault loop on an earth fault.
- The lower the resistance of the fault circuit, the higher the fault current and the more reliable the operation of protection equipment.
- Limits the voltage to 230 V to earth.
- Mass of earth provides an alternative return path for the current if neutral is lost.

(c) State TWO main differences between an MEN switchboard and a distribution switchboard?

(2 marks)

Any TWO of:

- An MEN switchboard has an MEN link between the neutral and earth busbars or a distribution switchboard has no MEN link between the neutral and earth bars.
- An MEN switchboard is connected to earth via an earth electrode or a distribution switchboard is connected to earth via an MEN switchboard.
- An MEN switchboard can be the closest switchboard to the point of supply or a distribution switchboard cannot be the closest switchboard to the point of supply.

(d) What type of switchboard must be the first switchboard (closest to the point of supply) in an MEN electrical installation ?

(1 mark)

- **MEN switchboard.**

12. (a) Draw and label a diagram to represent the supply arrangements for an MEN distribution system that includes: (ET26)

- A delta-star-connected 11 kV/400 V supply transformer showing the neutral and earthing arrangements
- The conductors supplying a single-phase consumer installation and a three phase consumer installation
- The single-phase consumer switchboard that shows the main switch, neutral and earthing arrangements
- The three-phase consumer switchboard that shows the main switch, neutral and earthing arrangements
- Fuse protection for each installation

(4 marks)

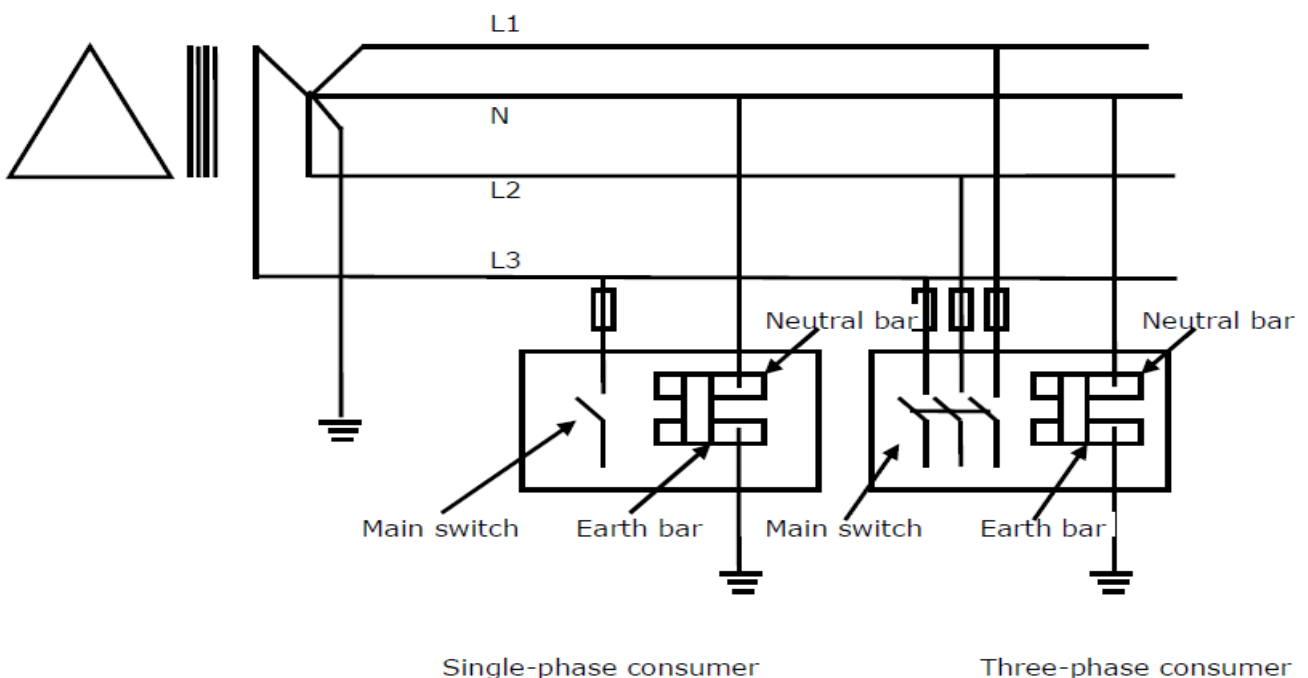

12 (b) State TWO reasons why the neutral conductor is earthed in an MEN system.

(2 marks)

Any TWO of:

- **The neutral ensures a low impedance fault loop on an earth fault.**
- **Limits the voltage to the nominal phase voltage.**
- **Mass of earth provides an alternative return path for the current if neutral is lost.**
- **To attempt to maintain the neutral at earth potential.**

(c) State TWO factors that limit the prospective short-circuit current in an electrical installation.

(2 marks)

Any TWO of:

- **Capacity of the supply source.**
- **Transformer impedance.**
- **Circuit impedance from the transformer to the switchboard (length of cable run)**

(d) Describe FOUR electrical hazards that may occur in a low voltage installation if the impedance of the main neutral is higher than the impedance of main earth.

(2 marks)

Any FOUR of:

- **A touch voltage hazard between conductive parts and the mass of the earth.**
- **Protective devices may not operate under fault conditions.**
- **Fire hazard at any high resistance joint in the main neutral.**
- **Fire hazard because the main earthing conductor is carrying a higher current than it can safely carry continuously.**
- **Over or under voltage could damage equipment – particularly on three phase installations.**
- **Damage could occur on neighbouring electrical installation due to load current passing through earth.**

13. (a) A small 400V, three-phase, 4-wire commercial installation has the following resistive loads on each phase:- (ET28)

- Red 30kW
- White 20kW
- Blue 10kW

(i) Calculate the line current in each of the three phases.

(5 marks)

Red phase current

$$\begin{aligned} I &= \frac{P}{V} \\ &= \frac{30000}{230} \\ &= 130.4A \end{aligned}$$

White phase current

$$\begin{aligned} I &= \frac{P}{V} \\ &= \frac{20000}{230} \\ &= 86.9A \end{aligned}$$

Blue phase current

$$\begin{aligned} I &= \frac{P}{V} \\ &= \frac{10000}{230} \\ &= 43.5A \end{aligned}$$

THEORY

(ii) Calculate the total power of the installation

(1 mark)

(ii) Total 3 phase power,
$$P = R+W+B$$
$$= 30kW + 20kW + 10kW$$
$$= 60kW$$

13 continued (iii) Determine the neutral current by resolution of vectors

(3 marks)

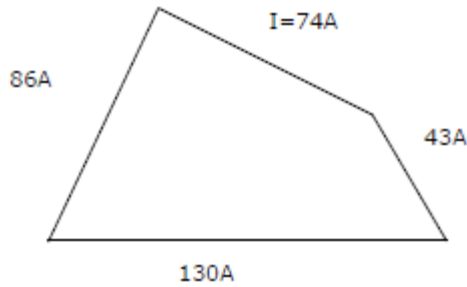

- ½ mark for each correct current (2 marks)
- I = 74A (accept any answer between 72 and 76A) (1 mark)

(b) State ONE technical reason why it is important to balance the load across the three phases of the installation?

(1 mark)

Any ONE of:

- Minimises outage or overload on highest loaded phase.
- Reduces voltage drop on highest loaded phase and on neutral.
- Eliminates overheating of components or fittings.
- Reduces capacity of individual components of the supply.
- Reduces the neutral current.

14. (a) This diagram represents a single phase domestic installation. The current in the phase is 20A, the neutral 10A and the main earth is 10A.

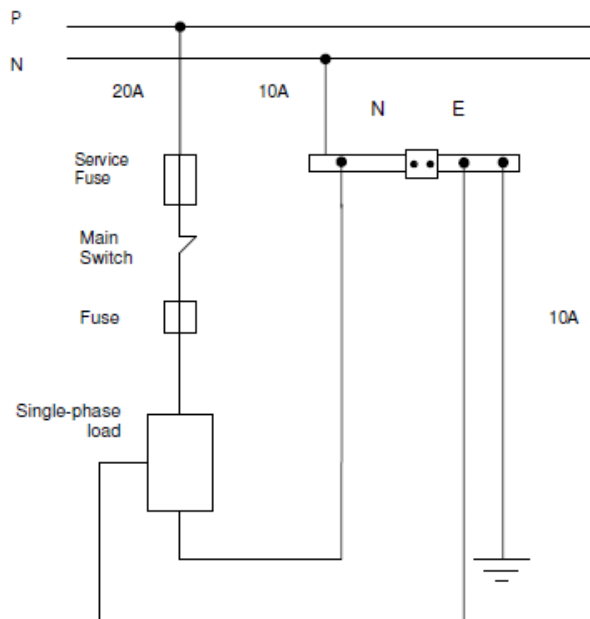

(i) Give TWO reasons why the neutral and earth of the installation carry the same current?

(2 marks)

- **The impedance of the neutral and earth are equal.**
- **Therefore, the neutral must have a high resistance joint.**

(ii) Explain why the main earth in the installation is effective.

(1 mark)

Any ONE of:

- **It has taken half of the load, as the earth usually takes a small percentage of the load.**
- **The impedance of the circuit to earth is low.**

(b) State THREE main features that distinguish an MEN switchboard from a distribution switchboard?

(3 marks)

- **It has an MEN link between the neutral and earth busbars.**
- **It is connected to earth via an earth electrode.**
- **It can be the closest switchboard to the point of supply.**

(c) State TWO factors that limit the prospective short-circuit current in an electrical installation.

(2 marks)

Any TWO of:

- **Capacity of the supply source**
- **Transformer impedance**
- **Circuit impedance or length of cable run or distance from the transformer to the switchboard.**
- **Supply voltage**
- **The cut-off characteristic of the protective device.**

(d) In the New Zealand low voltage MEN distribution system the neutral is earthed. State TWO points on the MEN distribution system where the neutral is earthed.

(2 marks)

Any TWO of:

- **At the star point of the distribution transformer**
- **Another point along the distribution line**
- **At the consumers premises.**

Circuit Protection - Possible Questions

1 State the TWO types of operation employed by most circuit breakers. (J03)

- **Thermal**
- **Magnetic**

2 Why is it important that an RCD is tripped before each use? (J03)

To ensure it has not frozen closed.

3 How many earthing conductors does a monitored earth circuit require? (J03)

Two

4 Give an application where a three phase motor would require phase reversal protection? (J03)

Any machinery where reverse operation may cause harm to people or damage to property. Eg. Compressor or Conveyor belt

5 The figure below represents 3 fluorescent lights supplied from a 230V MEN supply. The circuit is protected by a 16A, 6kA circuit breaker at the switchboard. Each fluorescent fitting is protected by a 1A glass cartridge fuse. (J03)

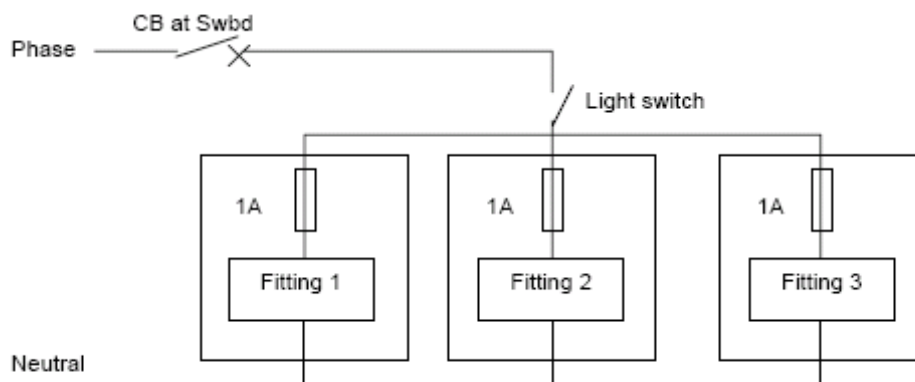

Fig 1

a) If a voltmeter were connected across the terminals of the circuit breaker what voltage would it read when:

- i. the light switch and circuit breaker are both closed?
0 Volts
- ii. The light switch is closed, but the circuit breaker is open?
230 Volts

b) Explain how back up protection is provided in the circuit in Fig1.

The circuit breaker has a higher prospective short circuit current rating and a quicker operating time than the fuses.

c) List TWO reasons why the glass cartridge fuses in the fluorescent fittings must not be shorted out or increased in current rating.

If a fault occurred:

- **the main circuit breaker would operate disconnecting all the lights in the circuit.**
- **The wiring and components in the light fittings may have a much lower current rating.**

- d) What is meant by discrimination as applied to circuit protection and how is discrimination achieved in Fig1.

Only the protection device closest to the fault operates so as to let the rest of the circuit continue to operate.

**By having each fitting fused at 1A and a 16A circuit breaker protecting the whole circuit.
The 1A fuse would operate first for a fitting fault.**

- 6 A three phase star connected pottery kiln draws 20A from a 400V supply and is protected by 32A fuses. A fault of 8 ohms has developed between one line and the kiln frame while the kiln is operating. Assume that the protective earth conductor resistance is 0 ohms and the fuse has a fusing factor (gG Utilisation Category) of 1.5 (J03)

- e) Sketch and label a circuit diagram of the circuit.

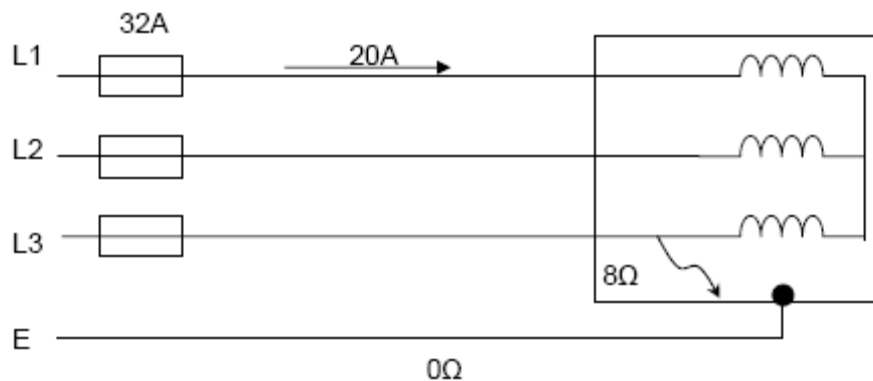

- b) i) Calculate the total current in the faulty line.

$$\begin{aligned}
 V_p &= \frac{V_L}{\sqrt{3}} & I_{\text{fault}} &= \frac{V}{R} \\
 &= \frac{400}{\sqrt{3}} & &= \frac{231}{8} \\
 &= 231\text{V} & &= 28.88\text{A}
 \end{aligned}$$

$$\begin{aligned}
 I_{\text{total}} &= I_{\text{fault}} + I_{\text{load}} \\
 &= 28.88 + 20 \\
 &= 48.88\text{A}
 \end{aligned}$$

- ii) Determine by calculation and state the effect if any, that this fault will have on the circuit protection.

The 32A fuses have a fusing factor (gG Utilisation Category) of 1.5

Fusing factor = 1.5 x 32 = 48A

Total current is 48.88A which is more than the fusing current of 48A.

The fuse will blow

- c) If the earth continuity conductor resistance to the kiln was 10 ohms and the same 8 ohms fault occurred between line and the kiln frame, explain with the aid of calculations, what electrical hazard this presents to the user.

$$\begin{aligned}
 I_{\text{fault}} &= \frac{V}{R} & I_{\text{total}} &= I_{\text{fault}} + I_{\text{load}} \\
 &= \frac{230}{(10 + 8)} & &= 12.78 + 20 \\
 &= 12.78\text{A} & &= 32.78\text{ A}
 \end{aligned}$$

Total current is 32.78A, which is less than the fusing current of 48A. The fuse will not blow.

Vd across earth conductor equals shock voltages

$$\begin{aligned}
 V_{\text{de}} &= I \times R \\
 &= 12.78 \times 10 \\
 &= \underline{127.8 \text{ volts}} \rightarrow
 \end{aligned}$$

Electrical shock hazard of 127.8 volt frame to earth exists.

- 8 An HRC fuse is labelled 80kA. Explain what this means.(N02)

Maximum breaking capacity is 80000 A.

- 9 There are a number of factors that limit the current at the fault location when a short circuit occurs in an electrical installation. List TWO of these factors.(N02)

Any two:

- **Capacity of the supply source**
- **Transformer impedance**
- **Circuit impedance**
- **Whether fault current limiters have been installed.**

- 10 A trolley mounted three phase pump is supplied from a monitored earth unit. With respect to either the wiring or the components used, list FOUR unique features of this form of protective device. (N02)

Any four:

- **A transformer that supplies extra low voltage for the control/earth circuit.**
- **An extra low voltage control circuit.**
- **A special plug and socket which has two separate earth terminals.**
- **Two separate earth points at the motor.**
- **Two earthing conductors between the monitored earth unit and the motor.**

- 11 HRC motor rated fuse links are capable of very fast operation and are commonly used to provide back up protection for the thermal overloads in a DOL three phase motor starter.(N02)

- a) Why do the thermal overloads need such protection when they are designed to trip out in response to a sustained overcurrent drawn by the motor.

Thermal overloads are not capable of safely interrupting the high levels of PSSC that HRCs can.

- b) With respect to the thermal overload unit, explain briefly the difference between and possible significance of a three phase trip and a single phase trip.

3-phase trip=uniform overcurrent across all 3 lines = motor overloaded.

1-phase trip=unbalanced overcurrent-line currents different = problem in motor or supply.

12 A three phase, 400V, 12kW star connected electric motor is operating at full load when a fault of 10 ohms occurs between Line 2 and the frame, which is earthed.

a) Sketch and label a circuit diagram of the circuit.

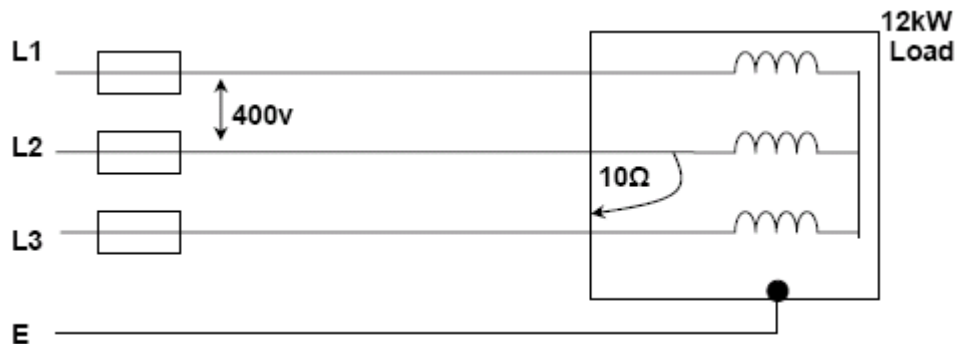

b) Calculate the power that is dissipated by this fault. (ignore the power taken by the motor, which continues to run)

$$\begin{aligned}
 \text{Fault current } >> & I = \frac{V}{R} \\
 & = \frac{230}{10} \\
 & = 23\text{A} \\
 \\
 \text{Power dissipated in fault} & W = I^2 \times R \\
 \text{resistance} >> & = 23^2 \times 10 \\
 & = 5290\text{W} \\
 \\
 \text{Or} & P = \frac{V^2}{R} \\
 & = \frac{230^2}{10} \\
 & = 5290\text{W}
 \end{aligned}$$

13 A single phase, class 1, plug in toaster has a 35 ohms fault between the phase conductor and the metal case, but is effectively earthed by the earth continuity conductor, which has a resistance of 0.1 ohms. Show by calculation, why there is insufficient voltage between the exposed metal case and earth to present an electric shock hazard.

$$\begin{aligned}
 \text{Fault current } >> & I = \frac{V}{R} \\
 & = \frac{230}{35} \\
 & = 6.57\text{A} \\
 \\
 \text{Fault Current flowing in ecc is } & 6.57\text{ A} \\
 \\
 \text{Voltage dropped across ecc } >> & V = I \times R \\
 & = 6.57 \times 0.1 \\
 & = 0.6571\text{ V}
 \end{aligned}$$

Voltage between toaster frame and earth = 0.6571 volts

(Which is insufficient to provide shock hazard to person touching toaster.)

14 State the maximum permitted operating time for an RCD used for personal protection on occurrence of an AC fault, where the current imbalance is equal to or greater than five times the rated residual current.

40 milliseconds.

15 A three phase, 400V, star connected lathe draws 20A from the supply and is protected by 32A motor rated fuses (gM @ 2.5). A fault of 12 ohms has occurred between line three and the machine frame while the machine was operating. Assume the earth continuity resistance is 0 ohms. (J02)

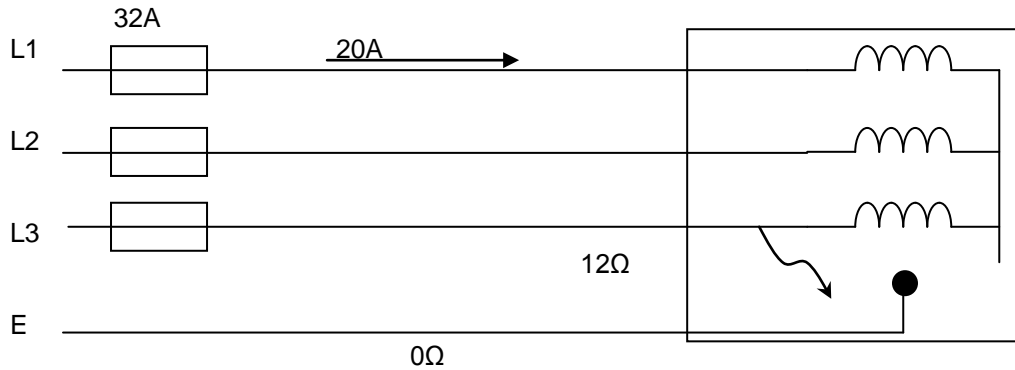

d) Calculate the total current in the faulty line.

$$\begin{aligned} \text{Current in the ECC} \quad I &= \frac{V}{R} \\ &= \frac{230}{12} \\ &= 19 \text{ A} \\ \text{Total current in the line} &= 19 + 20 = 39 \text{ A} \end{aligned}$$

e) Show by calculation the effect, if any, that this fault would have on the circuit protection.

Fusing factor of motor rated fuse is 2.5 so fusing current is 32 x 2.5 = 80A. This is greater than 39A line current. The circuit protection will not operate.

f) If the earth continuity resistance to the machine was 10 ohms and the same 12 ohms fault occurred between the line and the machine frame, explain in detail, including calculations, what hazard is presented to the user.

$$\begin{aligned} \text{Current in the ECC} \quad I &= \frac{V}{R} \\ &= \frac{230}{22} \\ &= 10.5 \text{ A} \end{aligned}$$

$$V_d \text{ across ECC} = 10.5 \times 10 = 105 \text{ V}$$

Shock hazard of 105V between the frame of the appliance and the earth.

16 The figure below shows an earth fault loop impedance tester plugged into a switched socket outlet of a domestic installation in order for a test to be carried out.

a) What is the purpose of the test ?

To ascertain that the earth fault loop impedance is of a sufficiently low value to enable the protective devices of the installation to operate within the required disconnection time.

Or

To determine the PSCC level so that correctly rated current limiting devices can be specified.

b) Show the path when meter testing the circuit below (J02)

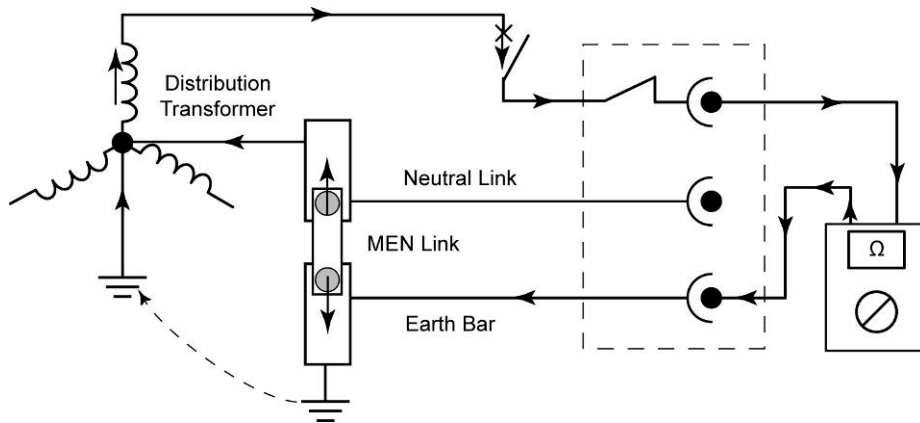

17 The Figure below shows time/current characteristic curves for a thermal overload device and an h.r.c. fuse used to protect an AC motor circuit.

a) With reference to Figure below, describe the sequence of events if the motor was to draw a line current of 60A for more than three minutes.

The thermal overload device would operate.

b) State why the thermal overload needs back up protection.

Because the thermal device is not capable of safely interrupting the level of prospective short circuit fault current that is likely to occur as a result of an earth fault on the circuit.

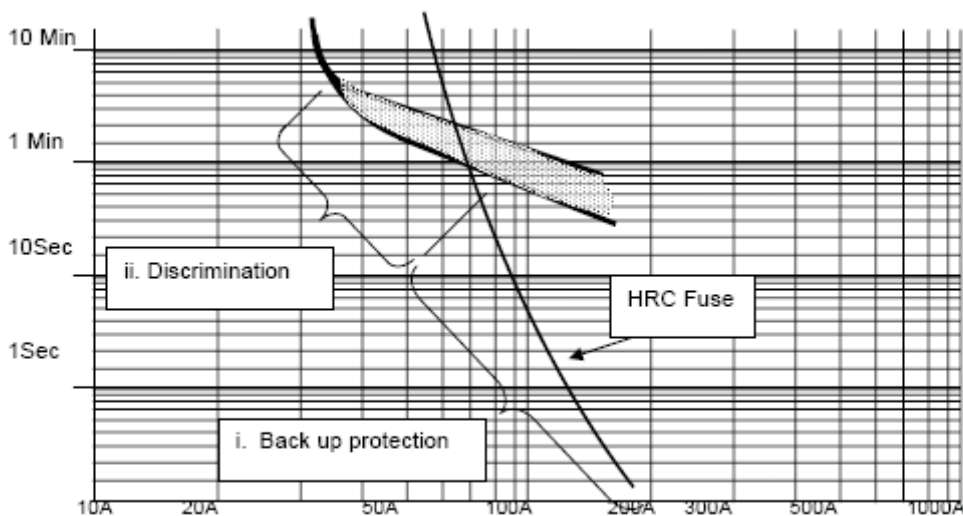

THEORY

- c) Each approved HRC type cartridge fuse, carries a label bearing information about its manufacturer and operating characteristics. An example of such information may include the following:-

i) 45 Amp ii) 415 Volt iii) AC 46

Briefly describe the meaning of each of these items of information.

- i) **This is the current rating of the fuse and it is the maximum current that a fuse can carry without deterioration.**
- ii) **The voltage that the fuse is designed to work at**
- iii) **The category of duty - simply refers to the type of current the fuse is rated to break (a.c. or d.c.) and the maximum current that will cause the fuse to rupture e.g. 46000A**

18 Comparing the devices below, complete the table by providing ONE advantage and ONE disadvantage for each.

	Advantages	Disadvantage
Circuit Breakers	<ul style="list-style-type: none"> • Easy to reset • Provides thermal and magnetic protection • Current rating can not be interfered with. 	<ul style="list-style-type: none"> • Not very fast operating speeds • Must wait to reset for thermal • Fixed fusing factor
HRC Fuse	<ul style="list-style-type: none"> • Available in several fusing factors • Good discrimination • Good back-up protection • Fast operation • Range of fusing factors • Higher rupturing capacity 	<ul style="list-style-type: none"> • Cost • Terminal configuration availability • Need to test to see if operated • Not easy to see if operated • Many different physical sizes available
Rewirable Fuse	<ul style="list-style-type: none"> • Rewirable • Cheap 	<ul style="list-style-type: none"> • Low rupturing capacity • Fusing Factor = 2 • Easy to replace with wrong size

19 Complete the following table by determining the missing information and then inserting it in each empty cell.

Fusing Factor (Range)	Rated current of fuse (A)	Current (A) that will blow the fuse (Range)	Category of Duty	PSCC Rating (kA)	Protection	Category
1.10 – 1.25	10	11.00 – 12.50	AC46	46	Close Yes	Coarse No
1.25 – 1.50	63	78.75 – 94.50	AC80	80	Yes	No
1.50 – 1.75	20	30.00 – 35.00	AC33	33	No	Yes
1.75 – 2.50	80	140.00 – 200.00	AC80	80	No	Yes

20 State the purpose of a phase failure relay. (N01)

- To disconnect the supply if one phase is lost.**
- OR:**
- To prevent damage to motor if one phase is lost.**

21 Why should the test button be operated before using a portable RCD for personal protection?(N01)

To ensure it has not frozen (stuck closed)

OR:

To test if it trips.

22 What is the maximum operating time at rated residual current for an RCD used for personal protection? (N01)

300mS

23 Define the term fusing factor as applied to circuit breakers.(N01)

The ratio of minimum fusing current to current rating.

24 Why must portable RCDs or isolating transformers be placed as close as practical to the socket outlet when used to supply portable power tools in outdoor or damp situations? (N01)

To ensure all equipment including leads etc, is protected.

25 Explain how HRC motor rated fuse links provide backup protection for the thermal overloads in a DOL starter supplying a three phase electric motor in the event of a short circuit.(N01)

Because the HRC fuse operates much faster than the thermal overload under short circuit conditions, the HRC fuse will disconnect the circuit before any damage occurs.

26 List the TWO most common forms of personal protection against electric shock used with electrical appliances either outdoors or in damp situations. (J01)

Isolating transformer and RCD.

27 Define the term back up protection as applied to circuit protection. (J01)

Protection with a higher PSCC rating protecting other protection with a lower PSCC rating.

28 List TWO types of protection offered to a motor by a direct on line starter. (J01)

Any two:

- **Low/no voltage**
- **Overcurrent**
- **Phase failure.**

29 Briefly describe the main construction features of a typical HRC fuse link. (J01)

An element is strung between the end caps and encased in a porcelain cylinder. The cylinder is filled with silica sand.

30 Explain how these features give a high rupturing capacity. (J01)

Because an HRC fuse can interrupt fault current faster or the arc quenching is better or faster because the sand collapses around melting element.

THEORY

31 An HRC fuse link is to be used to provide close excess current protection for a 2kW single phase heater that is to be permanently connected to a standard low voltage, MEN supply system. The installation has been tested with an earth fault loop impedance tester and found to have an impedance of 0.2 ohms. (N00)

- i) Show by calculation which of the following fuse links is most suitable for this application:
- 6A
 - 10A
 - 16A
 - 20A

$$I = \frac{P}{V}$$
$$= \frac{2000}{230}$$
$$= 8.7A$$

.....10A

- ii) What is the minimum voltage rating for the fuse?

230V (will accept 240 or 250)

- iii) Show by calculation the minimum breaking capacity required by the fuse.

$$PCC = \frac{V}{Z}$$
$$= \frac{230}{0.2}$$
$$= 1150A$$

- iv) What is the maximum fusing factor that will provide close excess current protection?

1.5

32 Explain the internal operation of a miniature circuit breaker when the following situations occur: (J00)

- a) small overload

Small overload: A small overload causes a bimetal to heat up and bend, operating a trip mechanism that disconnects the circuit.

- b) short circuit

Short circuit: A large overload causes a strong magnetic field, which attracts a trip mechanism that disconnects the circuit rapidly.

33 When an RCD is used for personal protection, state the: (J00)

- a) maximum residual operating current

30mA

- b) maximum operating time at maximum residual current

300 ms

34 Define the term breaking capacity when applied to a protective device such as a circuit breaker. (N99)

The maximum current the device can safely interrupt without sustaining any damage.

35 State the TWO principal operating advantages that an HRC fuse has over a miniature circuit breaker. (N99)

- (i) **Faster operation**
- (ii) **Can disconnect very high PSCCs safely.**

36 Explain the term inverse time current characteristic when applied to a protection device. (N99)

As current increases operating time reduces.

37 An HRC fuse link has the following details printed on it. (N99)

- a) Explain what each detail means and its relevance when installing the fuse link.

80 kA

80kA = Breaking capacity. Its is the maximum current the fuse can interrupt without sustaining any damages

If it is exceeding the fuse may be damaged, causing flashovers and consequently fire / or damages to other circuits components

10 A

10A = Current rating. It is the maximum current the fuse can carry continuously without deterioration

Any one

- **If the current rating is too low, the fuse will blow under normal load conditions**
- **If the current rating is too high, the fuse may not blow under fault or overload conditions**
- **If the current rating is too high, the fuse may not discriminate with other protection.**

550 V

550V = AC Voltage rating. The maximum circuit voltage the device can be connected to. If this is exceeded, it could cause flashovers, fire or consequential damage to circuit components.

- b) Define the term fusing factor when applied to an HRC fuse.

The ratio of the minimum fusing current to rated current.

- c) Sketch a time/current graph to show how an HRC fuse provides backup protection to a thermal overload.

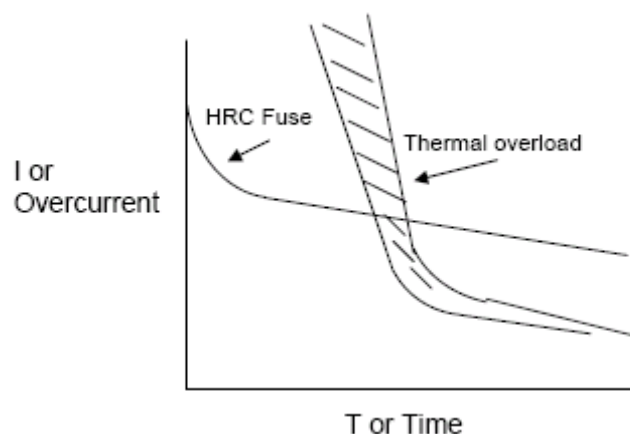

38

- a) Sketch and label a circuit diagram of an RCD used for personal protection that includes the following components:
- sensing coil/toroid
 - tripping device
 - test circuit (push button and resistor)
 - phase, neutral and earth conductors.

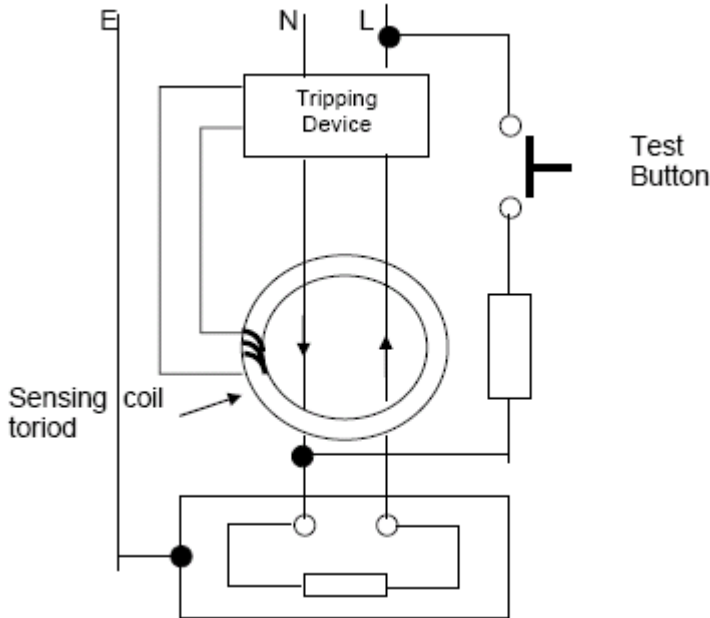

- b) Describe the operation of the RCD circuit when there is:

i) no fault

There is no out of balance current, so no magnetic field induced into the iron. Because there is no induced magnetic field there is no induced current in the sensing coil and the tripping coil is not energised.

ii) a phase to earth fault

There is an out of balance current, so magnetic field is induced into the iron. The induced magnetic field induces a current in the sensing coil and the tripping coil is energised, isolating the circuit.

38 Define the term rated current when applied to a protective device such as a fuse or circuit breaker. (J99)

The maximum current the device can carry continuously without deterioration.

40 The thermal protection device in a three phase motor starter is primarily designed to disconnect the motor on the occurrence of what type of fault? (J99)

Small overload of long duration.

41 State the TWO major dangers associated with short-circuits in circuits that have high prospective short-circuit currents. (J99)

**Damage to property
Harm to persons**

42 State **four** technical advantages that HRC cartridge fuses have over re-wireable fuses.

1. High Rupturing Current
2. Good Discrimination
3. Safe
4. Constant Fusing Time
5. Available in a range of fusing factors
6. Fast Operation

43. State TWO factors that limit the prospective short-circuit current in an electrical installation.(ET19)

Any TWO of:

- **Capacity of the supply source**
- **Transformer impedance**
- **Circuit impedance or length of cable run or distance from the transformer to the switchboard**
- **Supply voltage**

44. A 230V, 2 kW, Class I, single-phase heater is plugged in to a circuit protected by a 20A MCB. The MCB has a utilisation category (fusing factor) of 1.5. A phase-to-frame fault of 60Ω has occurred on the load side of the heater control switch

- a) On the diagram below:
Indicate the fault on the heater.
Draw in the earth fault loop

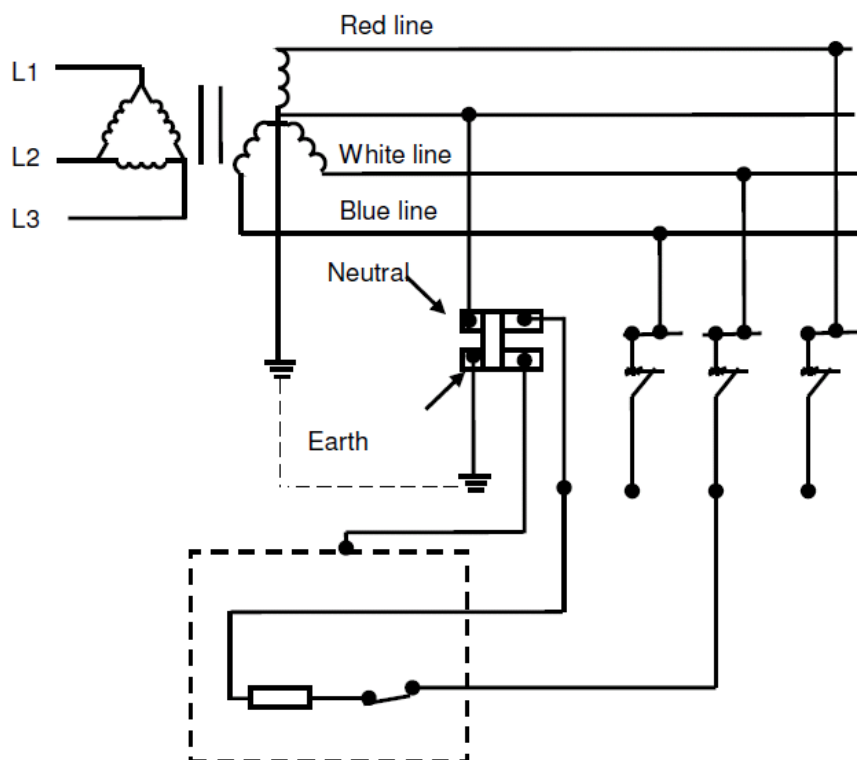

THEORY

(b) If the resistance of the appliance protective earthing conductor is 0.5 and the fault-loop impedance of the circuit is 0.67 ohms:

(i) Calculate the total current in the phase conductor.

$$\begin{aligned} I_{\text{load}} &= \frac{W}{V} & I_{\text{F}} &= \frac{230}{(0.5 + 0.67 + 60)} & I_{\text{T}} &= I_{\text{L}} + I_{\text{F}} \\ &= \frac{2000}{230} & &= 3.76\text{A} & &= 8.7 + 3.76 \\ &= 8.7 \text{ A} & & & &= 12.46\text{A} \end{aligned}$$

(ii) Determine by calculation whether the MCB will operate.

- **Fusing current of MCB is $20 \times 1.5 = 30\text{A}$**
- **As the total current is 12.46A, the MCB will not operate.**

(iii) State the TWO reasons why the high-resistance earth fault in the appliance increases the risk of electric shock when using the appliance in an earthed situation.

- **There will be a voltage difference between the frame of the appliance and earth presenting a shock hazard.**
- **The protection will not operate.**

45. Explain the following terms:

(2 marks)

PRCD

- **Portable residual current device.**

RCBO

- **Residual current circuit breaker with overload protection.**

46. A three-phase, 400 V, star-connected lathe draws 27 A from the supply and is protected by 32 A motor-rated fuses. A fault of 14 Ω has occurred between one line and the machine frame while the machine was operating. Assume the protective earthing conductor resistance is 0 Ω . (ET 21)

(a) Calculate the total current in the faulty line

(2 marks)

$$\text{Current in earth continuity conductor} = \frac{230}{14} = 16.4 \text{ A}$$

$$\text{Total current in the line} = 16.4 + 27 = 43.4 \text{ A}$$

(b) Show by calculation the effect, if any, that this fault would have on circuit protection.

(3 marks)

Fusing factor of motor-rated fuse is 2 (accept any factor in the range 1.75 – 2.5) so fusing current is $32 \times 2 = 64 \text{ A}$ (accept 56 – 80).

This is greater than the 43.4 A line current. The circuit protection will not operate.

(c) If the earth continuity resistance to the machine was 10 Ω and the same 14 Ω fault occurred between the line and the machine frame, explain in detail, including calculations, what hazard is presented to the user.

(5 marks)

$$\text{Current in earth continuity conductor} = \frac{230}{24} = 9.6 \text{ A}$$

$$\text{Voltdrop across earth continuity conductor} = 9.6 \times 10 = 96 \text{ V}$$

Shock hazard of 96 V between the frame of the appliance and earth.

THEORY

47. A three-phase star connected pottery kiln draws 20A from a 400V supply and is protected by 32A fuses. (ET24)

(a) A fault of 8Ω has developed between one line and the kiln frame while the kiln is operating. Assume that the protective earthing conductor resistance is 0Ω and the fuse has a fusing factor (gG Utilisation Category) of 1.5.

(i) Calculate the total current in the faulty line.

(3 marks)

$$\begin{aligned}V_{ph} &= \frac{V_L}{\sqrt{3}} \\ &= \frac{400}{\sqrt{3}} \\ &= 231V\end{aligned}$$

$$\begin{aligned}I_{fault} &= \frac{V}{R} \\ &= \frac{231}{8} \\ &= 28.88A\end{aligned}$$

$$\begin{aligned}I_{total} &= I_{fault} + I_{load} = 28.88 + 20 \\ &= 48.88A\end{aligned}$$

(ii) Determine by calculation and state the effect if any, that this fault will have on the circuit protection.

(2 marks)

The 32 A fuses have a fusing factor (gG Utilisation Category) of 1.5

Fusing current = $1.5 \times 32 = 48A$

Total current is 48.88, which is more than the fusing current of 48 A.

The fuses will operate

Or

The fuses will not operate within 0.4s

(b) A fault of $8W$ has developed between one line and the kiln frame while the kiln is operating and the protective earth conductor resistance to the kiln was $12W$.

(i) Calculate the total current in the faulty line

(2 marks)

$$\begin{aligned}I_{fault} &= \frac{230}{(12 + 8)} \\ &= 11.5A\end{aligned}$$

$$\begin{aligned}I_{total} &= I_{fault} + I_{load} = 11.5 + 20 \\ &= 31.5A\end{aligned}$$

(ii) Explain by calculations, what electrical hazard this presents to the user.

(3 marks)

**Total current is 31.5A, which is less than the rated current 32A.
The fuse will not operate as intended.**

Vd across earth conductor equals shock voltage

$$\begin{aligned} V_d &= I \times R \\ &= 11.5 \times 12 \\ &= 138V \end{aligned}$$

Electric shock hazard of 138V frame to earth exists

48. (a) The following graph shows the time/current characteristics of six HRC fuses.

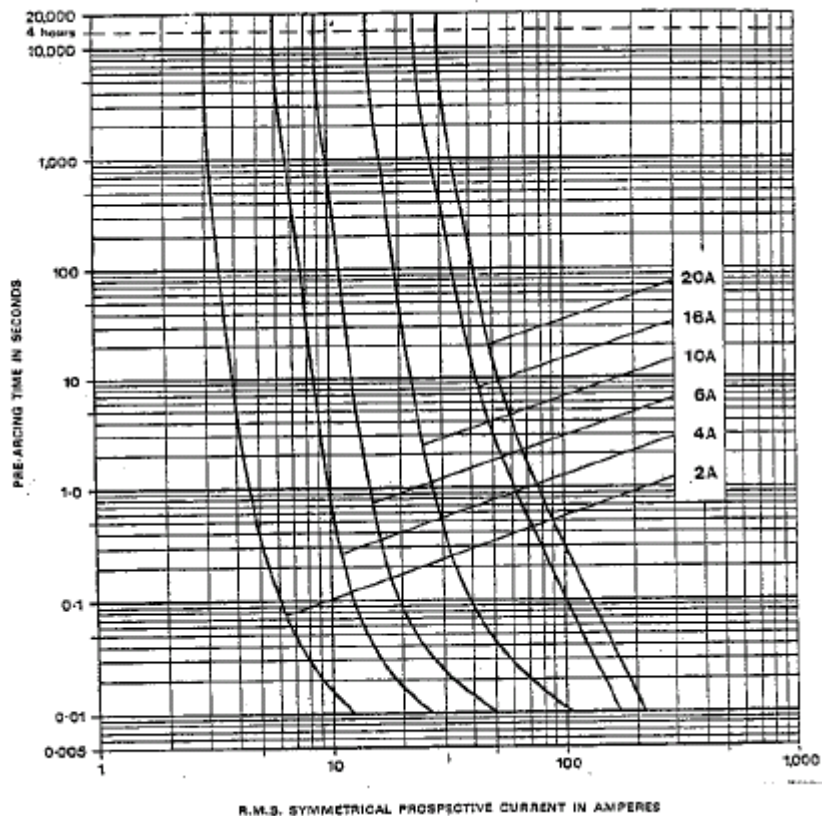

(i) Why is the graph referred to as an inverse time current characteristic graph? (ET26)

(2 marks)

- It shows that the higher the fault current
- The shorter the time it takes to trip.

(ii) Which fuse would trip when a current of 27A flows with a pre-arcing time of 1.0 second?

(1 mark)

- 10 A

(b) (i) What is the gG utilisation category (fusing factor) of a 6A rated fuse?

(1 mark)

- In the range between 1.2 and 1.5

(ii) What value of current will operate the 6A fuse?

(1 mark)

- Between 7.2A and 9.6A

THEORY

- (c) Describe what happens in an electrical installation when a fault occurs and there is “discrimination” between protective devices. (2 marks)
- **The protective device nearest the fault operates, before any other protective device.**

- (d) Under what circumstances must back-up protection be installed in a motor circuit? (2 marks)
- **To provide short-circuit protection when the existing protective devices have inadequate breaking capacity.**

- (e) What is meant by the term “current rating” when applied to fuses. (1 mark)
- **This is the maximum continuous current that the fuse can carry without deteriorating.**

49. (a) The circuit supplying a 230V, single-phase wash-down pump has both RCCB and MCB protection. The pump isolating switch has been replaced. (ET26)

- (i) What would be the effect if the phase and neutral were accidentally interchanged at the supply side of the isolating switch? (3 marks)

Any THREE of:

- **The protection will still be effective under fault conditions.**
- **The pump will operate normally.**
- **The neutral would be switched.**
- **The pump circuitry would be live when the isolating switch is in the “off” position.**

- (ii) What would be the effect if the neutral and earth were accidentally interchanged at the supply side of the isolating switch? (1 mark)
- **The RCCB will trip as the PEC would carry the return current.**

49(b) State ONE test that would detect the interchange of the phase and neutral conductors before the electricity supply is livened. (1 mark)

Any ONE of:

- **Circuit connections test (polarity)**
- **Visual check.**

- (c) A three-phase, 400V, four-wire distribution board has a load of 32A on the red phase, 12A on the white phase and 40A on the blue phase. Determine the neutral current using a graphical method. (5 marks)

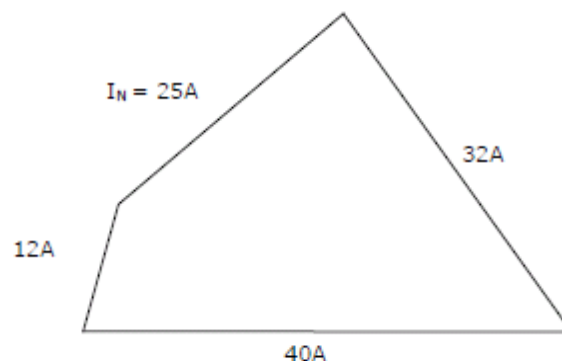

- Correct graphical representation
- Correct solution for $I_N = 25A$ (allow 23-27A)

50. A 400V, three-phase star-connected bakery oven is rated at 25 kW. The circuit is protected by 45A, gG type, HRC fuses with utilisation category (fusing factor) of 1.5. (ET26)

- (a) A fault of negligible impedance has developed between one line and the oven frame while the oven is operating. The protective earth conductor resistance is 0.75Ω. Calculate the total current in the faulty line

(1½ marks)

$$\begin{aligned}
 I_{\text{load}} &= \frac{P}{\sqrt{3} \times V} \\
 &= \frac{25000}{\sqrt{3} \times 400} \\
 &= 36.08\text{A} \\
 I_{\text{total}} &= I_{\text{fault}} + I_{\text{load}} \\
 &= 306.67 + 36.08 \\
 &= 342.68\text{A}
 \end{aligned}$$

(b) If fault was 15Ω impedance and the protective earth conductor resistance is 5Ω.

- (i) Calculate the total current in the faulty line

(5 marks)

$$\begin{aligned}
 I_{\text{load}} &= \frac{P}{\sqrt{3} \times V} \\
 &= \frac{25000}{\sqrt{3} \times 400} \\
 &= 36.08\text{A} \\
 I_{\text{fault}} &= \frac{230}{(15 + 5)} \\
 &= 11.5\text{A} \\
 I_{\text{total}} &= I_{\text{fault}} + I_{\text{load}} \\
 &= 36.08 + 11.5 \\
 &= 47.58\text{A}
 \end{aligned}$$

- (ii) Calculate whether the fuse will operate.

(1½ marks)

The 45A fuses have a fusing factor (gG Utilisation Category) of 1.5

Fusing current = 1.5 x 45 = 67.5 A

Total fault current is 47.58A so the fuse will not operate within the minimum disconnection time.

- (iii) Calculate the touch voltage that would appear on the frame of the oven.

(2 marks)

$$\begin{aligned}
 V_{dE} &= I \times R \\
 &= 11.5 \times 5 \\
 &= 57.5\text{V}
 \end{aligned}$$

THEORY

51. (a) Draw and label a circuit diagram of a three-phase RCD used for personal protection that protects a 5-pin socket outlet in a workshop. (ET28) (5 marks)

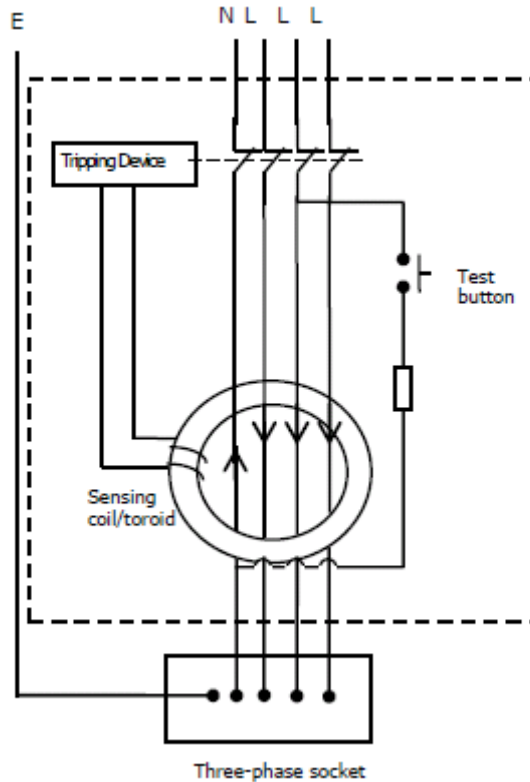

(b) Describe the operation of an RCD when there is an active (phase) to earth fault occurs on the circuit the RCD protects. (4 marks)

- Neutral current out of balance with the phase current.
- A magnetic field is induced into the iron core.
- The induced magnetic field induces a current in the sensing coil
- The tripping coil is energised, opening the RCD contacts.

(c) Define the term “RCBO” (1 mark)

- **Residual Current-Operated Circuit Breaker with Overcurrent Protection.**

51. The figure below represents a three-phase, star-connected 400V, 18 kW commercial oven. The oven is protected by 40A HRC fuses with a fusing factor (gG Utilisation Category) of 1.5. (ET28)
An earth fault of 6Ω has developed between L1 and the oven frame while the oven is operating. The fault occurred at point X.
The protective earthing conductor resistance is 9.75Ω due to a high resistance termination.

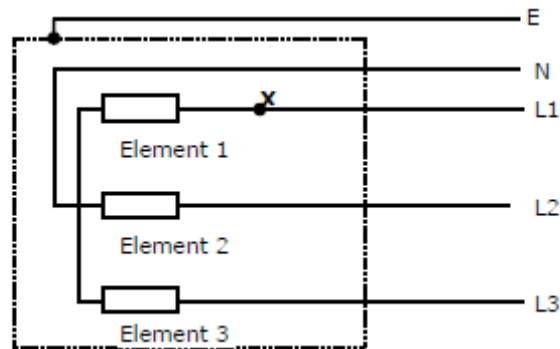

- (a) (i) Calculate the total current that will flow in L1 under the fault conditions.

(5 marks)

$$\begin{aligned} I_{ph} &= \frac{P}{V_L \times \sqrt{3}} \\ &= \frac{18000}{400 \times \sqrt{3}} \\ &= 25.98A \end{aligned}$$

$$\begin{aligned} I_{fault} &= \frac{V}{R} \\ &= \frac{231}{(6 + 9.75)} \\ &= 14.67A \end{aligned}$$

$$\begin{aligned} I_{total} &= I_{fault} + I_{load} = 14.67 + 25.98 \\ &= 40.65A \end{aligned}$$

- (ii) Explain by calculations:

- Whether the fuse protecting L1 will operate.

(1 mark)

**The 40A fuses have a fusing factor (gG Utilisation Category) of 1.5.
Fusing current = 1.5 x 40 = 60A**

Because the fault current is 40.65 the fuses will not operate or the fuses will not operate within 0.4s.

- Whether any hazard exists to the operator of the oven.

(2 marks)

$$\begin{aligned} V_d &= I \times R \\ &= 14.67 \times 9.75 \\ &= 142.35V \end{aligned}$$

Touch voltage Hazard of 142.35V exists between frame and earth.

THEORY

(b) If the fault at point X was of negligible impedance, calculate the maximum resistance in the protective earthing conductor that would ensure the fault current exceeded the fusing current of the fuse by a margin of 1A.

(2 marks)

$$\begin{aligned}
 I &= 61\text{A} \\
 R &= \frac{V}{I} \\
 &= \frac{230}{61} \\
 &= 3.77\Omega
 \end{aligned}$$

52. (a) The following graph shows the time/current characteristics of six HRC fuses. (ET30)

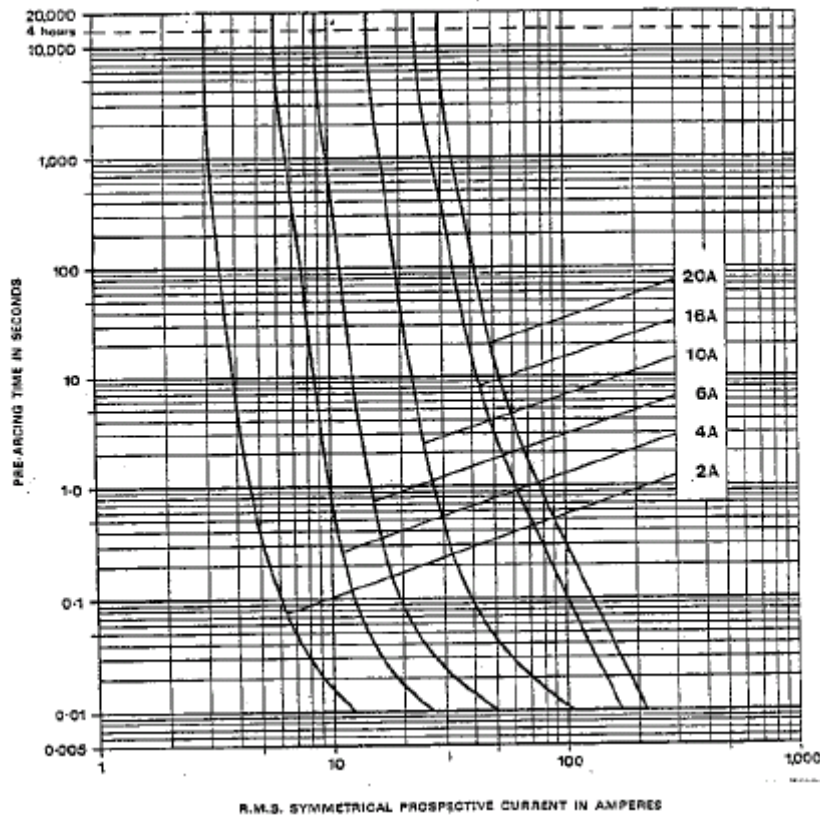

52(i) Which one of these fuses would blow (with a pre-arcing time of 0.1 seconds) when a current of 100A flows? Give a reason for your answer

(2 marks)

- Where 0.1 second line intersects with 100A line
- The fuse curve is that for 16A

(ii) Why is the graph referred to as an inverse-time current characteristic graph? Provide an example from the graph to support your answer.

(4 marks)

- It shows that the higher the fault current
- The lower the time it takes the fuse to trip

50A flowing in the 20A fuse will take about 18 seconds to blow. 100A flowing in the 20A fuse would take about 0.3 seconds.

- (b) (i) What is the fusing current of a 20A gG rated HRC fuse? (½ mark)
- **The fusing current is 30A (accept between 25A and 32)**
- (ii) What is the fusing current of a 20A gM rated HRC fuse? (½ mark)
- **The fusing current is 40A (accept between 32A and 50A)**
- (c) Give a brief description of what “discrimination” means when applied to protective devices. (1 mark)
- **The protective device nearest the fault operates, before any other protective device.**
- (d) Under what circumstances must back-up protection be installed in a motor circuit? (2 marks)
- **To provide short-circuit protection for the circuit as the thermal overload is not designed for this type of protection.**
53. (a) You have done an earth fault loop impedance test on a domestic installation and, from the test results, have calculated that the fault level is 1.2 kA. On the switchboard there are three rewirable fuses. State TWO reasons why you would replace the rewirable fuses with MCBs. (2 marks)
- **Rewireable fuses are not rated for more than 1 kA**
Or
Rewireable fuses will not safely rupture under the stated fault conditions.
 - **MCBs are rated for 3 to 6kA**
Or
MCBs will safely open under the stated fault conditions.
- (b) MCBs with both thermal and magnetic functions are installed on a switchboard in a factory.
- (i) Briefly describe the internal operation of the MCB when its thermal function operates. (2 marks)
- **A bi-metal strip heats up and distorts. The distortion operates a trip mechanism that opens the breaker.**
- (ii) Briefly describe the internal operation of the MCB when its magnetic function operates. (2 marks)
- **A strong magnetic field is created in the coil. The field attracts a trip mechanism that operates and opens the breaker.**
- (c) The following is a diagram of a 400V/230V MEN distribution system supplying a single-phase MEN switchboard and a three-phase MEN switchboard. Complete the diagram by drawing the components of the MEN system that are missing. (4 marks)

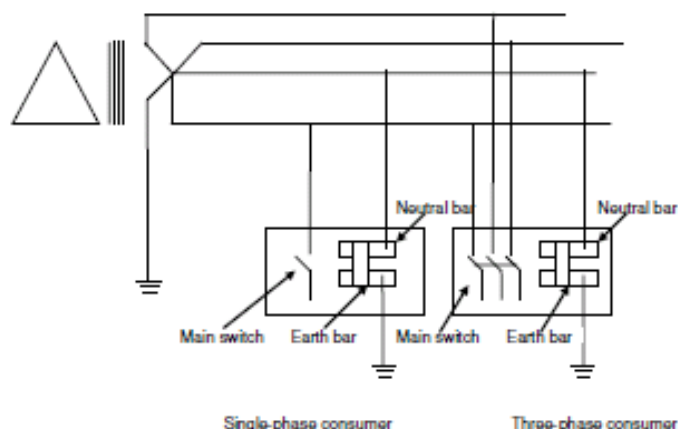

MAXIMUM DEMAND

MAXIMUM DEMAND — SINGLE AND MULTIPLE DOMESTIC ELECTRICAL INSTALLATIONS

1	2	3	4	5
Load Group	Single domestic electrical installation or individual living unit per phase ^a	2 to 5 living units per phase	6 to 20 living units per phase	21 or more living units per phase
		Blocks of living units ^{a,b,c}		
		Loading associated with individual units		
A. Lighting		6 A	5 A + 0.25 A per living unit	0.5 A per living unit
(i) Except as in (ii) and load group H below ^{d,e,f}	3 A for 1 to 20 points + 2 A for each additional 20 points or part thereof	No assessment for the purpose of maximum demand		
(ii) Outdoor lighting exceeding a total of 1000 W ^{f,g}	75% connected load			
B.		10 A + 5 A per living unit	15 A + 3.75 A per living unit	50 A + 1.9 A per living unit
(i) Socket-outlets not exceeding 10 ^{e,h} Permanently connected electrical equipment not exceeding 10 A and not included in other load groups ⁱ	10 A for 1 to 20 points + 5 A for each additional 20 points or part thereof	10 A	10 A	10 A
(ii) Where the electrical installation includes one or more 15 A socket-outlets other than socket-outlets provided to supply electrical equipment set out in groups C,D, E, F, G and L ^{h,j}	15 A	15 A	15 A	15 A
(iii) Where the electrical installation includes one or more 20 A socket-outlets other than socket-outlets provided to supply electrical equipment set out in groups C, D, E, F, G and L ^{h,j}	50% connected load	15 A	2.8 A per living unit	2.8 A per living unit
C. Ranges, cooking appliances, laundry equipment or socket-outlets rated at more than 10 A for the connection thereof ^h	75% connected load	75% connected load	75% connected load	75% connected load
D. Fixed space heating or air-conditioning equipment, saunas or socket-outlets rated at more than 10 A for the connection thereof ^{h,k}	33.3% connected load	6 A per living unit	6 A per living unit	100 A + 0.8 A per living unit
E. Instantaneous water heaters ^l	Full-load current	6 A per living unit	6 A per living unit	100 A + 0.8 A per living unit
F. Storage water heaters ^m	75% of the largest spa, plus 75% of the largest swimming pool, plus 25% of the remainder			
G. Spa and swimming pool heaters				

FOOTNOTES TO MAXIMUM DEMAND TABLE

- a See Clause 1.8.3 for where the maximum demand for consumers mains and submains and final subcircuits respectively may be determined by assessment, measurement or, limitation.
- b For multiphase connections, divide the number of living units by the number of supply phases, e.g. 16 units on a three-phase supply, $16/3 = 6$ units on the heaviest loaded phase (Column 4).
- c Where only a portion of the number of units in a multiple domestic electrical installation is equipped with permanently connected or fixed appliances, such as electric cooking ranges or space heating equipment, the number of appliances in each category is divided over the number of phases, and the maximum demand determined.
- d Lighting track systems shall be regarded as 2 points per metre of track.
- e A socket-outlet installed more than 2.3 m above a floor for the connection of a luminaire may be included as a lighting point in load group A(i) An appliance rated at not more than 150 W, which is permanently connected, or connected by means of a socket-outlet installed more than 2.3 m above a floor, may be included as a lighting point in load group A(i).
- f In the calculation of the connected load, the following ratings shall be assigned to lighting:
- (i) Incandescent lamps 60 W or the actual wattage of the lamp to be installed, whichever is the greater, except that if the design of the luminaire associated with the lampholder permits only lamps of less than 60 W to be inserted in any lampholder, the connected load of that lampholder shall be the wattage of the highest rated lamp which may be accommodated. For multi-lamp luminaires, the load for each lampholder shall be assessed on the above basis.
- (ii) Fluorescent and other discharge lamps Full connected load, i.e. the actual current consumed by the lighting arrangement having regard to auxiliary equipment such as ballasts and capacitors.
- (iii) Lighting tracks 0.5 A/m per phase of track or the actual connected load, whichever is the greater.
- g Flood lighting, swimming pool lighting, tennis court lighting and the like.
- h For the purpose of determining maximum demand, a multiple combination socket-outlet shall be regarded as the same number of points as the number of integral socket-outlets in the combination.
- i Each item of permanently connected electrical equipment not exceeding 10 A may be included in load group B(i) as an additional point.
- j Where an electrical installation contains 15 A or 20 A socket-outlets covered by load group B(ii) or B(iii), the base loading of load group B is increased by 10 A or 15 A respectively; if both 15 A and 20 A socket-outlets are installed, the increase is 15 A.
- k Where an electrical installation includes an air-conditioning system for use in hot weather and a heating system for use in cool weather, only that system which has the greater load shall be taken into account.
- l Instantaneous water heaters including 'quick recovery' heaters having element ratings greater than 100 W/L.
- m Storage type water heaters, including 'quick recovery' heaters not referred to in footnote l.
- n This load group is not applicable to socket-outlets installed in communal areas but connected to the individual living units. Such socket-outlets should be included in load group B.

1. With reference to the relevant standard, calculate the maximum demand of a domestic installation with the following connected load:

• 17 x indoor lighting points	(1-20) 3A	= 3A
• 22 x 10 A socket outlets	(1-20), (21-40) 10A + 5A	= 15A
• 1 x 10 kW electric range	$\frac{10000}{230} = 43.48A$ @ 50%	= 21.74A
• 1 x 2 kW storage-type water	$\frac{2000}{230} = 8.69A$	= 8.69A
Maximum demand	Total	= 48.43A

2. Refer to the relevant standard, and determine the maximum demand of a single domestic installation supplies at 230 V with the following installed loads:

• 15 x 75 W lighting points	(1-20) or $\frac{(15 \times 75)}{230} = 4.89A$	= 4.89A
• 10 x 10 A socket outlets	(1-20) 10A	= 10A
• 1 x 8 kW electric range	$\frac{8000}{230} = 34.78A$ @ 50%	= 17.39A
• 1 x 2 kW controlled load storage water heater	$\frac{2000}{230} = 8.69A$	= 8.69A
Maximum demand	Total	= 40.97A

AS/NZS 3008 1.2 - VOLTDROP

QUESTION 1

It is proposed to use 45 metres of 4 mm² three phase neutral and earth TPS cable to supply 32 amps to a three-phase load. The cable is installed partially in thermal insulation and is operating at an ambient temperature of 35°C and conductor temperature 75°C. The voltage at the switchboard is 400 volts.

- Calculate the voltage drop.
- Does the calculated voltage drop satisfy the requirements of the Electricity Regulations? Give a reason for your answer.
- Calculate the maximum current rating in installed conditions,
- Does the calculated value satisfy the load requirements?
- Is this cable suitable for this installation?
- Give a reason for your answer.

a. Voltdrop

$$VD = \frac{V_c \times L \times A}{1000}$$

$$= \frac{9.71 \times 45 \times 32}{1000} \quad V_c \text{ for } 4\text{mm}^2 = 9.71$$

$$= \underline{13.98 \text{ V}}$$

b. Yes, It's within the 5% of 400 = 20V ... see Regulation 53

c. Installed conditions 4 mm² cable @ 30°C = 25A... info from table 12
 4 mm² cable @ 35°C = 25 x 0.94 = 23.5 A

↑
 Table 27.1

d. No

e. No

f. The cable would be too small for installed conditions because of the load ability. Cables ability is 23.5A and the load is 32A

TABLE 27 (1)
RATING FACTORS FOR VARIATIONS IN AMBIENT TEMPERATURE FOR CABLES IN AIR OR HEATED CONCRETE SLABS AND FOR CABLES BURIED DIRECT IN GROUND OR IN UNDERGROUND WIRING ENCLOSURES—AIR AND CONCRETE SLAB TEMPERATURES

1	2	3	4	5	6	7	8	9	10	11	12	13	14	15	16	17	18	19	20	21	22
Conductor temp °C	Rating factor																				
	Ambient temperature (see Notes 1, 2 & 3) °C																				
	15	20	25	30	35	40	45	50	55	60	65	70	75	80	85	90	100	110	120	130	140
150	1.07	1.05	1.03	1.00	0.98	0.96	0.94	0.91	0.89	0.87	0.85	0.82	0.80	0.77	0.74	0.71	0.66	0.58	0.50	0.41	0.29
110	1.08	1.06	1.03	1.00	0.97	0.93	0.90	0.87	0.83	0.79	0.75	0.71	0.66	0.61	0.56	0.50	0.36	—	—	—	—
90	1.15	1.09	1.05	1.00	0.95	0.91	0.85	0.80	0.74	0.66	0.59	0.52	0.43	0.31	0.17	—	—	—	—	—	—
80	1.17	1.12	1.06	1.00	0.95	0.89	0.82	0.75	0.68	0.59	0.50	0.40	0.24	—	—	—	—	—	—	—	—
75	1.18	1.12	1.06	1.00	0.94	0.88	0.80	0.72	0.63	0.53	0.43	0.32	—	—	—	—	—	—	—	—	—

NOTES:

- For heated concrete slabs, the ambient temperature shall be taken as the operating temperature of the slab.
- The normal usage of high temperature insulant cables is in ambient air temperatures greater than 30°C, see Table 17.
- For cables with a maximum permissible operating temperature above the normal use temperatures specified in Table 2, derating may not be necessary (see Notes to Table 1 for further details).

TABLE 42
THREE-PHASE VOLTAGE DROP AT 50 Hz OF MULTICORE CABLES WITH CIRCULAR COPPER CONDUCTORS

Conductor size mm ²	Three-phase voltage drop at 50 Hz, mV/A.m									
	Conductor temperature, °C									
	45		60		75		90		110	
	Max.	0.8 p.f.	Max.	0.8 p.f.	Max.	0.8 p.f.	Max.	0.8 p.f.	Max.	0.8 p.f.
1	40.3	—	42.5	—	44.7	—	46.8	—	49.7	—
1.5	25.9	—	27.3	—	28.6	—	30.0	—	31.9	—
2.5	14.1	—	14.9	—	15.6	—	16.4	—	17.4	—
4	8.77	—	9.24	—	9.71	—	10.2	—	10.8	—
6	5.86	—	6.18	—	6.49	—	6.80	—	7.22	—
10	3.49	—	3.67	—	3.86	—	4.05	—	4.29	—
16	2.19	—	2.31	—	2.43	—	2.55	—	2.70	—
25	1.39	—	1.47	—	1.54	—	1.61	—	1.71	—
35	1.01	—	1.06	—	1.11	—	1.17	—	1.24	—
50	0.751	—	0.790	—	0.829	—	0.868	—	0.920	—
70	0.530	—	0.556	—	0.583	—	0.609	—	0.645	—
95	0.394	—	0.413	—	0.431	—	0.450	—	0.475	—
120	0.323	—	0.337	—	0.351	—	0.366	—	0.385	—
150	0.274	—	0.285	—	0.296	—	0.307	—	0.322	—
185	0.234	—	0.242	—	0.251	—	0.259	—	0.271	—
240	0.198	0.198	0.204	0.204	0.210	0.210	0.216	0.216	0.224	—
300	0.178	0.175	0.182	0.180	0.186	0.185	0.190	0.189	0.196	0.196
400	0.162	0.157	0.165	0.160	0.168	0.164	0.171	0.167	0.175	0.172
500	0.152	0.143	0.154	0.146	0.156	0.148	0.158	0.151	0.160	0.155

TABLE 12
CURRENT-CARRYING CAPACITIES OF THREE-CORE AND FOUR-CORE 0.6/1 kV
INSULATED AND SHEATHED (INCLUDING NEUTRAL SCREENED) CABLES WITH
OR WITHOUT EARTH CONDUCTOR, ARMoured OR NON-ARMoured CABLES
WITH V-75, V-90, HFI-75-TP OR HFI-90-TP INSULATION (See Note 1)

1	2	3	4	5	6	7	8	9	10	11	12	13	14	15	16	17
Current-carrying capacity, A																
Conductor size	Unenclosed				Enclosed								Buried direct		Underground non-metallic wiring enclosure	
	Spaced		Touching		Non-metallic wiring enclosures in air-round cable		Non-metallic wiring enclosures in air-flat cable		In non-metallic wiring enclosures or unenclosed partially surrounded by thermal insulation		Completely surrounded by thermal insulation					
mm ²	Cu	Al	Cu	Al	Cu	Al	Cu	Al	Cu	Al	Cu	Al	Cu	Al	Cu	Al
1	15	—	14	—	11	9	14	10	11	8	7	—	21	—	17	—
1.5	18	—	17	—	15	11	17	13	14	11	9	—	26	—	21	—
2.5	26	—	25	—	21	16	23	17	19	15	13	—	37	—	29	—
4	35	—	33	—	27	21	30	23	25	19	17	—	48	—	37	—
6	46	—	42	—	35	27	39	30	33	25	22	—	61	—	47	—
10	62	—	58	—	48	38	52	40	44	34	29	—	81	—	63	—
16	82	64	78	60	64	49	68	52	59	46	39	30	106	83	81	64
25	111	86	104	81	90	68	95	72	82	64	52	40	138	107	106	83
35	137	106	125	99	105	80	105	80	96	74	64	49	165	127	127	100
50	165	131	154	120	125	96	125	96	114	90	—	—	198	154	154	121
70	211	165	194	154	160	120	—	—	143	113	—	—	242	187	193	149
95	262	205	245	188	188	143	—	—	171	137	—	—	292	226	231	182
120	302	234	279	222	222	171	—	—	200	160	—	—	330	259	264	209
150	348	268	319	251	257	194	—	—	228	182	—	—	369	292	297	231
185	399	314	371	291	296	222	—	—	262	205	—	—	418	330	341	270
240	467	371	439	348	348	262	—	—	308	245	—	—	484	380	407	319
300	536	428	502	399	—	—	—	—	—	—	—	—	545	429	457	358
400	616	502	570	462	—	—	—	—	—	—	—	—	616	495	528	424
500	707	570	650	524	—	—	—	—	—	—	—	—	682	550	594	479

NOTES:

- 1 Refer to Note 2 of Table 1 for information regarding the use of V-90 insulated cables.
- 2 Refer to Tables 2(1), 2(2), 2(3) and 2(4) for cable configurations deemed to have the same current-carrying capacities as those illustrated.
- 3 Derating factors may apply as follows:
 - (a) The current-carrying capacities apply to single circuits; for grouped cable circuits see Clause 3.5.2 and Tables 22, 24, 25 and 26 for appropriate derating factors.
 - (b) For a single circuit fixed to the underside of a ceiling or similar horizontal surface, see Table 22 for the derating factor to be applied to the current-carrying capacities given in Columns 4 and 5.
 - (c) For a single circuit fixed to unperforated cable tray, see Table 24 for the derating factor to be applied to the current-carrying capacities given in Columns 2 and 3.
 - (d) For ambient temperature and depth of laying factors, see Tables 27 and 28.
- 4 To determine the three-phase voltage drop of these configurations, refer to the appropriate value in Table 42 or Table 45.
- 5 These ratings are based on 30°C ambient air temperature and 15°C ambient soil temperature. For other conditions, see Clause 3.5.3.

QUESTION 2

It is proposed to use 30 metres of 2.5 mm² flat twin and earth TPS cable to supply 21 amps to a single-phase load. The cable is installed partially in thermal insulation and is operating at an ambient temperature of 35°C and conductor temperature 75°C. The voltage at the switchboard is 230 volts.

- Calculate the voltage drop.
- Does the calculated voltage drop satisfy the requirements of the Electricity Regulations? Give a reason for your answer.
- Calculate the maximum current rating in installed conditions,
- Does the calculated value satisfy the load requirements?
- Is this cable suitable for this installation?
- Give a reason for your answer.

a. Voltdrop

$$VD = \frac{V_c \times L \times A}{1000}$$

$$= \frac{15.6 \times 30 \times 21}{1000} \times 1.155 \dots \text{Single phase}$$

$$= \underline{11.35 \text{ V}}$$

b. Yes, It's within the 5% of 230 = 11.5V ...

c. Installed conditions 2.5mm² cable @ 30°C = 21A ... Info from table 9
 2.5mm² cable @ 35°C = 21 x 0.94 = 19.78A

d. No

e. No

f. The cable would be too small for installed conditions because of the load ability.
 Cables ability is 19.78A and the load is 21A

Table 27.1

TABLE 27 (1)
RATING FACTORS FOR VARIATIONS IN AMBIENT TEMPERATURE FOR CABLES IN AIR OR HEATED CONCRETE SLABS AND FOR CABLES BURIED DIRECT IN GROUND OR IN UNDERGROUND WIRING ENCLOSURES—AIR AND CONCRETE SLAB TEMPERATURES

1	2	3	4	5	6	7	8	9	10	11	12	13	14	15	16	17	18	19	20	21	22
Conductor temp °C	Rating factor																				
	Ambient temperature (see Notes 1, 2 & 3) °C																				
	15	20	25	30	35	40	45	50	55	60	65	70	75	80	85	90	100	110	120	130	140
150	1.07	1.05	1.03	1.00	0.98	0.96	0.94	0.91	0.89	0.87	0.85	0.82	0.80	0.77	0.74	0.71	0.66	0.58	0.50	0.41	0.29
110	1.08	1.06	1.03	1.00	0.97	0.93	0.90	0.87	0.83	0.79	0.75	0.71	0.66	0.61	0.56	0.50	0.36	—	—	—	—
90	1.15	1.09	1.05	1.00	0.95	0.91	0.85	0.80	0.74	0.66	0.59	0.52	0.43	0.31	0.17	—	—	—	—	—	—
80	1.17	1.12	1.06	1.00	0.95	0.89	0.82	0.75	0.68	0.59	0.50	0.40	0.24	—	—	—	—	—	—	—	—
75	1.18	1.12	1.06	1.00	0.94	0.88	0.80	0.72	0.63	0.53	0.43	0.32	—	—	—	—	—	—	—	—	—









NOTES:

- 1 For heated concrete slabs, the ambient temperature shall be taken as the operating temperature of the slab.
- 2 The normal usage of high temperature insulant cables is in ambient air temperatures greater than 30°C, see Table 17.
- 3 For cables with a maximum permissible operating temperature above the normal use temperatures specified in Table 2, derating may not be necessary (see Notes to Table 1 for further details).

TABLE 42
THREE-PHASE VOLTAGE DROP AT 50 Hz OF MULTICORE CABLES WITH CIRCULAR COPPER CONDUCTORS

Conductor size mm ²	Three-phase voltage drop at 50 Hz, mV/A.m									
	Conductor temperature, °C									
	45		60		75		90		110	
	Max.	0.8 p.f.	Max.	0.8 p.f.	Max.	0.8 p.f.	Max.	0.8 p.f.	Max.	0.8 p.f.
1	40.3	—	42.5	—	44.7	—	46.8	—	49.7	—
1.5	25.9	—	27.3	—	28.6	—	30.0	—	31.9	—
2.5	14.1	—	14.9	—	15.6	—	16.4	—	17.4	—
4	8.77	—	9.24	—	9.71	—	10.2	—	10.8	—
6	5.86	—	6.18	—	6.49	—	6.80	—	7.22	—
10	3.49	—	3.67	—	3.86	—	4.05	—	4.29	—
16	2.19	—	2.31	—	2.43	—	2.55	—	2.70	—
25	1.39	—	1.47	—	1.54	—	1.61	—	1.71	—
35	1.01	—	1.06	—	1.11	—	1.17	—	1.24	—
50	0.751	—	0.790	—	0.829	—	0.868	—	0.920	—
70	0.530	—	0.556	—	0.583	—	0.609	—	0.645	—
95	0.394	—	0.413	—	0.431	—	0.450	—	0.475	—
120	0.323	—	0.337	—	0.351	—	0.366	—	0.385	—
150	0.274	—	0.285	—	0.296	—	0.307	—	0.322	—
185	0.234	—	0.242	—	0.251	—	0.259	—	0.271	—
240	0.198	0.198	0.204	0.204	0.210	0.210	0.216	0.216	0.224	—
300	0.178	0.175	0.182	0.180	0.186	0.185	0.190	0.189	0.196	0.196
400	0.162	0.157	0.165	0.160	0.168	0.164	0.171	0.167	0.175	0.172
500	0.152	0.143	0.154	0.146	0.156	0.148	0.158	0.151	0.160	0.155

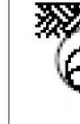
TABLE 9
CURRENT-CARRYING CAPACITIES OF TWO-CORE 0.6/1 kV INSULATED AND SHEATHED (INCLUDING NEUTRAL SCREENED) CABLES WITH OR WITHOUT EARTH CONDUCTOR, ARMoured OR NON-ARMoured CABLES WITH V-75, V-90, HFI-75-TP OR HFI-90-TP INSULATION (See Note 1)

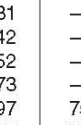
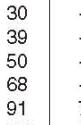
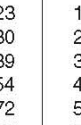
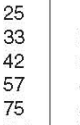
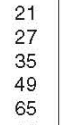
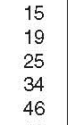
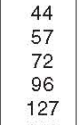
1	2	3	4	5	6	7	8	9	10	11	12	13	14	15	16	17	
Current-carrying capacity, A																	
Con- ductor size	Unenclosed				Enclosed								Buried direct		Underground non-metallic wiring enclosure		
	Spaced		Touching		Non- metallic wiring enclosures in air-round cable		Non-metallic wiring enclosures in air-flat cable		In non-metallic wiring enclosures or unenclosed partially surrounded by thermal insulation		Completely surrounded by thermal insulation						
																	
mm ²	Cu	Al	Cu	Al	Cu	Al	Cu	Al	Cu	Al	Cu	Al	Cu	Al	Cu	Al	
1	17	—	16	—	13	10	15	11	11	9	8	—	24	—	19	—	
1.5	22	—	21	—	16	13	19	15	15	11	10	—	31	—	24	—	
2.5	31	—	30	—	23	17	25	19	21	16	15	—	44	—	34	—	
4	42	—	39	—	30	23	33	25	27	22	19	—	57	—	44	—	
6	52	—	50	—	39	30	42	32	35	27	25	—	72	—	56	—	
10	73	—	68	—	54	41	57	43	49	38	34	—	96	—	75	—	
16	97	75	91	71	72	55	75	57	65	50	46	35	127	97	97	75	
25	131	100	120	95	100	76	101	76	90	71	60	47	160	127	127	98	
35	160	125	148	114	120	89	120	89	105	82	74	58	198	154	154	121	
50	194	148	182	143	143	107	143	107	125	99	—	—	231	182	182	143	
70	245	188	228	177	177	137	—	—	160	125	—	—	286	220	226	176	
95	302	234	285	217	217	165	—	—	188	148	—	—	341	264	275	215	
120	348	274	331	257	257	194	—	—	222	177	—	—	391	303	319	248	
150	399	308	376	291	291	217	—	—	251	200	—	—	440	341	358	275	
185	462	359	428	336	336	251	—	—	291	228	—	—	495	385	407	319	
240	542	428	507	399	393	296	—	—	342	274	—	—	572	446	473	369	
300	627	490	581	456	456	342	—	—	393	314	—	—	649	506	545	429	
400	718	570	673	530	530	399	—	—	462	365	—	—	726	583	616	490	
500	821	661	764	616	707	564	—	—	564	450	—	—	814	660	715	572	

NOTES:

- Refer to Note 2 of Table 1 for information regarding the use of V-90 insulated cables.
- Refer to Tables 2(1), 2(2), 2(3) and 2(4) for cable configurations deemed to have the same current-carrying capacities as those illustrated.
- Derating factors may apply as follows:
 - The current-carrying capacities apply to single circuits; for grouped cable circuits see Clause 3.5.2 and Tables 22, 23, 25 and 26 for appropriate derating factors.
 - For a single circuit fixed to the underside of a ceiling or similar horizontal surface, see Table 22 for the derating factor to be applied to the current-carrying capacities given in Columns 4 and 5.
 - For a single circuit fixed to unperforated cable tray, see Table 24 for the derating factor to be applied to the current-carrying capacities given in Columns 2 and 3.
 - For ambient temperature and depth of laying factors, see Tables 27 and 28.
- To calculate the single-phase voltage drop of these configurations, multiply the appropriate three-phase voltage drop value in Table 42 or Table 45 by 1.155.
- These ratings are based on 30°C ambient air temperature and 15°C ambient soil temperature. For other conditions, see Clause 3.5.3.

Switchboards and Isolation Devices - Possible Questions

1 State one technical reason for earthing the neutral in the MEN system of supply. (N02)

Any one:

- **To provide a very low resistance circuit/path to the distribution transformer via the parallel paths of the neutral and earth conductors.**
- **To ensure a high fault current flow and rapid operation of the circuit protection in the event of an earth fault.**
- **To ensure the maximum voltage to earth is 230V.**
- **To keep the voltage between neutral and earth to zero.**
- **If the MSN fails (goes O/C), the installation neutral potential is held to earth potential.**

2 MEN switchboards are not deemed to be safe unless they satisfy a number of criteria: One criterion is that MEN switchboards need to be connected to an earth electrode. (N02)

Describe:

a) How this is achieved.

By use of an earthing lead.

b) Where and how the connection at the switchboard should be made.

**Connected to the earth continuity busbar. By being secured by a minimum of 2 screws.
OR: By a separate cable lug to stud with nut and locknut.**

c) The means of identifying both the electrode and switchboard connections.

Labelled at both the electrode and the switchboard so it is identified as the earthing lead.

d) One other important MEN busbars related connection at the switchboard that is required in order for the board to comply.

Must have a removable link between the earth bar and the neutral of the supply.

3 Define the term main switchboard. (J02)

The switchboard used by the consumer to provide the greatest degree of control of the supply of electricity to that installation.

4 List two factors that must be considered when siting a switchboard. (J02)

Any two:

- **Environment**
- **Mechanical conditions**
- **Load distribution**
- **Prospective short circuit currents**
- **Protection against spread of fire**
- **Access.**

5 A distribution switchboard does not have an earthing lead, nor can it be supplied from a linked-busbar switchboard. How then is an earth connection provided for the earth continuity busbar? (J02)

They have an ECC between the earth bar on the distribution board and the earth bar at the MEN board from where it is supplied.

6 Give a reason why unwanted transient voltages may occur in standard MEN supply lines. (N01)

Switching of inductive loads, large faults, lightning or similar.

7 Define the term switchgear. (N01)

Fittings for controlling the distribution of electricity, or for controlling or protecting electrical circuits and appliances.

8 When installing switchboards, there are a number of specific physical requirements to ensure they are electrically safe. List FOUR of these. (J01)

Any FOUR:

- **Constructed of fire resistant materials.**
- **Accessible.**
- **Contains suitable isolation requirements.**
- **Suitably labelled.**
- **Constructed of durable materials or similar.**

9 Explain why steel gland plates that are used to support single core AC cable glands must have slots cut between the gland holes. (J01)

Single core cables have a magnetic field around them, which will induce an emf into the gland plate causing heating. The slots increase the gland plate resistance reducing eddy currents and therefore heating.

10 List FOUR locations where switchboards must either not be located or require special construction features. (J01)

Any FOUR:

- **Stairways or stairwell.**
- **Damp situations.**
- **Sauna rooms.**
- **Hazardous areas.**
- **Above cooking appliances.**
- **Cupboard containing fire hose reel**

11

a) Sketch and label a simple diagram to represent an MEN distribution system showing: (N01)

- A delta-star connected 11 kV/400 V supply transformer including output lines
- A single-phase consumer including main switch, and neutral and earth bar connections
- A three phase consumer including main switch, neutral and earth bar connections
- All earthing arrangements.

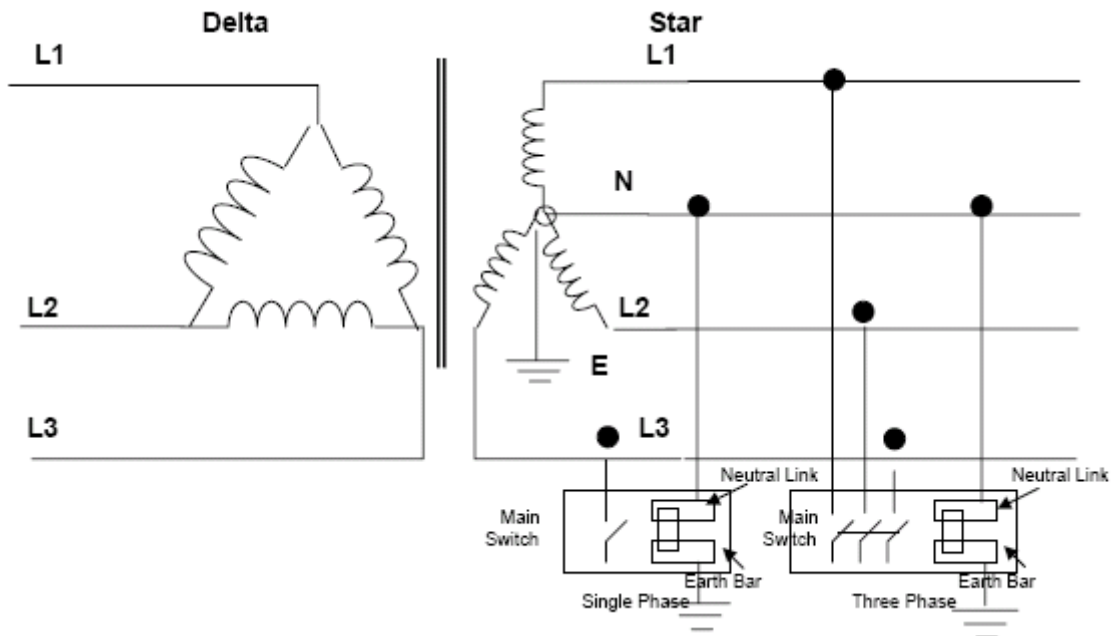

b) List two advantages of a three phase MEN system

Any two:

- **Low overall fault impedance.**
- **Limit of 230V shock hazard to earth.**
- **Fewer conductors (no earth required for mains and distribution)**

c) Explain the meaning of the term electrically safe. (N01)

Everything electrical must be installed, used, etc, so as not to cause harm to people or damage to property.

12 What type of switchboard must be used as the main switchboard in an electrical installation supplied from a standard low voltage supply? (J01)

An MEN switchboard.

13 Sketch and label a diagram to show how a three phase, 400V distribution switchboard in an engineering workshop can be supplied from a RCD on a MEN main switchboard. (N00)

Provide the following in your diagram:

- MEN switchboard, including mains in, main earth, N and E bars, main switch, circuit protection (fuses) and an RCD (block only).
- Cable supplying the distribution switchboard, including the number of cores.
- Distribution switchboard, including N and E bars, main switch, subcircuit protection (fuses), and subcircuit wiring to a single phase and a three phase circuit.

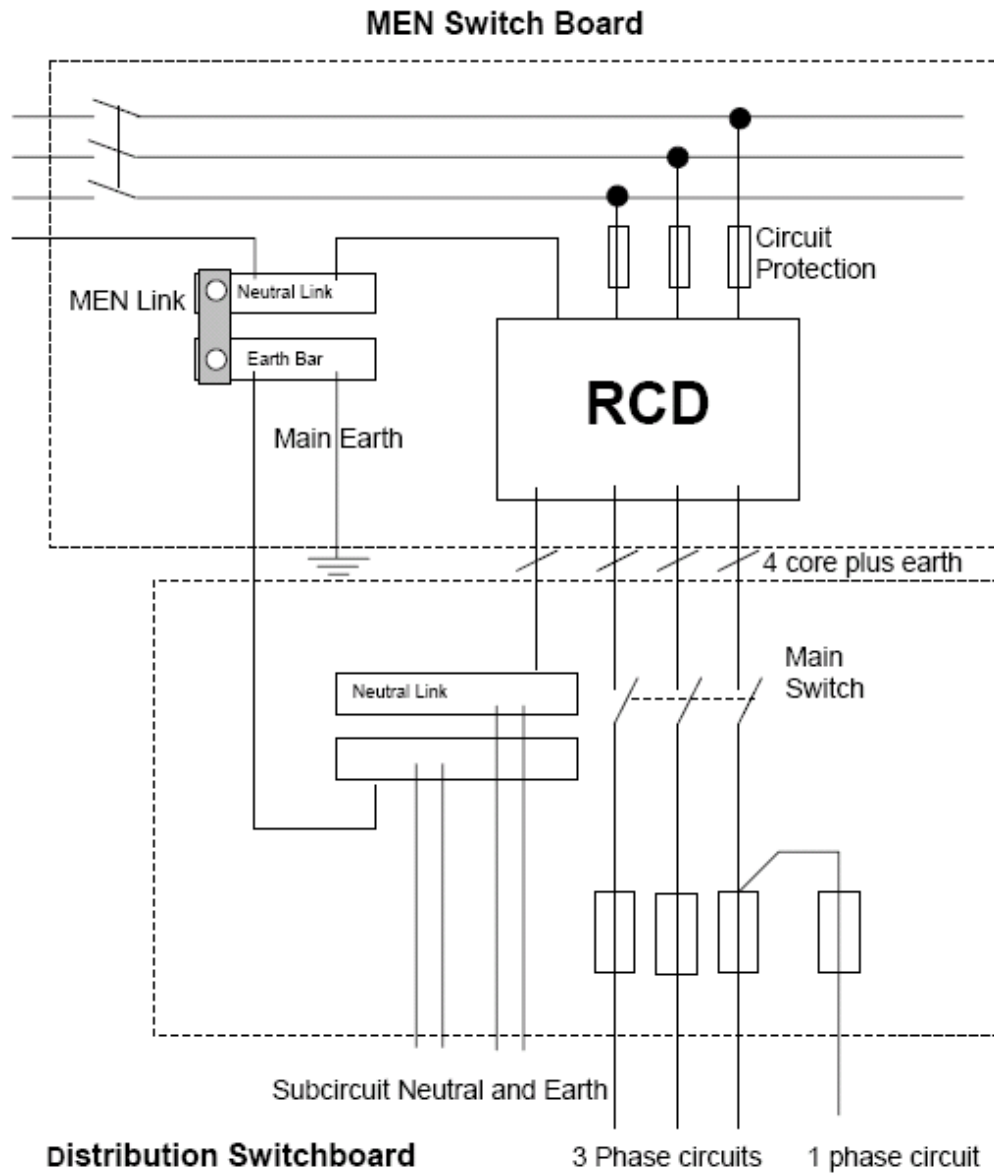

THEORY

14. The two figures on the following page represent a three-phase MEN switchboard and a three-phase distribution switchboard in a three-phase electrical installation. The supply comes into the MEN switchboard and the three-phase distribution switchboard is supplied from the MEN switchboard. The distribution switchboard is protected by an RCBO. On the figures, draw and label the circuit diagram that shows:

- The supply to the MEN switchboard.
- The wiring between the MEN switchboard and the distribution switchboard.
- The distribution board protection on the MEN switchboard.
- The main switches on both boards.
- The earthing and neutral arrangements on both boards
- The neutral and earthing fittings on both boards (bars, link, electrode, tags). There are other final subcircuits, MCBs, RCDs on both switchboards that do not need to be drawn. (ET32)

(10 marks)

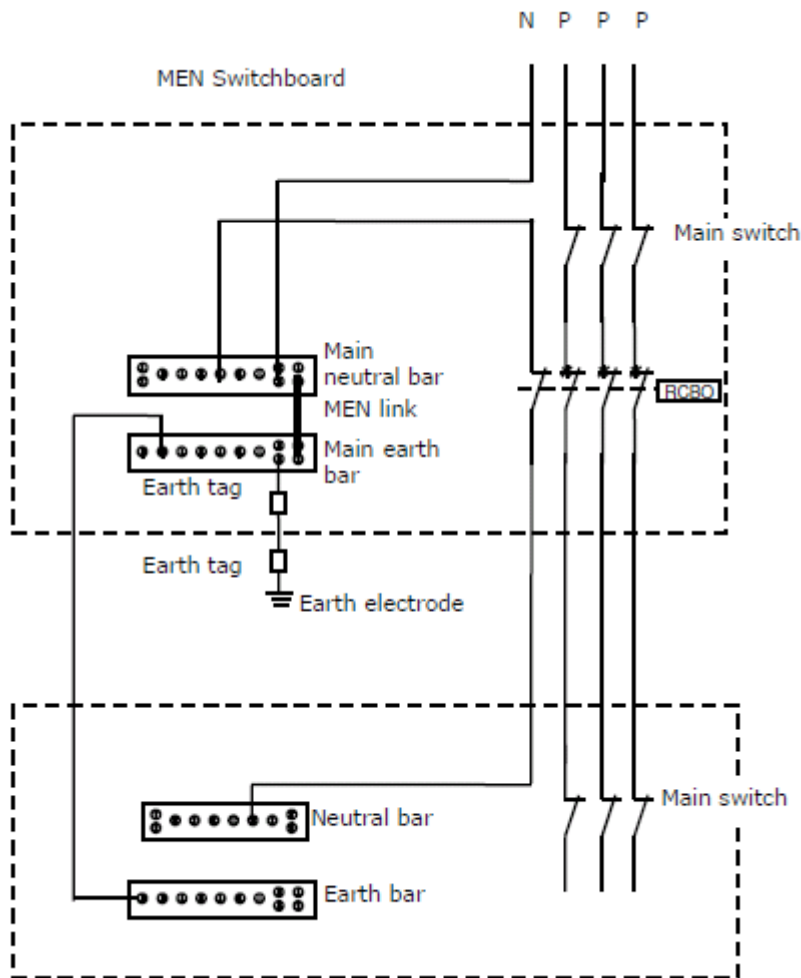

Possible Questions

- 1 What is meant by the term 'Testing' as applied to electrical work?

Carrying out a checking or testing procedures with or without test instruments in order to prove that it's safe and has been wired correctly.

- 2 When using a suitable test instrument to check for isolation of a circuit the prove test prove procedures is recommended.

What are the three checks that the procedure is intended to verify?

**Prove that your meter is working (against a known source).
Test the circuit required and isolate.
Prove that the meter is still working (using the original source).**

- 3 Briefly explain why, when required to carry out an insulation resistance test on the internal wiring of a single phase electrical appliance, an ohmmeter or a multimeter should not be used.

A multimeter has internal batteries which give out only very small voltages (1.5 to 9v), which is not sufficient to stress the insulation for electrical strength. Insulation resistance is determined by being stressed to at least 500V DC.

4

- i) List the four tests/checks required to ensure electrical safety when a fixed wired, three- phase, 400V water pump and sub-circuit wiring have been installed. (Nov 99)
- **Earth Continuity Test (including Bonding)**
 - **Polarity**
 - **Visual**
 - **Insulation Resistance test**
- ii) Describe in detail how **each** of the tests/checks in (a) should be carried out. Include in your answer, where applicable, the type of meter used and any minimum or maximum values that may apply

Earth Continuity Test

Test between all exposed metal and the earth at the switchboard

Meter: Low ohmmeter or multimeter on a low ohms scale

Maximum reading for bonding: 0.5Ω

Insulation resistance test

Test between al conductors and conductors to earth

Meter: Insulation resistance tester – 500 DC

Minimum reading: 1 MΩ

Polarity test

Check visually or with instruments that all phase conductors are switched, and that all conductors go to the right terminals.

Visual Test

Correct colour code

Covers are on

Connections are tight

Basic insulation not exposed

No access to live parts

Any other reasonable answers

5 A single phase, 230V, 50 Hz, 6 kW, deep fryer has been repaired by you. The fryer has mineral-insulated, metal sheathed elements and is connected to the supply by a 30A flexible cord and three pin plug. List the **four** test/checks that are required to ensure electrical safety before the fryer is returned to service. (11/00)

- **Earth Continuity Test (including Bonding)**
- **Polarity**
- **Visual**
- **Insulation Resistance test**

i) Describe in detail how **each** of the tests/checks in (a) should be carried out. Include in your answer, where applicable, the type of meter used and any minimum or maximum values that may apply

Earth Continuity Test

Test between the earth pin on the plug and all exposed metal on the appliance.

Meter: Low ohmmeter or multimeter on a low ohms scale

Maximum reading for bonding: 1Ω

Insulation resistance test

Short phase and neutral together and test to earth.

Meter: Insulation resistance tester – 500 DC

Minimum reading: 10000 M Ω

Polarity test

Check visually or with instruments that all phase conductors are correctly connected.

All phase conductors must be switched.

6 A three phase socket outlet including sub-circuit wiring and switchboard work has been installed in a bakery to supply a food mixer. (Jun 2001)

a) Which Standard should the testing of this installation comply with to ensure electrical safety?

ASNZS 3000 section 8

b) List the **four** tests/checks required to ensure that the installation is electrically safe.

1. **Earth Continuity Test (including Bonding)**
2. **Polarity**
3. **Visual**
4. **Insulation Resistance test**

7 With respect to the electrical testing of an installation:

a) Give two reasons why polarity testing is carried out.

Polarity testing is necessary to ensure that no shock hazard arises from the incorrect connection of active, neutral and earthing conductors. This testing is to prevent-

- **The transposition of active and neutral and conductors of the consumer's mains or sub-mains resulting in the electrical installation earthing systems becoming energized; and**
- **Combinations of incorrect active, neutral and earthing conductor connections resulting in the exposed conductive parts of the electrical installation becoming energized; and**
- **The connection of switches in neutral conductors, resulting in parts of appliance, such as heating elements and lamp holders, remaining energized when the switches are in the "off" position.**

b) Between which conductors are insulation resistance tests to be made?

Between all phases
Between phases and neutral
Between Phases and earth
Between neutral and earth

c) State the minimum allowable value of insulation resistance for an installation.

1 M ohm

- d) With respect to the earthing lead and any exposed metal in the installation, described the two main conditions that earth continuity testing is carried out to prove.
1. **The connection of the earthing lead is continuous and $\leq 0.5\Omega$**
 2. **The connection between any point required to be earthed and the earth bar is continuous (and $\leq 0.5\Omega$)**
- e) What is the maximum allowable value of resistance when carrying out an earth continuity test on a fixed wired appliance?
- Low enough to operate the protection device with in the correct time limit**
- f) State the maximum allowable resistance between bonded exposed metal and the earth electrode?
- $\leq 0.5\Omega$**
- g) State the minimum test voltage for an insulation resistance test to be carried out on a circuit that has a voltage up to 250v ac between phase and earth.
- 500volts DC**
- h) State the reason why some electrical fittings, such as light dimmers, carry a warning against insulation resistance testing between phase and neutral. (N99)

The components will not withstand the voltage of the tester.

- 8 a) (i) State ONE reason for carrying out an earth fault loop impedance test on a single-phase socket outlet circuit.

Any ONE of:

- **ensures adequate earthing connections**
- **to test the impedance of the fault circuit**
- **determines if the protection will operate within the required time.**

- (ii) Describe how the earth fault loop impedance tester is connected

Any ONE of:

- **a single-phase plug from the tester is plugged into a socket outlet.**
- **Phase is connected to phase, neutral is connected to neutral and earth is connected to earth.**
- **Phase is connected to phase and earth is connected to earth.**

- (b)(i) State the reason for carrying out an RCD test on a single-phase portable RCD.

- **To prove the RCD operates within the specified current and time limits.**

- (ii) Describe how the RCD tester is connected.

- **Plug the RCD into a socket outlet and the RCD tester into the RCD being tested.**

9. Carefully read the entire question before answering parts (a) and (b). (ET21)

You have been requested to commission a new single-phase electric hot water cylinder in a small factory. The cylinder element is an MIMS type. The connection is to be made via a new flexible cord. The cylinder circuit is supplied by an HRC fuse on a three-phase switchboard and a lockable isolating switch is located adjacent to the cylinder. The cylinder connects directly via a flexible cord to the isolating switch. Another electrician has disconnected the old cylinder from the isolating switch. The isolating switch is not locked nor is it tagged.

(a) Describe the TWO tests you will make using test instruments to ensure that the new cylinder is safe to connect to the power supply. The tests are to be carried out after you have connected the flexible cord to the cylinder, but before you connect it to the isolating switch. Include in your description for each test:

- The type of instrument used
- The test voltage applied - if applicable.
- The expected test result
- Whether the test result is a minimum or maximum value

(6 marks)

Test 1

An insulation resistance test:

- **Use an insulation resistance tester.**
- **A 500V d.c. test voltage**
- **Test between phase and earth and neutral and earth.**
- **An expected test result of 10,000 ohms or 0.01 Mohms.**
- **The test result being a minimum value.**

Test 2

A protective earthing conductor test.

- **Use a meter that can accurately read values of 1 ohm or less.**
- **Test between the PEC conductor of the flexible cord and the case of the cylinder.**
- **Expected test result of 1 ohm**
- **The test result being a maximum value.**

(b) Describe the steps that you will take to ensure your own safety prior to connecting the new cylinder to the isolating switch.

(4 marks)

- **Identify the correct fuse on the switchboard.**
- **Attach a Danger tag to the circuit.**
- **Remove the isolator cover and test for voltage at the supply side of the isolator using the Prove-test-prove method.**

10. A 20A MCB protects a circuit consisting of multiple plug sockets supplying various electrical appliances in an office. The MCB has tripped. When the MCB is reset, it trips again when the supply is restored to the circuit. You have established that the MCB is not faulty and is correctly rated for the circuit. (ET21)

(a) State the THREE possible causes of the MCB tripping for the second time.

(3 marks)

- **Overload caused by too many appliances in use.**
- **A faulty appliance.**
- **A faulty circuit.**

(b) For each of the possible causes you have stated in (a), state:

- What action you would take to establish that this is the cause.
- The action you would take to fix the problem.

(i) Possible cause No. 1

(2 marks)

- **Overload caused by too many appliances in use.**

Action taken to establish that this is the cause.

- **Total up the rating of the appliances.**

Remedial action taken or recommended

- **Use fewer appliances**

(ii) Possible cause No. 2

(2 marks)

- **A faulty appliance**

Action taken to establish that this is the cause.

- **Carry out an insulation resistance test of each appliance in turn to establish which is faulty.**

Remedial action taken or recommended

- **Repair the faulty appliance.**

(iii) Possible cause No. 3

(3 marks)

- **A faulty circuit**

Action taken to establish that this is the cause.

- **Disconnect circuit at switchboard.**
- **Carry out an insulation resistance test of the circuit to establish fault.**

Remedial action taken or recommended

- **Repair or replace the faulty circuit appliance.**

11. (a) The figure below represents a new low voltage single-phase supply to a domestic installation. The installation is live. (ET24)

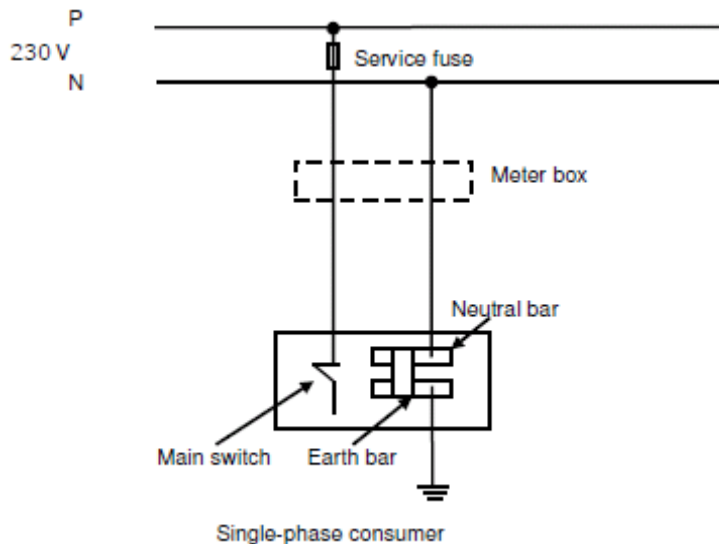

State THREE hazards that will occur if the phase and neutral are transposed.

(3 marks)

Any THREE of:

- Any metal not normally live could be live at up to 230V.
- If the earth fault path is of high impedance the main fuse may not blow.
- Shock hazard could occur.
- Fire hazard could occur.
- Parts of an electrical appliance could be live with the control switch in the “OFF” position.
- Parts of the installation could be live with the main switch in the “OFF” position.
- The earth bar/neutral bar/MEN link could be live at up to 230V.
- The neutral is being switched.

(b) From the figure in (a) above:

(i) Describe how you would carry out an instrument test to establish whether a phase/neutral transposition has taken place. Include in your description the type of instrument and equipment used.

(3 marks)

- Use a voltmeter, remote earth and trailing lead.
- Take a voltage test between the supply side of the main switch and the remote earth.
- Take a voltage test between the earth/neutral bar and the remote earth.

(ii) State the expected instrument readings when a transposition has taken place.

(2 marks)

- The reading at the main switch should be 0V.
- The reading at the neutral/earth bar should be about 230V.

(c) An existing low voltage single phase electrical installation has been operating satisfactorily for the 10 years since it was new. No electrical work has been carried out on the installation or on the surrounding distribution network since the house was built. The occupants have begun to receive electric shocks off their washing machine you have been called to investigate and make repairs for some No transposition has occurred to the mains of the house.

State TWO likely causes of the problem.

(2 marks)

Any TWO of:

- **The main neutral in the house is open-circuited (or high resistance)**
- **The main distribution neutral is open-circuited (or high resistance)**
- **The earth**

12. (a) The figure below represents an earth fault loop impedance test on a single phase socket outlet in a low voltage electrical installation. Commencing at the earth fault loop impedance tester, describe the circuit that is being tested by the tester. (ET28)

(7 marks)

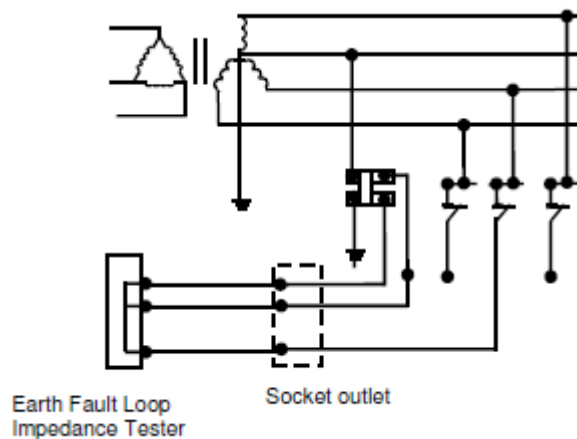

The elements of the fault loop being tested are:

- **The socket outlet.**
- **The final subcircuit earth conductor**
- **The MEN connection**
- **The consumers main neutral.**
- **The distribution neutral.**
- **The distribution transformer.**
- **The distribution active (phase) conductor.**
- **The main switch.**
- **The switchboard cables.**
- **The protective device.**
- **The final subcircuit active conductor..**

(b) State TWO uses for the information gained from an earth fault loop impedance test carried out in (a) above.

(2 marks)

Any TWO of:

- **Determine the prospective short circuit current at the point in an installation.**
- **Determine that the correct type and current rating of circuit protection is installed.**
- **Determine the fault loop impedance of the circuit.**

(c) Why is the earth fault loop path between the earth and neutral bars and MEN link and the star point via the main neutral considered more important than the path between the earth and neutral bars and MEN link and the star point via the mass of earth

(1 mark)

- **It is considered to be the path with the lowest impedance.**

Transformers – Possible Questions

1 What is a typical secondary voltage for a voltage transformer used for high voltage protection? (J03)

110V or 63.5V

2 Why are auto transformers not to be used to supply extra-low voltage electric toys? (J03)

Because an autotransformer can fail or can be incorrectly connected in such a way as to have the primary voltage across the secondary

3 A 150 kVA three phase, delta-star connected transformer has a turns ratio of 47.8 to 1. The primary is connected to an 11kV three phase supply and the transformer is fully loaded. (J03)

a) Sketch and label a circuit diagram of the circuit.

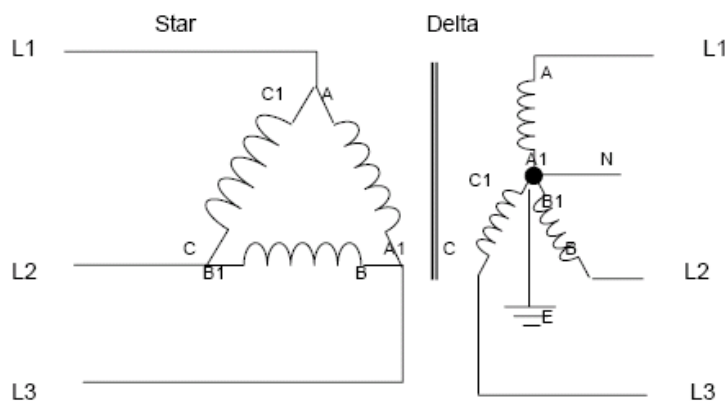

b) Calculate the secondary phase voltage.

$$\frac{N_s}{N_p} = \frac{V_s}{V_p}$$

$$V_s = \frac{N_s \times V_p}{N_p}$$

$$V_s = \frac{1 \times 1000}{47.8}$$

$$V_s = 230V \dots\dots V_p$$

c) Calculate the secondary line voltage.

$$V_L = V_{ph} \times \sqrt{3}$$

$$= 230 \times \sqrt{3}$$

$$= 398.6V$$

d) Calculate the primary line current.

$$S = V_L \times I_L \times \sqrt{3}$$

$$I_L = \frac{S}{V_L \times \sqrt{3}}$$

$$I_L = \frac{150000}{11000 \times \sqrt{3}}$$

$$I_L = 7.87A$$

e) Calculate the secondary line current.

$$S = V_L \times I_L \times \sqrt{3}$$

$$I_L = \frac{S}{V_L \times \sqrt{3}}$$

$$I_L = \frac{150000}{398.6 \times \sqrt{3}}$$

$$I_L = 217.27A$$

4 A special load requires three separate double wound transformers, each having 250 turns on one winding and 2500 turns on the other winding. These transformers are supplied from a 400V three phase three wire supply. (N02)

- a) Use a diagram to show a method of connection to obtain 69.28 V across lines in a four wire system. Indicate on your diagram the secondary line to line and line to neutral voltages.

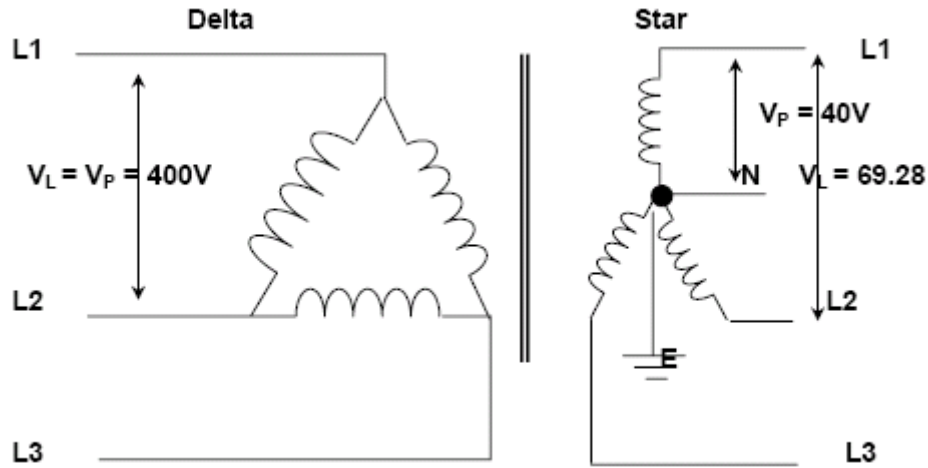

b)

- i) How is the output voltage of a large power transformer maintained as the load changes? (J02)

$$\frac{N_s}{N_p} = \frac{V_s}{V_p}$$

$$V_s = \frac{N_s \times V_p}{N_p}$$

$$V_s = \frac{400 \times 250}{2500}$$

$$V_s = 40 \text{ Volts..... Phase voltage}$$

- ii) Secondary phase voltage is 40V, and to obtain a 4 wire system, a Star connection is required.

$$\begin{aligned} V_{line} &= V_{phase} \times \sqrt{3} \\ &= 40 \times \sqrt{3} \\ &= 69.28V \end{aligned}$$

5

a) Sketch and label a circuit diagram to show how a voltage transformer and a current transformer can be connected to meters in a single phase circuit to measure the current, voltage and power. Include in your diagram the following components. (J02)

- Current transformer
- Voltage transformer
- Ammeter
- Voltmeter
- Wattmeter
- Load
- Metering protection
- Earthing

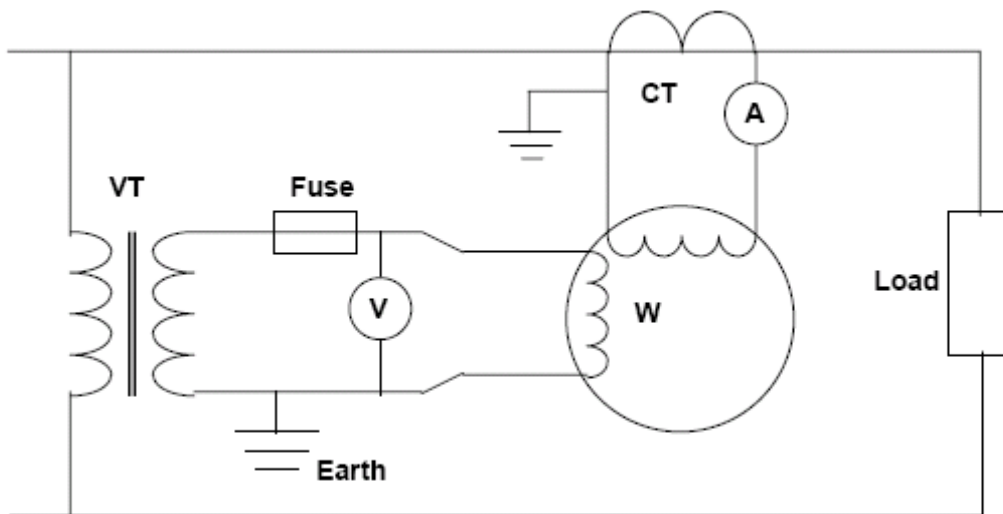

b) The ammeter in the circuit in (a) is to be removed for calibration.

i) State the precautions that must be taken before removing the ammeter from a live circuit.

The terminals must not be open circuited at any time.

ii) State TWO hazards that may exist if this precaution is not taken.

**Damage to CT windings
Shock hazard to persons**

6 How is the voltage regulation of a power transformer achieved with changing loads. (N01)

Tapchangers

7 What type of winding arrangement is most likely in a three phase power transformer that has three connections to its primary and four connections to its secondary. (N01)

Delta - Star

8

- a) Sketch and label a circuit diagram to show how a current operated relay and current transformer (CT) can be connected in a circuit to provide protection against excess current. Include in your diagram the following components: (N01)

- CT
- Load
- Relay contacts
- Relay coil

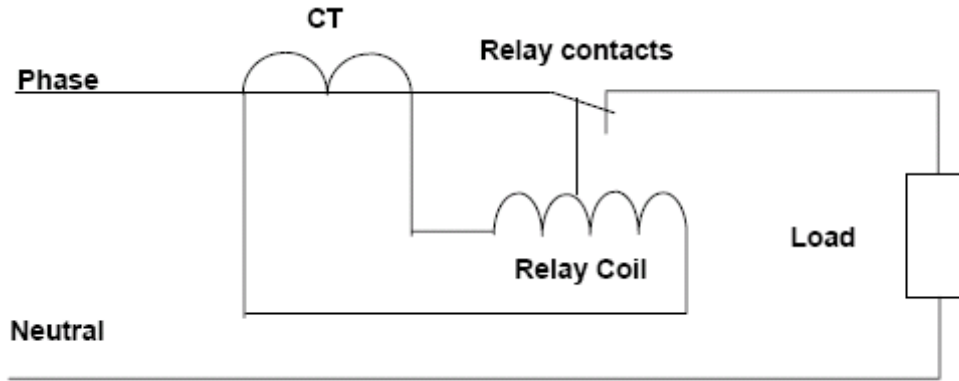

- b) Explain why there are no fuses on the secondary of the CT in (a).

If open circuited, high voltages may be present causing hazard of electric shock and possible

- c) State two common secondary current ratings used for CTs.

- i. 1A
- ii. 5A

- d) Sketch and label a circuit diagram to show how a voltage transformer (VT) can be connected in a circuit to supply a reduced voltage to an indicating voltmeter.

Include in your diagram the following components:

- VT
- Load
- Meter
- Meter protection.

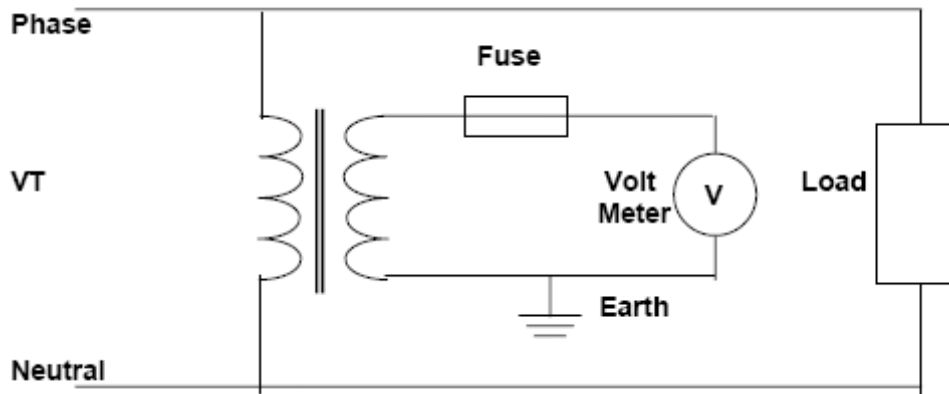

- e) State the common secondary voltage rating of voltage transformers when supplied at their full primary voltage.

110V (63.5V)

THEORY

- 9 What precaution must be taken before disconnecting metering from a CT in a live circuit that cannot be isolated? (J01)

The CT secondary must be short circuited.

- 10 List TWO practical construction methods of reducing the iron losses in a power transformer. (J01)

Use transformer steel and lamination of the iron core.

11

- a) A 7 kVA, single phase, 400V spot welder has three turns on the secondary and an open circuit voltage of 3V across the welding tips. (J01)

- i) Calculate each of the following:

- (1) the number of turns on the primary winding

$$\frac{N_s}{N_p} = \frac{V_s}{V_p}$$

$$N_p = \frac{N_s \times V_p}{V_s}$$

$$N_p = \frac{3 \times 400}{3}$$

$$N_p = 400 \text{ Turns}$$

- (2) the full load primary current when welding

$$S = V \times I$$

$$I_p = \frac{S}{V_p}$$

$$I_p = \frac{7000}{400}$$

$$I_p = 17.5A$$

- (3) the maximum welding current

$$S = V \times I$$

$$I_p = \frac{S}{V_p}$$

$$I_p = \frac{7000}{3}$$

$$I_p = 2333A$$

- ii) the welder winding resistances are as follows:

- Primary winding 0.8 ohms.
- Secondary winding 0.0005 ohms.

Explain in detail why Ohms law cannot be used to calculate the current flow in each winding using this information and the voltage across the winding.

Because the main current limiting factor in a transformer is inductive reactance not resistance.

- b) Describe a typical method for cooling a 100 MVA power transformer.

Oil circulated through external radiators by pumps and cooled in radiators by fans

12 Why are the low voltage windings in large power transformers placed closest to the core? (N00)

They are easier to insulate from the iron circuit than the high voltage windings.

13 Define the term voltage regulation as applied to a transformer. (N00)

The difference between no load voltage and the full load voltage expressed as a percentage of the no load voltage.

14 Define the term burden as applied to a current transformer. (N00)

The maximum load the transformer can supply.

15

a) A transformer supplying an electric toy with a current of 2A has a step down ratio of 20:1. Its primary winding consists of 2000 turns. Calculate each of the following (show all workings). (N00)

i) number of secondary turns

$$\frac{N_s}{N_p} = \frac{1}{20}$$

$$N_s = \frac{N_p \times 1}{20}$$

$$N_s = \frac{2000 \times 1}{20}$$

$$N_s = 100 \text{ Turns}$$

ii) secondary voltage when the primary is supplied with 230V

$$\frac{V_s}{V_p} = \frac{N_s}{N_p}$$

$$V_s = \frac{V_p \times N_s}{N_p}$$

$$V_s = \frac{100 \times 230}{2000}$$

$$V_s = 11.5 \text{ Volts}$$

iii) per volts turn

$$\text{Volts per turn} = \frac{V}{N}$$

$$= \frac{230}{2000}$$

$$= 0.115 \text{ volts per turn}$$

iv) VA rating

$$S = V \times I$$

$$S = 11.5 \times 2$$

$$S = 23 \text{ VA}$$

- b)
i) Why must the transformer in (a) be a double wound type?

The secondary is isolated from the supply

- ii) Sketch the circuit symbol for a double wound transformer with an iron core.

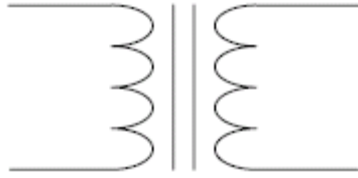

- 16 Sketch a power triangle and show on it V_{Ar} , V_A , W and phase angle. (J00)

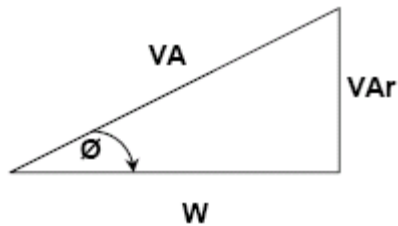

- 17 How is the output voltage of a large power transformer maintained as the load changes. (J00)

With a tapchanger

- 18
a) A transformer when fully loaded supplies 15A at 100V from the 230V mains. Its primary winding has 2000 turns. Calculate the:
i) number of secondary turns

$$\frac{N_s}{N_p} = \frac{V_s}{V_p}$$

$$N_s = \frac{N_p \times V_s}{V_p}$$

$$N_s = \frac{2000 \times 100}{230}$$

$$N_s = 870 \text{ Turns}$$

- ii) full load primary current

$$\frac{N_s}{N_p} = \frac{I_p}{I_s}$$

$$I_p = \frac{I_s \times V_s}{V_p}$$

$$N_s = \frac{15 \times 100}{230}$$

$$N_s = 6.52A$$

- iii) VA rating of the transformer

$$S = V \times I$$

$$S = 11.5 \times 2$$

$$S = 23VA$$

- b) How would a transformer of this size in (a) usually be cooled?

Natural air convection

- c) List TWO types of losses associated with all transformers.
- i. **Iron Losses**
 - ii. **Copper losses**
- d) Explain in detail why an increase in secondary current causes an increase in primary current in a double wound transformer.

When the circuit is energised, current flow in the primary winding, which by mutual inductance induces an emf into the secondary winding.

The current flow in the secondary winding produced by the load is in the opposite direction to the current flow in primary. The current flow in the secondary winding induces an emf in the primary winding that is the same polarity as the supply voltage.

This reduces the back emf in the primary winding and more current flows in the primary winding

- 19 State the effect an increase in load has on the secondary voltage of a transformer. (N99)

The secondary voltage reduces.

- 20 State the main limiting factor for the kVA rating of a power transformer. (J99)

The ability to dissipate heat.

- 21 What precaution must be taken before disconnecting a meter from the secondary of a current transformer, which is on a live circuit that cannot be isolated? (J99)

The secondary circuit must be short circuited.

THEORY

22 A 400V, three phase supply is connected through a three phase loss free transformer with a turn ratio of 1:1, which has its primary connected in delta and it's secondary in star to a load comprising 10 ohms resistors connected in delta.

i) Sketch a diagram of the circuit.

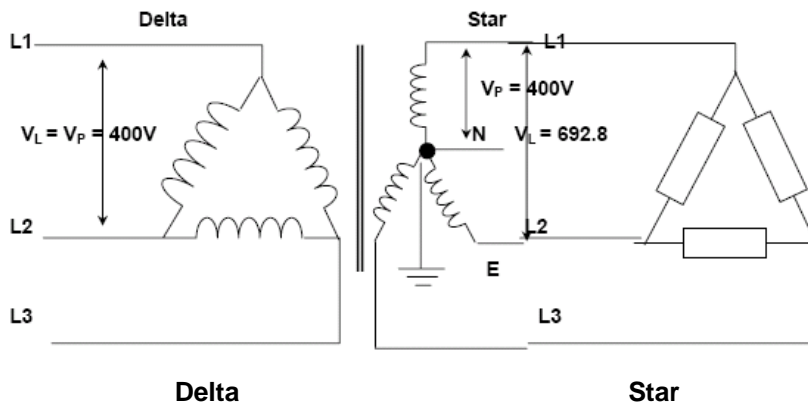

ii) Calculate the:
 (1) secondary phase voltage

Secondary $V_{ph} = 400V$ because transformer ratio is 1:1

(2) secondary line voltage

$$\begin{aligned}
 V_L &= V_{ph} \times \sqrt{3} \\
 V_L &= 400 \times \sqrt{3} \\
 V_L &= 693V
 \end{aligned}$$

(3) phase current in the load

$$\begin{aligned}
 I_{ph} &= \frac{V_{ph}}{R_{ph}} \\
 &= \frac{693}{10} \\
 &= 69.3A
 \end{aligned}$$

(4) line current to the load

$$\begin{aligned}
 I_l &= I_{ph} \times \sqrt{3} \\
 &= 69.3 \times \sqrt{3} \\
 &= 120A
 \end{aligned}$$

(5) line current to the transformer

I_l to transformer

$$\begin{aligned}
 I_{ph \text{ primary}} &= 120A \text{ because of the 1:1 ratio} \\
 I_L &= I_{ph} \times \sqrt{3} \\
 &= 120A \times \sqrt{3} \\
 &= 208A
 \end{aligned}$$

iii) Name TWO losses that are associated with the iron circuit of a transformer

Hysteresis
Eddy Current

23. (a) Draw and label the circuit diagram of a wattmeter connected to measure the power of a load by using a current transformer and a voltage transformer.

(5 marks)

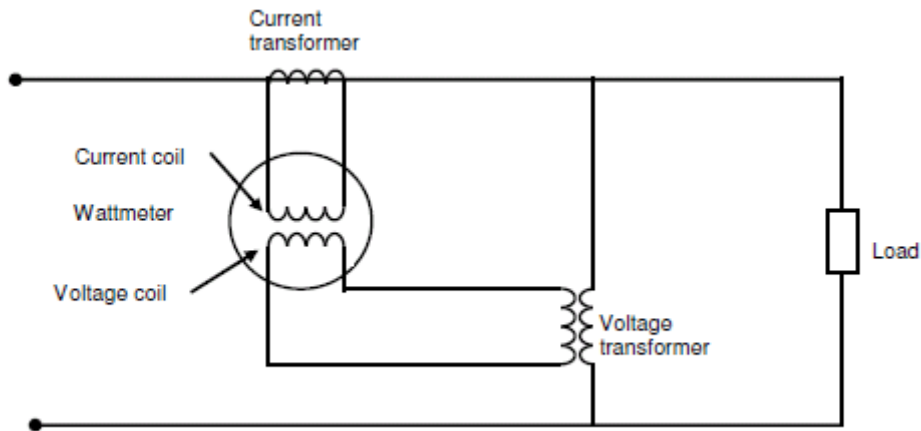

(b) A 150 kVA, three-phase, delta-star-connected step-down transformer has a phase-turns ratio of 27.5 to 1. The primary is connected to a 6.6 kV, three-phase supply, and the transformer is fully loaded.

(i) Calculate the secondary phase voltage.

(1½ marks)

$$\begin{aligned} V_{SPH} &= \frac{6600}{27.5} \\ &= 240 \text{ V} \end{aligned}$$

(ii) Calculate the secondary line voltage.

(1½ marks)

$$\begin{aligned} V_{SL} &= 240 \times \sqrt{3} \\ &= 416 \text{ V} \end{aligned}$$

(iii) Calculate the primary line current.

(2 marks)

$$\begin{aligned} I_P &= \frac{\text{kVA} \times 1000}{\sqrt{3} \times V_L} \\ &= \frac{150000}{\sqrt{3} \times 6600} \\ &= 13.1 \text{ A} \end{aligned}$$

THEORY

24. (a) The three phase low voltage supply to a factory is required to be at a voltage that is not commonly used. The factory is supplied by a 150 kVA, three-phase, delta-star-connected step-down transformer has a phase- turns ratio of 43.3 to 1. The primary is connected to an 11 kV, three-phase supply, and the transformer is fully loaded. (ET 24)

(i) Draw a diagram of the circuit, showing primary and secondary windings.

(1½ marks)

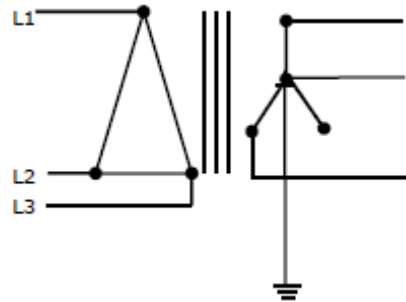

(ii) Calculate the secondary phase voltage.

(1½ marks)

$$\begin{aligned} \text{Secondary phase voltage} &= \frac{11000}{43.3} \\ &= 254 \text{ V} \end{aligned}$$

(iii) Calculate the secondary line voltage.

(1½ marks)

$$\begin{aligned} \text{Secondary line voltage} &= 254 \times \sqrt{3} \\ &= 440 \text{ Volts} \end{aligned}$$

(iv) Calculate the primary line current.

(2 marks)

$$\begin{aligned} \text{Primary line current} &= \frac{\text{kVA} \times 1000}{\sqrt{3} \times V_L} \\ &= \frac{150000}{\sqrt{3} \times 11000} \\ &= 7.87 \text{ A} \end{aligned}$$

(v) Calculate the maximum secondary line current the transformer can deliver under full load conditions.

(1½ marks)

$$\begin{aligned} \text{Secondary line current} &= \frac{150000}{\sqrt{3} \times 440} \\ &= 196.83 \text{ A} \end{aligned}$$

(b) Explain ONE practical method of reducing the iron loss of a transformer.

(2 marks)

Any ONE of:

- **The iron core is laminated.**
- **Special types of alloys are used for the core.**

25. A three-phase three-wire 11 000V supply is available for the primary connection of the delta connected transformer to a commercial site. You have taken the current measurements at the three-phase, four-wire secondary side of the transformer and have recorded the following maximum demands: (ET26)

Red = 145A White = 130A Blue = 120A
The line voltage on the secondary side is 400V.

(a) Using the information above, determine:

(i) The load in kVA of the heaviest loaded phase.

(4 marks)

$$V_{ph} = \frac{V_L}{\sqrt{3}}$$

$$\frac{400}{1.732}$$

$$230.9V \text{ or } 230V.$$

$$kVA = \frac{V_{ph} \times I}{1000}$$

$$\frac{230 \times 145}{1000}$$

$$\frac{33350}{1000}$$

$$33.35kVA \text{ on Red phase.}$$

(ii) The minimum sized kVA rating of the three phase distribution transformer required to supply load for this site.

(1½ marks)

$$\text{For 3phase load} = 33.35 \times 3$$

$$= 100050VA$$

$$\text{or } 100kVA$$

THEORY

(b) Using the information given above and from your calculations in (a), determine the maximum line current in the three-phase 11 000V system

(4½ marks)

$$\frac{I_P}{I_S} = \frac{V_S}{V_P}$$

$$I_P = \frac{I_S \times V_S}{V_P}$$

$$= \frac{145 \times 230}{11000}$$

$$= 3.03A \text{ (phase current)}$$

$$\text{Line current} = I_P \times \sqrt{3}$$

$$= 3.03 \times 1.732$$

$$5.25A$$

Alternatively it could be calculated by $I \text{ line} = \frac{VA}{\sqrt{3} \times VL}$

$$= \frac{100000 \text{ VA}}{1.732 \times 11000V}$$

$$= 5.25A$$

26. A three phase, delta-star connected transformer has a turns ratio of 956:20. The primary is connected to an 11kV three phase supply and the transformer is fully loaded. (ET28)

(a) Calculate the secondary phase voltage.

(2 marks)

$$\begin{aligned} \frac{N_s}{N_p} &= \frac{V_s}{V_p} \\ V_s &= \frac{N_s \times V_p}{N_p} \\ &= 1 \times 11000 \div 47.8 \\ &= 230.13\text{V or } 230\text{V} \end{aligned}$$

(b) Calculate the secondary line voltage.

(2 marks)

$$\begin{aligned} V_1 &= V_{ph} \times \sqrt{3} \\ &= 230.13 \times \sqrt{3} \\ &= 398.6\text{V or } 400\text{V} \end{aligned}$$

(c) If the full load primary line current is 13.12A, calculate the full load kVA rating of the transformer.

(2 marks)

$$\begin{aligned} \text{kVA} &= \frac{V_1 \times I_L \times \sqrt{3}}{1000} \\ &= \frac{11000 \times 13.12 \times \sqrt{3}}{1000} \\ &= 249.96 \text{ kVA or } 250 \text{ kVA} \end{aligned}$$

(d) Calculate the full load secondary line current.

(2 marks)

$$\begin{aligned} I_L &= \frac{\text{VA}}{(V_1 \times \sqrt{3})} \\ &= \frac{250000}{(398.6 \times \sqrt{3})} \\ &\quad \text{or} \\ &\quad \frac{250000}{(400 \times \sqrt{3})} \\ &= 362.12 \text{ or } 360.85\text{A} \end{aligned}$$

(e) When the transformer was tested on full load the single- phase terminal VPH dropped to 222 volts. Calculate the percentage regulation on the transformer

(2 marks)

$$\begin{aligned} \text{Regulation \%} &= \frac{V_{NL} - V_{FL} \times 100}{V_{NL}} \\ &= \frac{230 - 222 \times 100}{230 \quad 1} \\ &= 3.48\% \text{ or } 3.5\% \end{aligned}$$

THEORY

27. A 11kV/415V, three-phase, delta-star transformer has a 5% impedance. When fully loaded a phase current of 3.03A flows in its primary windings. Assume there are no internal losses.

(a) Calculate the full-load secondary line current.

(4½ marks)

$$\begin{aligned}\text{Sec. } V_{PH} &= \frac{\text{Sec } V_L}{\sqrt{3}} \\ &= \frac{415}{\sqrt{3}} \\ &= 239.6 \text{ volts}\end{aligned}$$

$$\begin{aligned}\text{Turns ratio} &= \frac{11000}{239.6} \\ &= 45.9 \text{ to } 1\end{aligned}$$

$$\begin{aligned}\text{Sec } I_L &= 3.03 \times 45.9 \\ &= 139.08\text{A}\end{aligned}$$

(b) Calculate the kVA rating of the transformer

(2½ marks)

$$3.03 \times \sqrt{3} = 5.25$$

$$\begin{aligned}\text{VA} &= \frac{\sqrt{3} \times PV_L \times PI_L}{1000} \\ &= \frac{\sqrt{3} \times 11000 \times 5.25}{1000} \\ &= 100 \text{ kVA}\end{aligned}$$

(c) (i) Calculate the fault level in kVA which would be produced at the transformer secondary terminals.

(1½ marks)

$$\begin{aligned}\text{kVA} &= \frac{100 \times 100}{5} \\ &= 2000 \text{ kVA}\end{aligned}$$

(ii) Calculate the prospective short circuit current that would flow if a short circuit of negligible impedance occurs across the transformer output terminals.

(1½ marks)

$$\begin{aligned}\text{ISC} &= \frac{2000}{\sqrt{3} \times 415} \\ &= 2782\text{A}\end{aligned}$$

Motors and Starters – Possible Questions

- 1 List two reasons why a shaded pole motor is used to power the fan in a portable heater. (J03)

Any two:

- **Low torque**
- **Cost effective**
- **Quiet operation**
- **Can be stalled**

- 2 Why is a three phase induction motor more efficient than the equivalent size single phase induction motor? (J03)

They have a balanced rotating magnetic field and not a pulsating one.

- 3 Give an application where a three phase motor would require phase reversal protection. (J03)

Any machinery where reverse operation may cause harm to people or damage to property.

- 4 State TWO reasons for using reduced voltage starting for a three phase induction motor. (J03)

Any two;

- **Reduce starting current**
- **Reduce voltage surges**
- **Limit mechanical shock**

- 5 What is the purpose of maintaining contacts in a direct on line reversing starter? (N02)

- **To maintain the supply to the contactor coil allowing release of the start button.**
- **To prevent automatic restarting in the event of a power interruption.**

- 6 Explain the effect that a reduction in supply voltage will have on the line currents of a loaded three phase induction motor. (N02)

The line currents will increase.

- 7 What is the cheapest type of reduced voltage starter for three phase motors, and what special requirement, if any, does this method of starting impose on the internal connections of the motor windings? (N02)

**Star – Delta
Need a six terminal motor.**

- 8 State ONE important reason for inserting external resistance into the rotor circuit of a slip ring motor at start up. (N02)

Any one

- **To reduce the starting current**
- **To produce a higher starting torque than that available from a squirrel cage motor started direct on line.**
- **To provide a more gentle start up for high inertia loads.**
- **To provide a ramped acceleration for high inertia loads.**
- **To provide a higher start torque at low speeds starting through improved rotor power factor.**

- 9 What is the main advantage of a single phase synchronous motor over other single phase motors? (J02)

It rotates at a fixed speed independent of load.

THEORY

- 10 Sketch a torque speed graph for a three phase squirrel cage induction motor. On the graph show:
- Starting torque
 - Pull out torque
 - Full load torque
 - Synchronous speed
 - Full load speed.

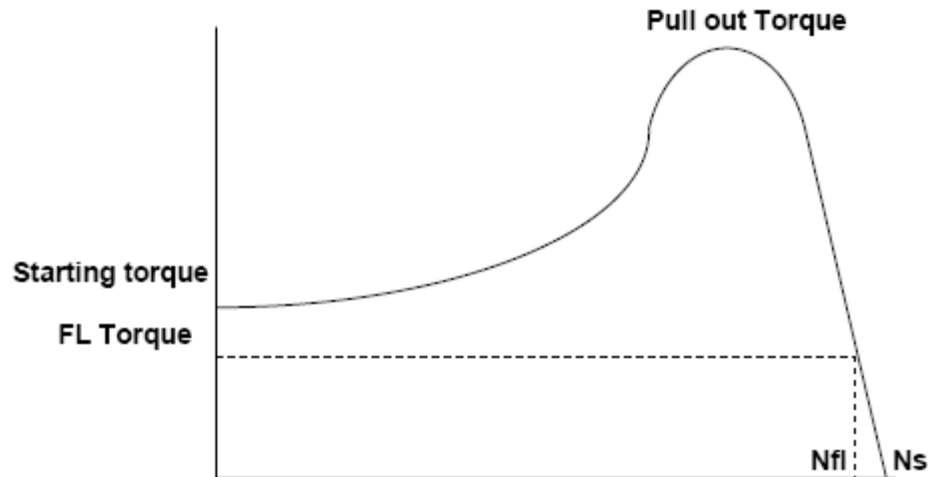

- 11 A primary resistance starter reduces the motor terminal voltage during starting by inserting resistance into each supply line. The motor terminal voltage ramps smoothly up during acceleration as a function of the decreasing line current and voltage drop across the line resistances. (J02)

Explain, in principle, how an electronic 'soft starter' achieves the same thing

Electronic soft starters utilise phase control circuitry (semiconductor switching devices such as SCRs or Triacs) to “chop up” (switch each half cycle of applied AC) at varying phase angles to provide a greater or lesser effective voltage. This provides the motor with a reduced voltage for starting, which then is ramped up smoothly during acceleration.

- 12 What type of three phase ac motor is most likely to have a wound rotor and an external resistance bank? (N01)

Slip ring or wound rotor induction motor.

- 13 Give FOUR reasons why universal motors are more suitable than single phase induction motors for use in portable power tools. (N01)

- **high power to weight ratio.**
- **Maximum torque at zero speed.**
- **Can be easily speed controlled.**
- **High speeds available.**

- 14 Give a reason why reduced voltage starting of a three phase induction motor may be required. (J01)

Any ONE;

- **High starting current / reduce starting current**
- **Permit installation of smaller cable.**
- **Smaller transformer size.**
- **Mechanical shock.**

- 15 What effect does a drop in supply voltage have on the supply current to a fully loaded, three phase, squirrel cage induction motor? (N00)

The current will increase.

- 16 List TWO advantages a capacitor-start, capacitor-run motor has over a resistance-start, split-phase induction motor. (N00)

Any TWO;

- **More starts per hour.**
- **Higher starting torque.**
- **Lower starting current.**
- **Higher power output**
- **Better power factor.**
- **More efficient.**

- 17 List TWO types of protection afforded by a direct on line starter and overload supplying a three phase motor. (N99)

Any TWO;

- **No / low voltage.**
- **Single phasing.**
- **Overcurrent.**
- **Overload.**

- 18 List THREE types of reduced voltage starters (excluding electronics) that can be used with a three phase squirrel cage induction motor.

- **Star delta.**
- **Auto transformer.**
- **Primary resistance.**

- 19 Give TWO reasons other than cost why a universal motor is used for portable tools. (J99)

Any TWO;

- **High power to weight ratio.**
- **Maximum torque produced at zero revs**
- **Easy to control speed.**

- 20 The thermal protection device in a three phase motor starter is primarily designed to disconnect the motor on the occurrence of what type of fault. (J99)

Small overload of long duration.

- 21 Sketch a typical current and torque curve for a DOL starter

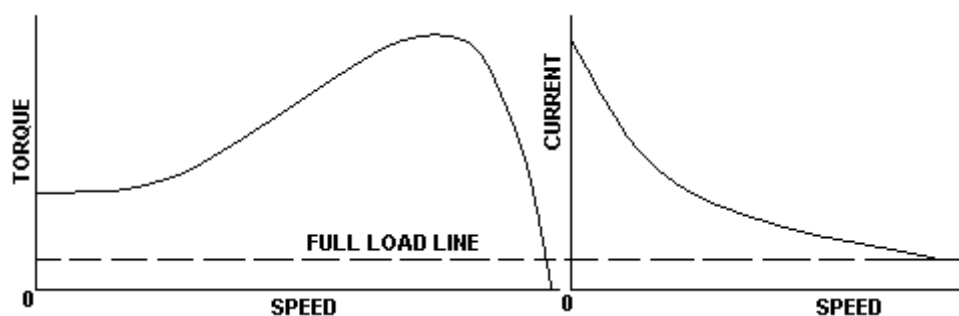

22 Sketch the current/torque curve for a star/delta connected motor.

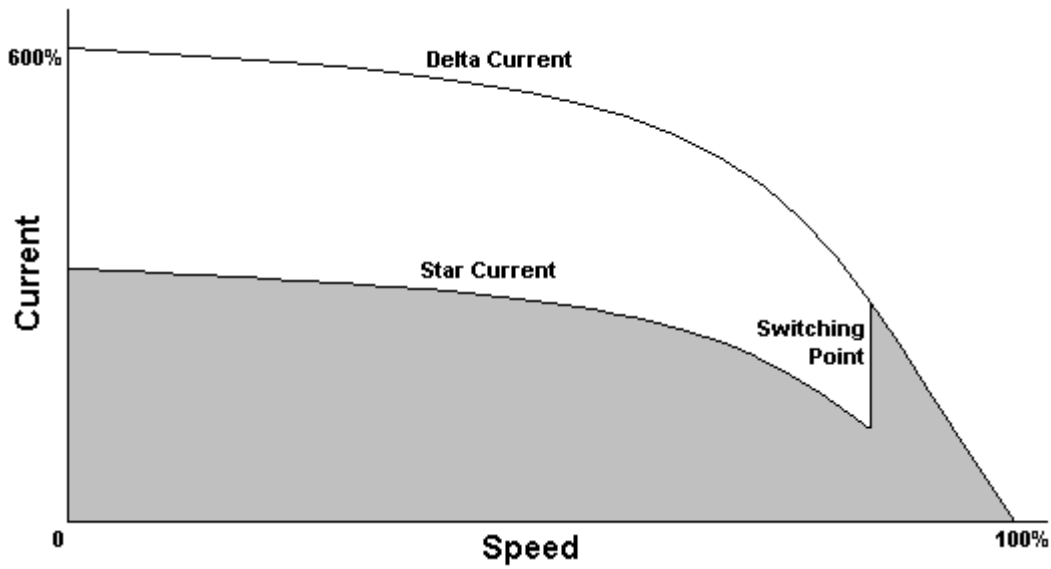
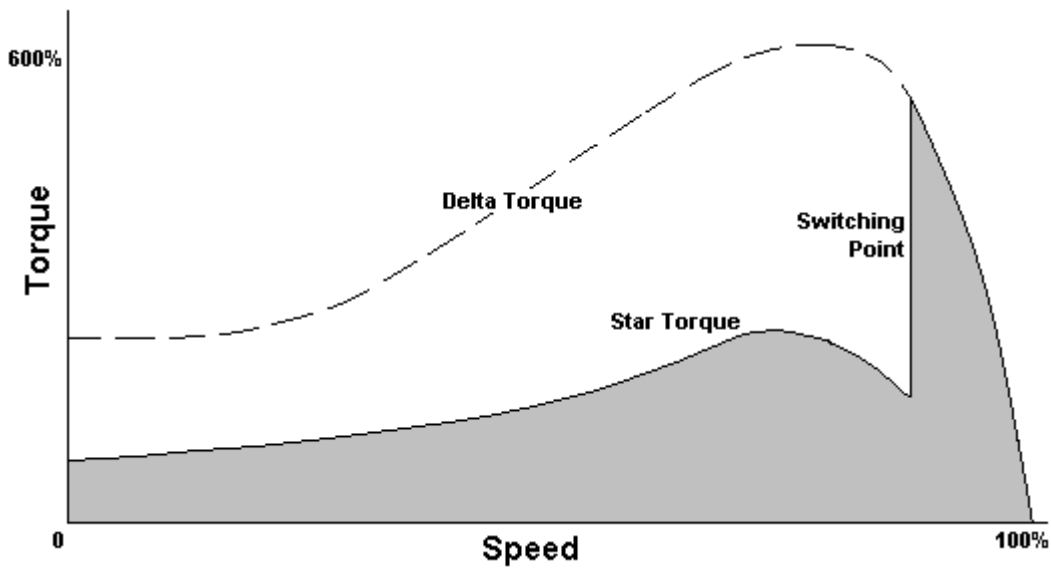

23. Give short descriptive answers to explain the following terms:

	Meaning of term	Protection method	Advantage of protection
Over current	<i>Current drawn when load exceeds motor rating</i>	<i>Overload</i>	<i>Allows a delay for any "overload" that is there in "transient" form</i>
No volt	<i>Power removed completely or to a degree where contactor no longer holds in</i>	<i>"Contactor Coil"</i>	<i>Ensures disconnection of load if supply volts drops below a sustainable level</i>
Phase reversal	<i>Changing of 2 phases which leads to a reversal of the rotating magnetic field direction</i>	<i>Phase Reversal Relay</i>	<i>Any loads that have a correct direction cannot be damaged by inadvertent phase reversal</i>
Phase failure	<i>Losing of one or more phases</i>	<i>Phase Failure relay</i>	<i>Ensures any load that requires multi-phases for operation is isolated should a phase failure occur</i>

24. When using a AC Speed drive harmonics are being generated. Why must it be kept at a minimum

The harmonics can be generated to a level that could cause serious problems within a distribution system if sufficiently high and unchecked - particularly with respect to resonance and elevated harmonic currents and heating effects.

25. When AC motors run at lower than rated speeds what precautions must be taken and why.

Motors are designed so that the fan acts as an insulant cooler. Running a motor at lower speeds removes the effectiveness of the cooling process which could lead to possible motor damage. This deficiency can be overcome by having a separately powered fan supplying a fixed volume of air directly to the cooling ducts of the motor.

THEORY

26. Complete the following table on motor starters.

Type of starter	DOL	Auto-transformer	AC Speed drive
Initial starting current (% FL)	700%	300%	Variable
Initial starting torque (% FL)	150%	80%	Variable
Relative cost	Cheap	Expensive	Expensive
Application	Light inertia loads	Hydraulic pumps heavy fans	Conveyors, processing etc.
Advantage	Full torque available on start-up - simple	3 or 6 term motors, adjustable taps to suit load	Control of motor speed from 0 to above base speed
Disadvantage	Heavy current and torque	Costly and very heavy transients	Extra cooling required if motor runs at reduced speed

27. Give a typical application for the following starters and give a reason why you have chosen that application

Starter	Application	Justification
DOL	Light inertia loads <i>e.g. lathe</i>	Cheap Starting torque maximum at turn on
Star Delta	Light loads <i>e.g. motor generator set</i>	Reduced line currents at start up
Auto transformer	Hydraulic pumps conveyors	Tappings adjustable to suit load - for same starting current¹ as primary resistance starter the torque is higher
Secondary resistance starter	Crushers, other high inertia loads	Maximum torque can be achieved at different speeds by adjusting the secondary resistance values.
Electronic speed control	Production lines	Several motors can be controlled and their speeds are synchronised to ensure smooth and co-ordinated processing

NOTE 1. The reduced current drawn from the mains in the case of an Auto Transformer starter (with respect to the Primary Resistance Starter) is due to the Transformation ratio.

28. (a) A three-phase induction motor is started by a star-delta starter

(i) State the percentage of the direct-on-Line starting torque in the start (star) position.

$$T \propto V^2 \quad \left(\frac{231}{400} \right)^2 = \left(\frac{1}{\sqrt{3}} \right)^2 = \frac{1}{3}$$

(ii) State two forms of protection' incorporated in the starter's circuitry.

Overload / no volt

(iii) Briefly explain the purpose of the interlocks.

To ensure that there is a mechanical lock-out of contactors. In the case of the above Star/Delta starter both the Star and the Delta contactors would be interlocked in such a way that both contactors cannot be closed at the same time. One way of achieving this is to have the coil of each contactor wired in series with a normally closed contact of the other contactor.

(b) The same motor could be started by an auto-transformer starter.

(i) What would be the main advantage of this starter over the star-delta starter.

The multiple tapplings on the Auto Transformer means that Higher Starting torques can be achieved than with the Star/Delta starter.

(ii) State which auto-transformer tapping should be chosen first, and give the reason.

The lowest tapping to give the motor sufficient starting torque to operate.

(iii) If the motor fails to start satisfactorily on the initial choice of tapping, what action should be taken and why.

Change the tap to the next highest level.

29. List THREE reasons for using reduced voltage starters with squirrel-cage induction motors when DOL may accelerate the load up to speed more quickly.

- **Initial starting current too high for supply main - i.e . voltage drop limitations or switchboard limitations - with respect to other connected apparatus.**
- **Initial starting current too high for the Power Supply Authority i.e other customers connected to the same feeder circuit could be effected by voltage variations caused by excessive motor starting currents.**
- **Too much stress on mechanical components i.e smoother starting.**

30. Sketch a circuit diagram of a single-phase, capacitor-start, induction-run motor.

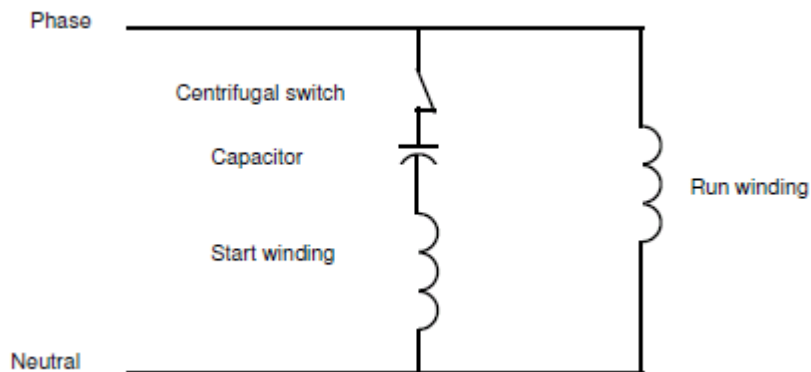

31. Sketch the power circuit diagram of a resistance starter connected to the wound rotor windings of a slip-ring induction motor. (The control circuit is NOT required).
- b. Explain what special requirements are needed when slip-ring motor controllers are used for speed control.
- c. Give TWO applications of a slip-ring motor with starter, and reasons for their use.

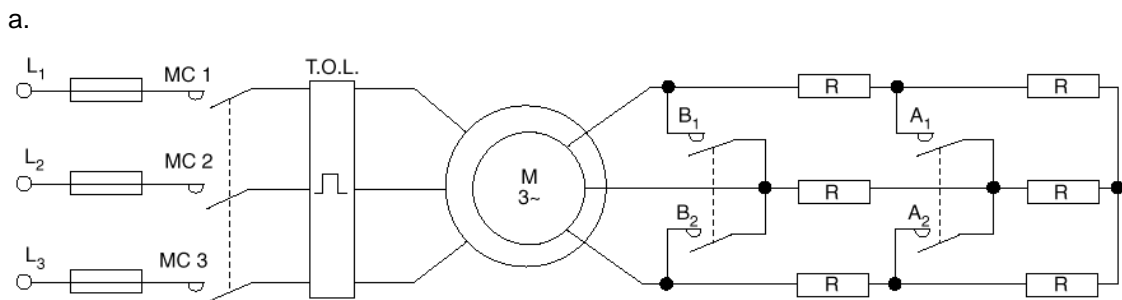

- b. **The resistors need to be continuously rated. Resistors need to be calculated for each motor because each has a different voltage and current for same KW (HP) rating.**
- c. **Overhead cranes**
Other high inertia loads
- there is no current surge during transition changes and a high starting torque.

32. A three-phase motor has windings rated at 230V and is to be connected in Star to a 400V three-phase supply. How many terminals must there be on the terminal block? (ET19)

Any ONE of:

- **Six terminals**
- **Three terminals**

THEORY

33. How is the direction of rotation reversed in a delta-connected, three-phase, squirrel-cage motor?

- **By reversing any two phase connections**

34. How is the direction of rotation reversed in a single-phase, split-phase induction motor?(ET19)

- **By reversing the connections to the start winding or run winding**

35.

(a) State THREE technical advantages that electronic starters have over electro-mechanical starters (for example, an auto-transformer starter). (ET21)

(3 marks)

Any THREE of:

- **Smoother starting – less wear and tear on the motor.**
- **Easier to adjust for overcurrent and other parameters.**
- **Visual feed-back through display panels.**
- **Physical size smaller than auto-transformer.**
- **More economical to maintain – less equipment involved.**
- **Reduces mechanical shock to equipment.**
- **More even current flow.**
- **More even torque.**
- **Torque is very constant at start.**
- **Cheaper in the larger sizes.**
- **Built-in protection and monitoring.**

(b) A three-phase induction motor is started by a star/delta starter. State TWO reasons why interlocks are used in the starter.

(2 marks)

Any TWO of:

- **To prevent the starter from switching motor windings to delta before run-up in star.**
- **To prevent phase to phase short circuit.**
- **To prevent both star and delta contactors becoming energised at the same time.**

(c) A three-phase induction motor is started by an auto-transformer starter.

(i) What would be the main advantage of this starter over a star/delta starter?

(1 mark)

Any ONE of:

- **Because there is a higher starting torque per amp of line current.**
- **There is a closer match between the tapping and load at start.**
- **Smoother start up.**

(ii) The auto-transformer has tapplings of 40%, 60% and 80%. State the reason why the 40% tapping should be chosen first.

(2 marks)

Any ONE of:

- **To keep starting current to a minimum.**
- **To ensure there is less voltage drop on the system.**

(iii) If the motor fails to start satisfactorily on the 40% tapping, what action should be taken and why?

(2 marks)

- **The next higher tapping should be tried. This will increase starting voltage, current and torque.**

36. (a) Draw and label a circuit diagram of a 230V control circuit for a three-phase DOL motor starter. Only the items listed below are to be included.

- The polarity.
- A fuse that protects the entire circuit.
- A stop button that controls the circuit.
- A start button that controls the circuit.
- A hold in contact (maintaining contact).
- A thermal overload relay contact.
- A 230V coil.

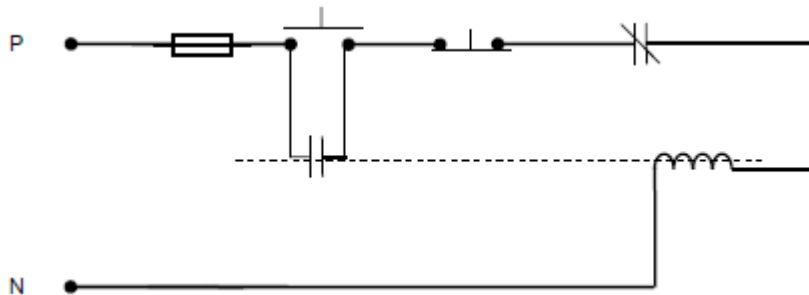

(b) Redraw the stop and start buttons you have drawn in (a) above and show how a remote stop-start station may be connected into the circuit by the use of a three-core cable.

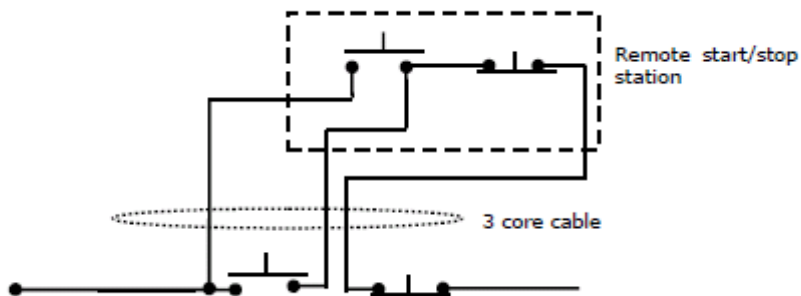

(c) State one other type of protective device that could be used in place of a thermal overload.

- **A thermistor.**

THEORY

37. (a) Describe the method by which a single-phase supply may be used to simulate a rotating magnetic field effect for a split-phase single phase induction motor. (ET26)

(5 marks)

- **The two stator windings are spaced 90 electrical degrees apart and connected in parallel to a single-phase supply.**
- **The start winding has a higher resistance and lower reactance than the run winding.**
- **The current through the start winding is closer in phase with the applied voltage.**
- **Therefore, the current through the start winding has a phase displacement to the current in the run winding.**
- **This produces the simulated rotating magnetic field.**

(b) If an external starting relay is to be used to for a single-phase, split-phase induction motor, which winding will it switch?

(1 mark)

- **The start (or auxiliary) winding.**

(c) In a single-phase, capacitor start induction motor, what would be the effect on the performance of the motor if the run winding was open-circuited:

(i) And the motor was switched on whilst on load?

(1 mark)

- **The motor would not start.**

(ii) While the motor was running whilst on load?

(3 marks)

- **The motor would slow down until the centrifugal switch closed.**
And
- **For light loads**
 - **The motor will speed up again as the start winding is energised.**
 - **The centrifugal switch will open at around 75% full-load speed so the motor will cycle as the switch opens and closes.**
- **Or**
- **For heavy loads**
 - **The motor will stall and eventually burn out.**

38. You have been requested to wire a DOL forward and reverse starter that controls a three-phase delta connected motor. (ET26)

(a) Draw and label the power circuit for the DOL starter. The drawing must show the contactors and conductors that enables the motor to be operated in the forward and reverse directions.

(3 ½ marks)

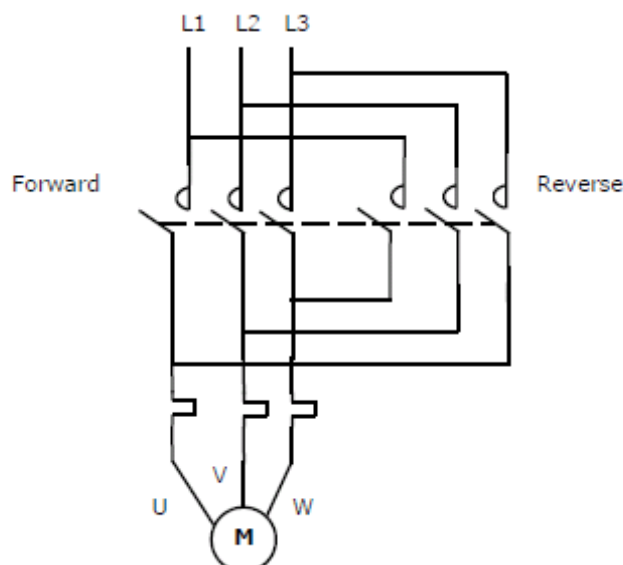

(b) Draw and label the 230V control circuit for the DOL forward and reverse starter.

(6½ marks)

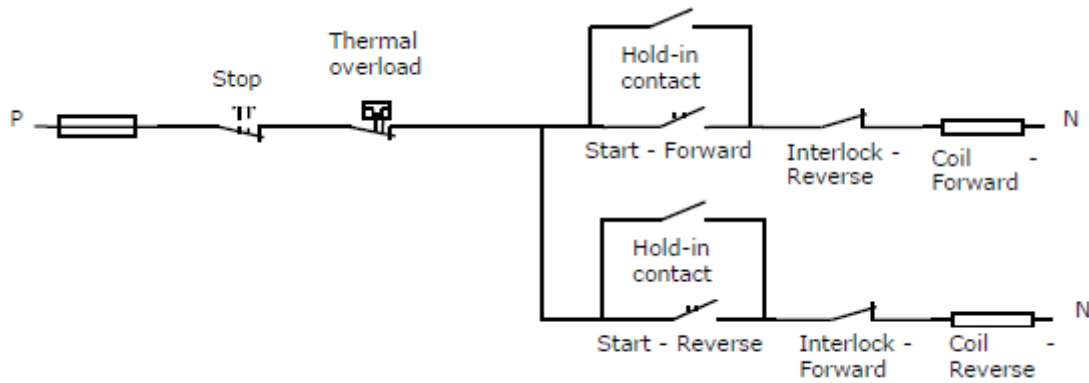

39. (a) You have been requested to wire an automatic star/delta starter for a 15kW motor in a workshop. The motor starts in star and runs in delta. (ET28)

Draw and label the power circuit for the automatic star/delta starter showing all components necessary to make it work correctly and safely.

(5 marks)

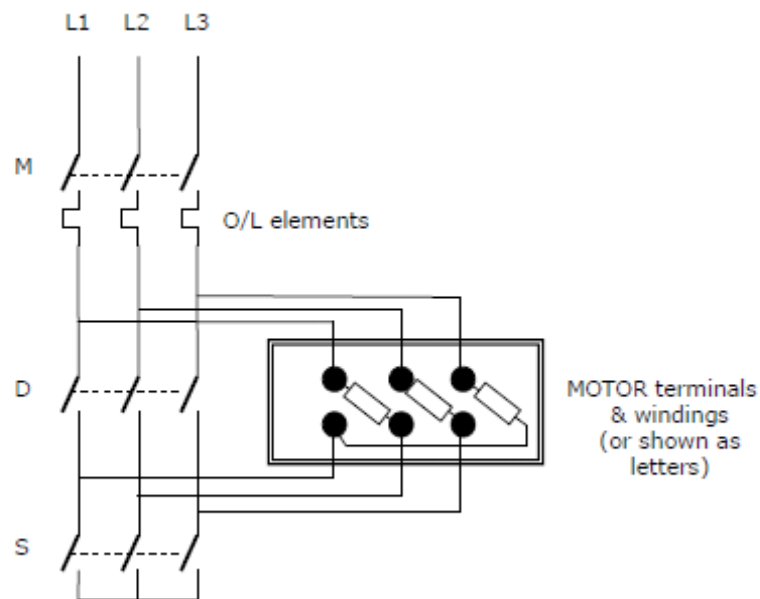

THEORY

- (b) You have been requested to wire an automatic Star/Delta starter for a 15kW motor in a workshop. The motor starts in Star and runs in Delta. Draw and label the 230V control circuit for the automatic star/delta starter showing all the components to enable it to run correctly and safely.

(5 marks)

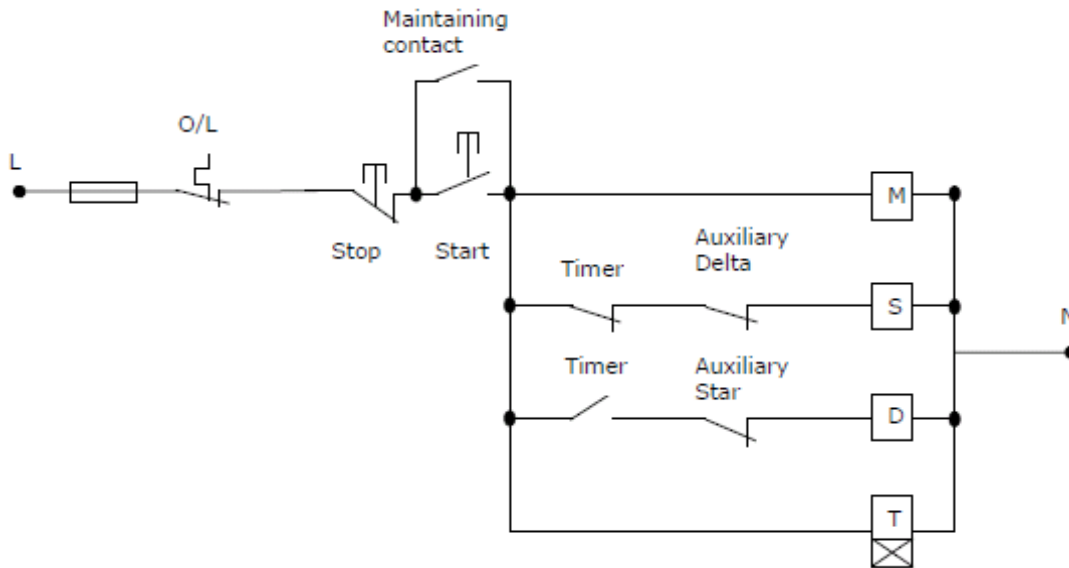

40. (a) A three-phase squirrel cage induction motor is running on full-load. It is controlled by a DOL starter.

(i) A small mechanical overload over a long period of time has occurred. What effect does this fault have on: (ET32)

- The motor
Any ONE of:
 - **The current increases**
 - **The motor slows**
 - **The motor temperature rises**

(½ mark)

- The motor protection.
Any ONE of:
 - The thermal overload will operate
 - The protection will operate

(½ mark)

(ii) A mechanical overload has occurred that caused the motor to exceed its pull-out torque (break-down torque). What effect does this fault have on:

- The motor
 - **The motor will stall**
- The motor protection.
Any ONE of:
 - **The thermal overload will operate**
 - **The protection will operate**

(½ mark)

(½ mark)

(b) A three-phase squirrel cage induction motor is running on full-load. It is controlled by a DOL starter.

(i) Under-voltage has occurred on the supply to the motor and starter. What effect does this fault have on:

- The motor
Any ONE of:
 - **The motor will slow**
 - **Excess current will flow**
 - **Motor torque will reduce**
- (½ mark)

- The motor protection.
Any ONE of:
 - **The thermal overload will operate**
 - **The protection will operate**
 - **The differential overload will operate**
- (½ mark)

(ii) An open circuit has occurred in one winding of the motor. What effect does this fault have on:

- The motor
Any ONE of:
 - **The motor will stall**
 - **A high current will flow**
- (½ mark)

- The motor protection.
Any ONE of:
 - **The thermal overload will operate**
 - **The protection will operate**
 - **The differential overload will operate**
- (½ mark)

(c) Describe how the reduction in speed of a three-phase induction motor caused by an increase in mechanical load causes an increase in line current.

(6 marks)

- **Motor slowing creates more slip**
- **Increase in rotor frequency**
- **Rotor voltage and current increases**
- **Creates more rotor flux**
- **This will reduce the back-emf in the stator windings.**
- **So the effective voltage applied to the stator windings increases**
- **So the stator current increases.**

Motor Calculations

Question 1

A 400V, 7.5kW, 50Hz, four pole induction motor has a slip of 5% when operating at full load.

- (a) State the frequency of the motor currents at start.

50 Hz

- (b) Calculate the frequency of the rotor currents at full load speed.

$$\begin{aligned}f &= \text{slip}\% \times f_{\text{supply}} \\ &= 0.05 \times 50 \\ &= 2.5\text{Hz}\end{aligned}$$

- (c) If the motor has a power factor of 0.8 and draws a full load current of 18A, calculate the efficiency of the motor at full load.

$$\begin{aligned}P &= \sqrt{3} \times V_L \times I_L \cos \phi \\ &= \sqrt{3} \times 400 \times 18 \times 0.8 \\ &= 9976\text{W}\end{aligned}$$

$$\begin{aligned}\eta &= \frac{P_{out}}{P_{in}} \\ &= \frac{7500}{9976} \\ &= 0.75 \\ &= 75\%\end{aligned}$$

Question 2

A delta connected fully loaded induction motor draws 90A from a 400V supply when started direct online. Show by calculation the current at start up that the motor would draw when connected to a star delta starter in the star position.

$$\begin{aligned}
 I_P &= \frac{I_L}{\sqrt{3}} \\
 &= \frac{90}{\sqrt{3}} \\
 &= 52A
 \end{aligned}$$

$$\begin{aligned}
 \text{Ratio}_{\text{Delta Star}} &= \frac{V_{\text{Delta}}}{V_{\text{Star}}} \\
 &= \frac{400}{230} \\
 &= 1.732 \\
 &= \sqrt{3}
 \end{aligned}$$

$$\begin{aligned}
 I &= \frac{I_{P(\text{Delta})}}{\text{Ratio}_{\text{Delta Star}}} \\
 &= \frac{52}{\sqrt{3}} \\
 &= 30A
 \end{aligned}$$

Question 3

State the formula for calculating the torque of a motor from its power and speed ratings.

$$\begin{aligned}
 P_{out} &= \frac{2\pi N_r T}{60} \\
 T &= \frac{60P_{out}}{2\pi N_r}
 \end{aligned}$$

Question 4

An engineering workshop has its own motor generator set producing three phase AC for their high speed angle grinders, which are fitted with squirrel cage induction motors. The prime mover is a four pole induction motor running at 6% slip, and the alternator has 36 poles per phase.

Calculate the alternator output frequency.

$$\begin{aligned} N_{sync} &= \frac{60f}{P} \\ &= \frac{60 \times 50}{2} \\ &= 1500rpm \end{aligned}$$

$$\begin{aligned} N_{rotor(Alternator)} &= N_{sync} - N_{slip} \\ &= 1500 - (0.06 \times 1500) \\ &= 1410rpm \end{aligned}$$

$$\begin{aligned} f &= \frac{N_{rotor}P}{60} \\ &= \frac{1410 \times 18}{60} \\ &= 423Hz \end{aligned}$$

Question 5

(a) Calculate the full load line current for a 15kW, 400V, three phase induction motor with an efficiency of 87% and a power factor of 0.8 lagging.

$$\begin{aligned} \eta &= \frac{P_{out}}{P_{in}} \\ P_{in} &= \frac{P_{out}}{\eta} \\ &= \frac{15000}{0.87} \\ &= 17240W \end{aligned}$$

$$\begin{aligned} P_{in} &= \sqrt{3} \times V_L I_L \cos \phi \\ I_L &= \frac{P_{in}}{\sqrt{3} \times V_L \cos \phi} \\ &= \frac{17240}{\sqrt{3} \times 400 \times 0.8} \\ &= 31.1A \end{aligned}$$

(b) For the motor in (a):

- i. Sketch the power triangle.

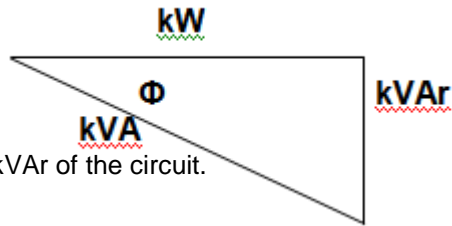

- ii. Calculate the kVAr of the circuit.

$$\begin{aligned}\phi &= \cos^{-1}(pf) \\ &= \cos^{-1}(0.8) \\ &= 36.86^\circ\end{aligned}$$

$$\tan \phi = \frac{kVAr}{kW}$$

$$kVAr = \tan \phi \times kW$$

- iii. Calculate the kVAr of the capacitor used to improve the power factor to 0.95 lagging.

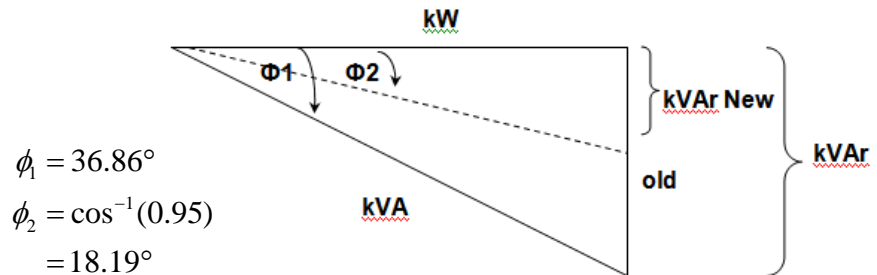

$$\phi_1 = 36.86^\circ$$

$$\begin{aligned}\phi_2 &= \cos^{-1}(0.95) \\ &= 18.19^\circ\end{aligned}$$

$$\begin{aligned}kVAr &= P_{in} (\tan \phi_1 - \tan \phi_2) \\ &= 17.24 (\tan(36.86) - \tan(18.19)) \\ &= 7.26 kVAr\end{aligned}$$

Question 6

A three phase motor has the following details on the nameplate:

- Volts 230/400
- Amps 40/23
- PF 0.7
- KW 10

(a) How should the motor windings be connected if the supply is 400V three phase?

Star _____

(b) What full load current would be drawn by the motor with the connection in (a)?

23A _____

(c) Explain the significance of each of the following:

i. PF 0.7

The ratio between true and apparent power at full load _____

ii. KW 10

This is the maximum power the motor can produce _____

(d) Calculate the efficiency of the motor at full load.

$$\begin{aligned} \eta &= \frac{P_{out}}{P_{in}} \\ &= \frac{P_{out}}{\sqrt{3} \times V_L I_L pf} \\ &= \frac{10 \times 10^3}{\sqrt{3} \times 400 \times 23 \times 0.7} \\ &= 0.897 \\ &= 89.7\% \end{aligned}$$

(e) Explain why this motor would not be suitable for connection to a star delta starter.

The phase windings are intended for 230V only. _____
If it were exceeded the insulation could break down causing the motor _____
to burn out _____

Question 7

A 400V, 50Hz, three phase star connected alternator supplies a delta connected four pole induction motor that has a full load efficiency of 87% and a power factor of 0.8. The motor is rated at 14920W.

(a) Calculate the current in each motor winding.

$$\begin{aligned}
 P_{in} &= \sqrt{3} \times V_L I_L \cos \phi \times \eta \\
 I_L &= \frac{P_{in}}{\sqrt{3} \times V_L \cos \phi \times \eta} \\
 &= \frac{14920}{\sqrt{3} \times 400 \times 0.8 \times 0.87} \\
 &= 30.94A
 \end{aligned}$$

$$\begin{aligned}
 I_{ph} &= \frac{I_L}{\sqrt{3}} \\
 &= \frac{30.94}{\sqrt{3}} \\
 &= 17.86A
 \end{aligned}$$

(b) Calculate the current in each alternator winding.

$$\begin{aligned}
 I_P &= I_L \\
 &= 30.94A
 \end{aligned}$$

(c) Calculate the speed of the motor if it has 3% slip.

$$\begin{aligned}
 N_{Sync} &= \frac{60f}{P} \\
 &= \frac{60 \times 50}{2} \\
 &= 1500rpm
 \end{aligned}$$

$$\begin{aligned}
 N_{rotor(Alternator)} &= N_{sync} - N_{slip} \\
 &= 1500 - (0.03 \times 1500) \\
 &= 1455rpm
 \end{aligned}$$

Question 8

A three phase 6kW induction motor connected to a 400V, 50Hz, three phase supply has a power factor of 0.75 and an efficiency of 80% when fully loaded.

(a) Calculate the input power.

$$\begin{aligned} P_{in} &= \frac{P_{out}}{\eta} \\ &= \frac{6000}{0.8} \\ &= 7.5kW \end{aligned}$$

(b) Calculate the input kVA.

$$\begin{aligned} kVA &= \frac{kW}{\cos \phi} \\ &= \frac{7.5}{0.75} \\ &= 10kVA \end{aligned}$$

(c) Calculate the input kVAr.

$$\begin{aligned} kVAr &= \sqrt{kVA^2 - kW^2} \\ &= \sqrt{10^2 - 7.5^2} \\ &= 6.6kVAr \end{aligned}$$

(d) Calculate the phase angle.

$$\begin{aligned} \phi &= \cos^{-1}(pf) \\ &= \cos^{-1}(0.75) \\ &= 41.4^\circ \end{aligned}$$

(e) Calculate the line current.

$$\begin{aligned} P_{in} &= \sqrt{3} \times V_L I_L \cos \phi \\ I_L &= \frac{P_{in}}{\sqrt{3} \times V_L \cos \phi} \\ &= \frac{7500}{\sqrt{3} \times 400 \times 0.75} \\ &= 14.4A \end{aligned}$$

(f) Sketch and label a power triangle for this circuit.

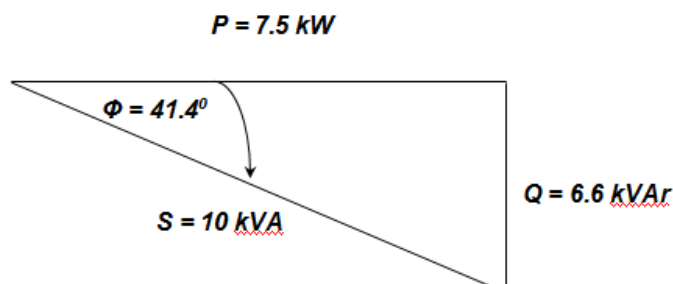

Question 9

An electric motor has a nameplate as shown below:

Frame	D1323	Output	5.5kW	HP	7 1/2
Pole	4	RPM	1450	INS	F
Volts	380/415	Amps	11.6/10.7	Hz	50
Rating	SI MCR	Design	IEC	IP	55
Date	1998	Bearings	6308		
Weight	6.6kg	Serial No	1203358F		

- (a) Calculate the power factor of the motor with an efficiency of 85% when supplying full load and connected to a 415V supply

$$P_{in} = \frac{P_{out}}{\eta}$$

$$= \frac{5500}{0.85}$$

$$= 6470W$$

$$P_{in} = \sqrt{3} \times V_L I_L \cos \phi$$

$$\cos \phi = \frac{P_{in}}{\sqrt{3} \times V_L I_L}$$

$$= \frac{6470}{\sqrt{3} \times 415 \times 10.7}$$

$$= 0.84^{\circ}lag$$

- (b) What is signified by the letters IP and the numerals 55 (IP55) on the nameplate.

IP = Ingress Protection

55 = Prevents dust and moisture ingress

- (c) Calculate the percentage slip speed of the motor at full load.

$$N_{sync} = \frac{60f}{P}$$

$$= \frac{60 \times 50}{2}$$

$$= 1500rpm$$

$$Slip = \frac{N_{sync} - N_{rotor}}{N_{rotor}}$$

$$= \frac{1500 - 1450}{1500}$$

$$= 0.033$$

$$= 3.3\%$$

Question 10

An electric motor has a nameplate as shown below:

TYP	MOT 112M	No.	MOT 112M	Year	1996
KW	4.0	H _v		Hz	50
RPM	1440	Phase	3-	Ins	F
Ambient temp		Cos φ	0.82	η %	
Duty	S1	Protection	IP		
V	415	Δ		V	
A	8.52			A	
		Y			

(a) Calculate the motor efficiency.

$$\begin{aligned}
 \eta &= \frac{P_{out}}{P_{in}} \\
 &= \frac{P_{out}}{\sqrt{3} \times V_L I_L pf} \\
 &= \frac{4000}{\sqrt{3} \times 415 \times 8.52 \times 0.82} \\
 &= 0.797 \\
 &= 79.7\%
 \end{aligned}$$

(b) Calculate the percentage slip at full load

$$\begin{aligned}
 Slip &= \frac{N_{sync} - N_{rotor}}{N_{rotor}} \\
 &= \frac{1500 - 1440}{1500} \\
 &= 0.04 \\
 &= 4\%
 \end{aligned}$$

Question 11

A three phase 4 pole motor has the following details on the characteristics:

- Supply Frequency 50Hz
- Line Voltage 400V
- Line Current 85A
- Efficiency 85%
- Slip 4%
- Line current lags voltage by 35°

(a) Calculate the rotor speed of the motor.

$$\begin{aligned} N_{sync} &= \frac{60f}{P} \\ &= \frac{60 \times 50}{2} \\ &= 1500rpm \end{aligned}$$

$$\begin{aligned} N_{rotor(Alternator)} &= N_{sync} - N_{slip} \\ &= 1500 - (0.04 \times 1500) \\ &= 1440rpm \end{aligned}$$

(b) Calculate the power factor of the motor

$$\begin{aligned} pf &= \cos \phi \\ &= \cos 35^\circ \\ &= 0.82 \end{aligned}$$

(c) Calculate the output power of the motor

$$\begin{aligned} P_{out} &= \sqrt{3} \times V_L I_L \cos \phi \times \eta \\ &= \sqrt{3} \times 400 \times 85 \times 0.82 \times 0.85 \\ &= 41kW \end{aligned}$$

THEORY

12. A three-phase, 8 kW induction motor connected to a 400 V, 50 Hz, three-phase supply has a power factor of 0.81 and an efficiency of 84% when fully loaded. (ET21)

Calculate:

(i) The input power

(2 marks)

$$\begin{aligned}\text{Eff.} &= \frac{\text{output}}{\text{input}} \\ \text{Input} &= \frac{\text{output}}{\text{eff.}} \\ &= \frac{8}{0.84} \\ &= 9.5 \text{ kW}\end{aligned}$$

(ii) The input kVA

(2 marks)

$$\begin{aligned}\text{kVA} &= \frac{\text{kW}}{\text{Pf}} \\ &= \frac{9.5}{0.81} \\ &= 11.7 \text{ kVA}\end{aligned}$$

(iii) The line current

(2 marks)

$$\begin{aligned}P &= \sqrt{3} V_L I_L \text{ PF} \\ I_L &= \frac{P}{\sqrt{3} V_L \text{ PF}} \\ I_L &= \frac{9500}{\sqrt{3} \times 400 \times 0.84} \\ I_L &= 16.3 \text{ A}\end{aligned}$$

(iv) State ONE reason why reduced-voltage starting of a large three-phase induction motor may be required.

(1 mark)

Any ONE of:

- Reduce starting current.
- Permits the installation of a smaller cable.
- Smaller transformer size can be used.
- Reduce mechanical shock.
- Reduce the effect of volt drop on the system.

Alternators

1 List TWO examples of prime movers used to drive large alternators.

Any TWO of;

- diesel motor
- water turbine
- petrol motor
- gas turbine
- steam turbine.

2 Name the TWO types of rotors that are used in alternators.

- Salient pole.
- Cylindrical.

3 Name the two factors that determine the frequency of the generated emf.

- Number of poles on the rotor.
- Speed at which the rotor is driven

4 Calculate the frequency of the e.m.f. generated in each phase of a 3 phase 4 pole turbo-alternator when it is running at:

a) 1500 rev/min.

$$N_s = \frac{f \times 60}{P}$$

$$f = \frac{P \times N}{60}$$

$$f = \frac{2 \times 1500}{60}$$

$$f = \underline{50 \text{ Hz}} \rightarrow$$

b) 2000 rev/min.

$$N_s = \frac{f \times 60}{P}$$

$$f = \frac{P \times N}{60}$$

$$f = \frac{2 \times 2000}{60}$$

$$f = \underline{66.67 \text{ Hz}} \rightarrow$$

THEORY

- 5 Explain the basic principles of AC generation.
- **Relative motion between the conductor and magnetic field is needed to induce an e.m.f. in the conductor.**
 - **The magnetic field system is placed on the rotating part called the rotor.**
 - **The conductors, in which the e.m.f. is induced are wound on the stationary part, called the stator.**
 - **Rotor is driven by a prime mover, which creates a rotating magnetic field.**
 - **Exciter (dc generator) supplies dc to the rotor**

- 6 How is the output frequency of an AC generator increased?

The speed of rotation is increased

- 7 A 4-pole alternator rotates at a speed of 500rpm. Calculate the frequency it will produce.

$$N_s = \frac{f \times 60}{P}$$

$$f = \frac{N \times P}{60}$$

$$\frac{500 \times 2}{60}$$

$$f = 16.667 \text{ Hz}$$

- 8 A 230v 50Hz alternator has 8 poles.
a) What must the speed be to maintain 50Hz?

$$N_s = \frac{f \times 60}{P}$$

$$N_s = \frac{50 \times 60}{4}$$

$$750 \text{ RPM}$$

- b) If the frequency had to be changed to 75Hz what must the speed be now?

$$N_s = \frac{f \times 60}{P}$$

$$N_s = \frac{75 \times 60}{4}$$

$$= 1125 \text{ RPM}$$

- 9 A 230v 50Hz alternator rotates at 1500 RPM. How many poles must this alternator have to maintain the speed and to maintain the same frequency?

Note: Question asked how many poles thus, pole pairs $\times 2 = 4$ poles

$$N_s = \frac{f \times 60}{p}$$

$$p = \frac{f \times 60}{N_s}$$

$$\frac{50 \times 60}{1500}$$

$$= 2 \text{ pole pairs}$$

Lighting

1 Explain each of the following faults in a switch-start fluorescent fitting: (N03)

- a) The tube does not strike and ends are glowing.

Faulty starter

- b) The tube attempts to strike but fails to maintain conduction.

Faulty tube

- c) The tube ends are blackened and the light outputs is low.

End of tube life

- d) What would be the effect on the operation of a discharge lamp if the ballast short-circuited while working.

When working normally the ballast is in series with the lamp to limit the current. If the ballast becomes short circuited for any reason the voltage appearing across the lamp increases and consequentially the current increases resulting in the lamp eventually failing.

- e) If the capacitor across a starter of a fluorescent light fitting short circuits, what effect does this have on the operation of the lamp.

The shorted suppression capacitor short circuits the starter contacts. Therefore, the potential difference across these contacts is not enough to ionise the gas in the starter and heat the bimetal necessary for operation. No inductive voltage surge is produced because the switching action of the starter fails to occur. The lamp filaments at each end of the tube will glow continuously and eventually burn out.

- f) Explain why single tube fluorescent fittings should not be installed in a machine shop?

Flicker of the lamp (Stroboscopic effect) can make rotating machinery appear stationary.

THEORY

2 State a typical application for each of the following lamps and give a reason for your choice.(J03)

a) Sodium Vapour (Low Pressure)

Application: Street lighting.

Reason: Any application where long life and high efficacy are important and good colour rendition is not important.

b) Metal halide.

Application: Sports ground.

Reason: Any application where long life, high efficacy and good colour rendition are important.

c) List FOUR essential requirements for good lighting

- **Sufficient light**
- **No Glare**
- **Uniform light**
- **Correct colour**

d) State TWO precautions that must be taken when handling and installing linear type halogen lamps.

Any Two

- **Do not touch with naked finger**
- **Install in horizontal position only**
- **Do not cause excessive vibration**
- **Isolation circuit**

3 The owner of a hairdressing salon needs advice about replacing all of the old (cool fluorescent tubes in the salon. Ignoring cost, state the predominant consideration when recommending replacement tubes. (N02)

Give the reason for your answer.

Colour rendering – require ability to discern / judge hair colour treatments accurately

4

- a) The figure below shows a High pressure mercury vapour lamp. Label the lamp appropriately using number from the list provided. (J02)

- (1) Internally phosphor-coated outer jacket
- (2) Main electrodes
- (3) Secondary electrodes
- (4) Arc (discharge) tube

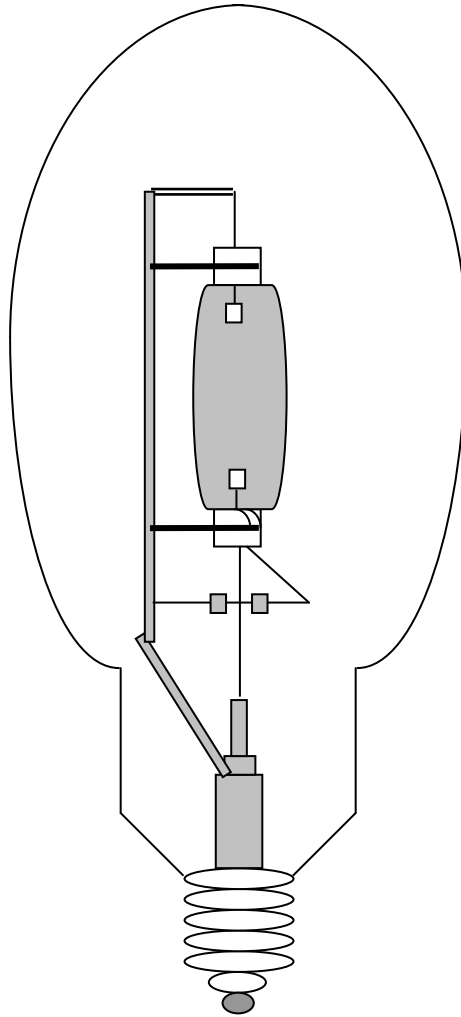

- b) If discharge lighting that has been on for some time loses power momentarily (eg switched off and then on again) it take several minutes for the lamps to strike.

Briefly explain the reason for this.

It take a few minutes for the vapour pressure inside the (hot) arc Tube to reduce (as its cools) enough for the starting discharge (between one of the main electrodes and the starting electrode) to arc across and strike the lamp again.

THEORY

- 5 Described below are situations that relate to the operation of gas discharge lamps and their control circuits. (N02)

Clearly state one associated hazard for each of the situations below.

- a) Use of a standard multimeter to measure output in high pressure sodium or multi-vapour lamp control circuits.

Damage to meter and / or shock hazard due to HV pulse from igniter (typically 4-5kV up to 10kV)

- ii. Breakage of low-pressure mercury vapour lamps (fluorescent tubes) either accidentally or during disposal.

iii. Disposal of low and / or high-pressure sodium vapour lamps

iv. The operation of an HID metal halide lamp with broken outer envelope.

- b) Breakage of low-pressure mercury vapour lamps (fluorescent tubes) either accidentally or during disposal.

Any one

- **Injury from glass shards**
- **Inhalation of powder (phosphors) contaminated with mercury.**

- c) Disposal of low and / or high-pressure sodium vapour lamps

Any one

- **Fire risk – sodium + moisture (water) = (produces) hydrogen.**
- **Chemical burns risk – sodium + moisture (water) = (produces) sodium hydroxide (caustic soda)**

- d) The operation of an HID metal halide lamp with broken outer envelope.

Any one

- **Serious skin burns from shortwave ultraviolet radiation**
- **Eye inflammation from shortwave ultraviolet radiation**
- **Live parts exposed**
- **Fire risk**

6

- a) Identify **each** of the components in the figure below and describe their function (or functions) in the circuit. (J01)

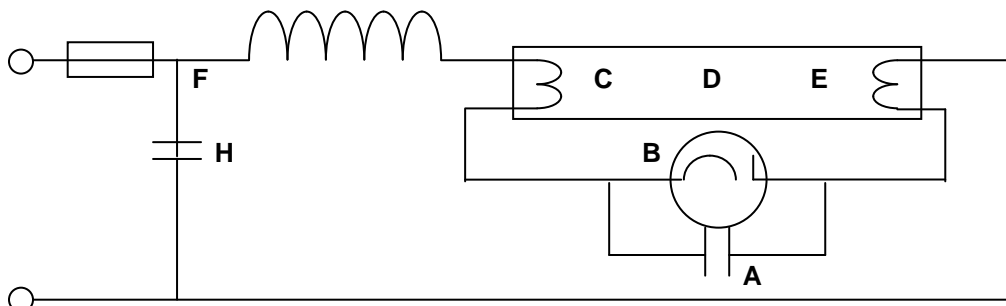

Component A:

Capacitor

Function:	Arc suppression to protect starter contacts
Component B :	Starter
Function:	Open and close inductive circuit
Component C and E :	Lamp filaments
Function:	Pre heat gas / tube
Component D :	Fluorescent tube
Function:	Produces light
Component F :	Inductor
Function:	Produces striking voltage / limits current flow
Component G :	Fuse
Function:	Protects circuit against faults
Component H :	Capacitor
Function:	Power factor correction

- b) Define the term **luminous flux** and state the letter symbol and unit.

The rate at which light energy is being emitted by light source.
Letter symbol : F or Φ
Unit : Lumens (lm)

7

- a) List the **four** essential requirements for good illumination in lighting design.(N00)

- **Minimum glare**
- **Uniformity of light**
- **Suitable colour**
- **Illuminance**

- b) Explain why single-tube fluorescent fittings should not be installed in a machine shop.

Flicker of the lamp can make rotating machinery appear stationary

- c) State a typical application for **each** of the following lamps and give a reason for your choice.

- i) Sodium vapour

Application: **Street lighting**

Reason: **Any application where**

Colour rendering is not important
Long lamp life
High efficacy
Can be focused or reflected

ii) Metal halide

Application: **Sports grounds, low voltage commercial or domestic**

Reason: **Any application where**

- Can be focused for flood lighting**
- Long lamp life**
- High efficacy**
- Time to reach maximum output important.**

iii) Fluorescent

Application: **Office, shops, factory**

Reason: **Any application where**

- Good efficacy**
- Good Colour rendition**
- Low or acceptable glare**
- Cost effective**
- Reach maximum output immediately**

8

a) Sketch and label the circuit diagram of a single-tube, switch start fluorescent light.(J00)

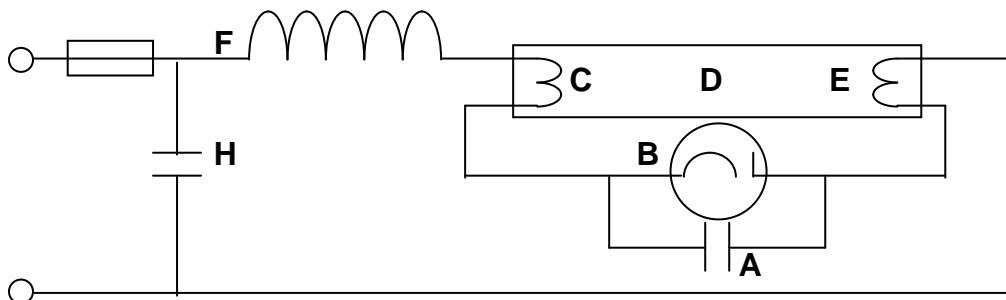

- | | |
|--------------------|------------------|
| Component A: | Capacitor |
| Component B: | Starter |
| Component C and E: | Lamp filaments |
| Component D: | Fluorescent tube |
| Component F: | Inductor |
| Component G: | Fuse |
| Component H: | Capacitor |

b) Describe the operation of the circuit in (a)

When energised current flows through the inductor, the first tube element, the starter contacts, the other tube element, and back to the supply.

When the starter opens, the magnetic field of the inductor collapses causing a large emf to be induced. This large emf ionises the gas in the tube causing electrons to flow between the tube elements in doing so the electrons collide with the phosphor-coated tube walls, causing mild explosions which give off light.

- c) Explain the cause of **each** of the following faults in a switch start fluorescent fitting:
- i) Tube does not strike and ends are glowing

Faulty starter

- ii) Tube attempts to strike but fails to maintain conduction

Faulty tube

- iii) Tube ends are blackened and light output is low

End of tube life

- 9 State two ways of reducing the stroboscopic effect caused by discharge lighting.(J99)

Any Two

- **Series capacitor in alternate fittings**
- **Lights on different phases**
- **Mixed with incandescent lighting**

- 10 What is the definition for a luminary?

An apparatus which controls the distribution of light from a lamp or lamps fixed in it and connects them to the power supply.

- 11 What is the definition for luminous intensity?

**The number of Candela(s) emitted by a light source.
Symbol for Candela is (cd)**

- 12 Name four requirements for good illumination.

**The light level is adequate for what is needed.
The colour of the output light suits the lighting application.
The brightness of the source should not cause glare.
The light should be as even as possible throughout the area to be lighted.**

- 13 What is luminous efficacy?

The lumens per watt the lamp produces.

- 14 What type of meter is used to measure illuminance?

Lightmeter or Photometer.

- 15 Name four factors that will affect the life of an incandescent lamp.

**Mounting position of the lamp.
Heavy vibrations affecting the lamp.
Ventilation affecting the lamp.
Variations in the supply voltage to the lamp.**

- 16 What does the Ra of a lamp mean?

**Colour Rendering refers to the colour impression a lamp creates on a coloured surface compared to an acceptable light source such as daylight. Colour rendition is measured in RA, where 100 is optimum.
The incandescent lamp has an RA of 100.**

Semiconductor Devices - Possible Questions

1 Sketch the circuit symbol for a photo diode. (J03)

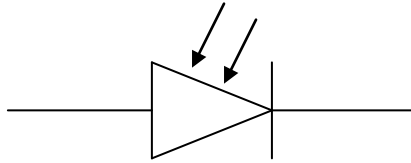

2

a) Sketch and label a circuit diagram of a three phase full wave rectifier circuit supplied from a delta-delta connected supply transformer. Indicate load polarity. (J03)

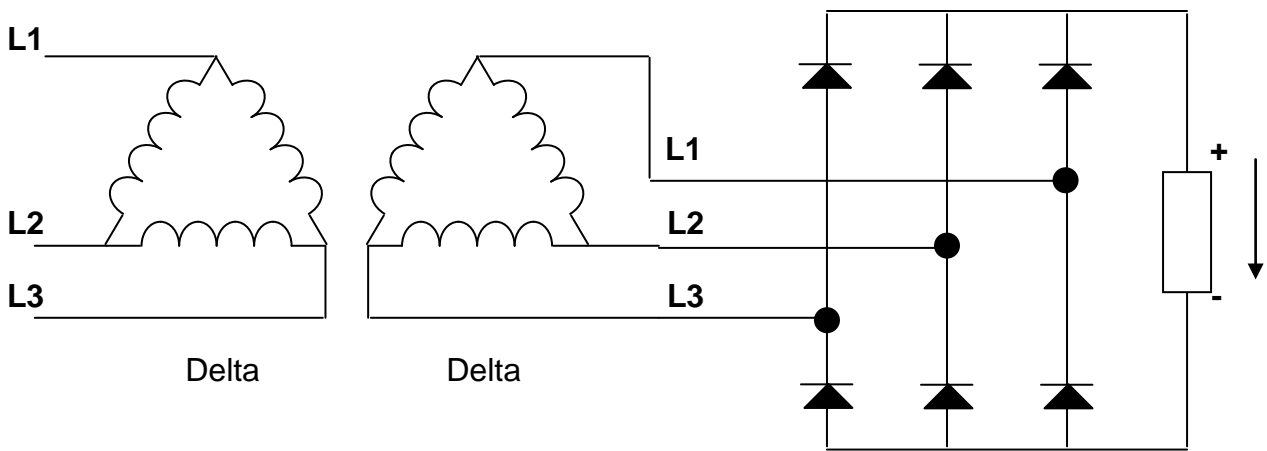

b) Sketch the output waveform for one cycle of the circuit in (a). (J03)

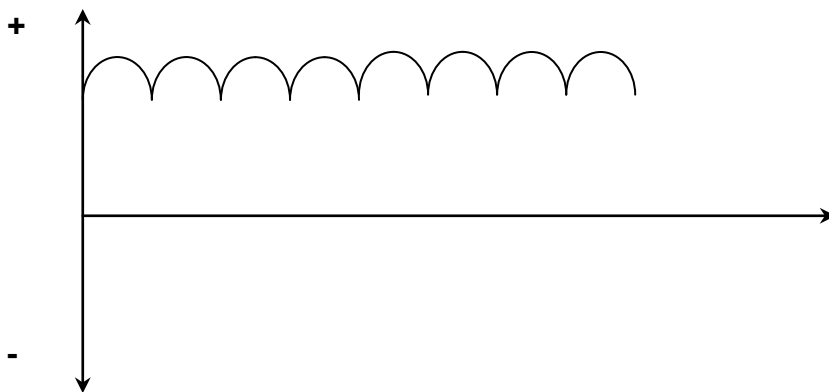

- c) A PTC thermistor has been fitted to provide thermal protection for the transformer in (a). Sketch a graph to show how the resistance changes with an increase in temperature. (J02)

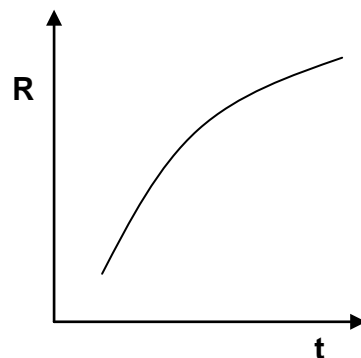

- d) If the output from the transformer in (a) was 400 V, 50 Hz, find the ripple frequency of the load voltage. (J02)

Ripple frequency.
For three phase full wave 6 times supply frequency.
 $Fr = 6 \times 50 = 300 \text{ Hz.}$

- e) State TWO components that may be used as filters in rectifier circuits. (J02)

Any TWO.

- **Capacitor.**
- **Inductor.**
- **Resistor.**

- 3 The figure below shows the circuit for an electronic speed controller, controlling a universal motor.

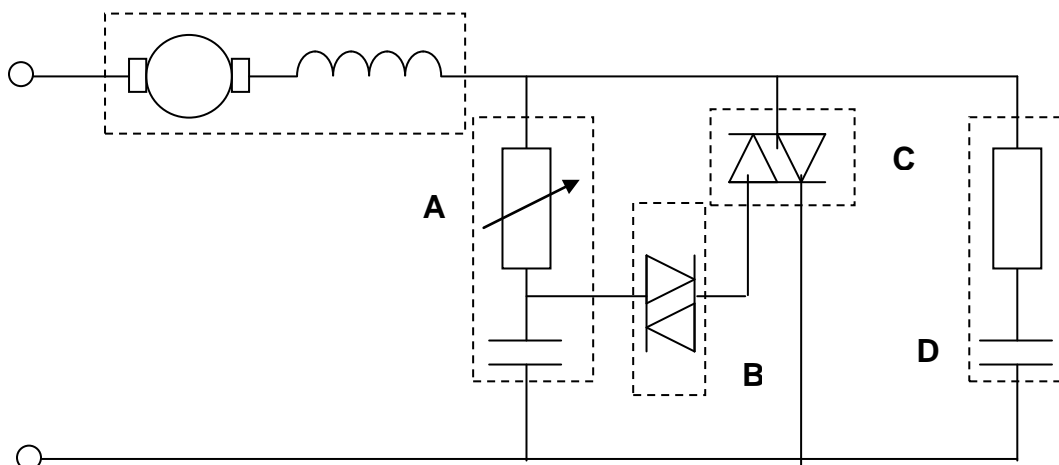

- a)
 i) **A:** Resistor capacitor timing network

The speed at which the capacitor charges is determined by the setting of the potentiometer which determines the firing angle of the circuit.

- ii) **B:** Diac

Trigger device for the Triac (C) – bi-directional, remains open circuit until break-over voltage is attained across capacitor (A), then momentarily conducts to provide a current pulse to the gate at the Triac (C) each half-cycle.

- iii) **C:** Triac

Bi-directional semiconductor switching device that affords phase control of the load thereby varying its speed.

- iv) **D:** Snubber circuit

Helps to protect the Triac from voltage spikes as it is switching an inductive load. Also helps to suppress e.m.i produced by the circuit operation.

- b) State the effect on the motor's speed if the resistance of the variable resistor is increased.

The motor speed would reduce

- c) Sketch graphs of time against current to show the:
 i) input wave form.

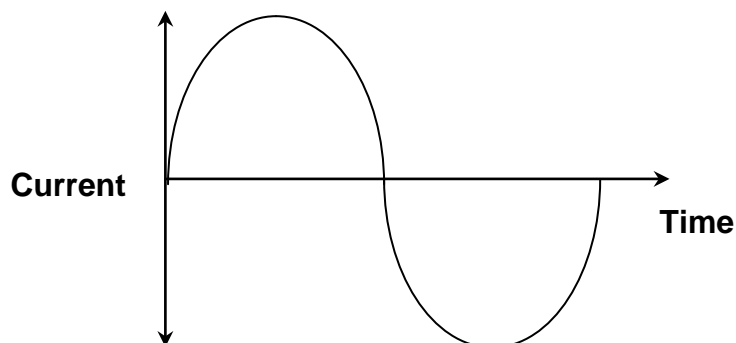

- ii) output wave form when the variable resistor is minimum

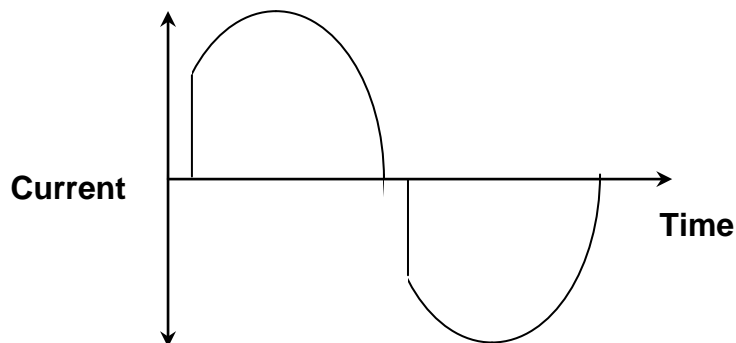

iii) output waveform when the variable resistor is half maximum

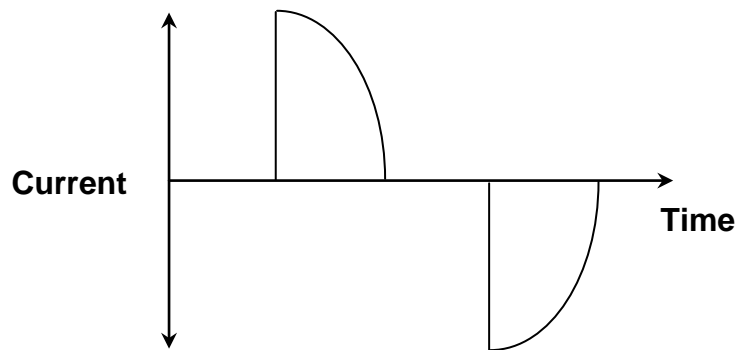

d) How could the direction of rotation of the series motor be changed?

Change the connection to the armature or field winding but not both.

4 State the names of the semiconductor devices that are used in a standard light dimmer to provide phase control. (N02)

Diac or Triac

THEORY

5 The figure below shows a transistor being used to control a current operated load. (N02)

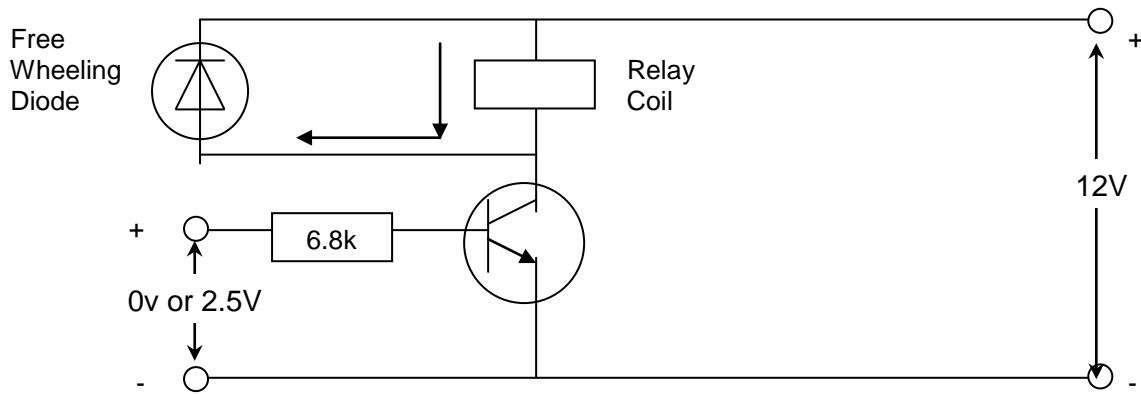

a) Describe the operation of the circuit:

In its off state.

**0V applied to 6.8 k resistor (transistor base).
Transistor is cut off and stays open circuit between collector-emitter. Acts like open switch – relay stays off. 12 V dropped across transistor.**

In its on state.

**2.5V applied to 6.8 k resistor (transistor base).
Transistor turns on (saturates) collector – emitter resistance goes low – current flows through relay energising it.**

b) State the transistor type, and explain the term saturation, with respect to its operation as a switch.

**NPN.
Saturation means the transistor is turned 'hard on' as fully as it can be. (Increased base current makes no more carriers available)**

6 Sketch the drawing symbols for EACH of the following: (J02)

- Diac

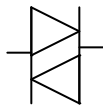

- Zener diode

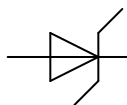

7 Name a device that can be used to protect semiconductor components against the effects of transient voltages. (J02)

Any one:

- Snubber circuit
- Surge diverter, also called MOV (metal oxide varistor)
- Free wheeling diode
- RC circuit
- Optocoupler
- UPS (uninterruptible power supply)

8

a) Draw the circuit symbol for a voltage dependent resistor (VDR). (J02)

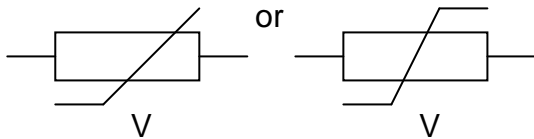

b) Explain:

i) the function of a VDR

They protect voltage sensitive equipment from spikes (voltage transients).

ii) how a VDR carries out this function

They suppress transient voltage spikes by shunting (shorting) the transient V instantly as it appears across the VDR terminals. VDR resistance is normally very high at normal voltage but plummets to very low value when a spike appears across it, thereby preventing the voltage from appearing across the voltage sensitive components.

iii) where a VDR is placed in a circuit

Across (In parallel with) the equipment to be protected

THEORY

9 Sketch the circuit symbols for each of the following: (N01)

i) Triac

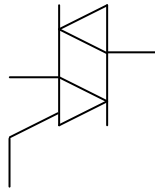

ii) NPN transistor

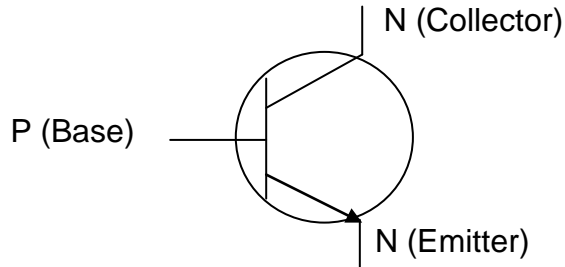

10

a)

i) Sketch and label a circuit diagram for a half-controlled, single-phase, full wave bridge rectifier supplying a resistive load.

Include in your diagram the following components;

- Single phase transformer.
- SCRs
- Diodes
- Load
- Control circuit (block only)

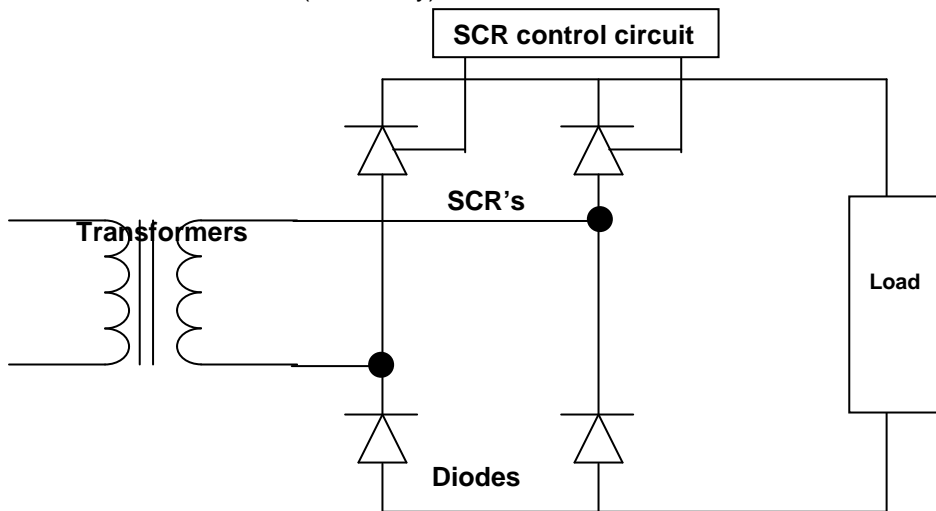

ii) Sketch the output waveform at half output.

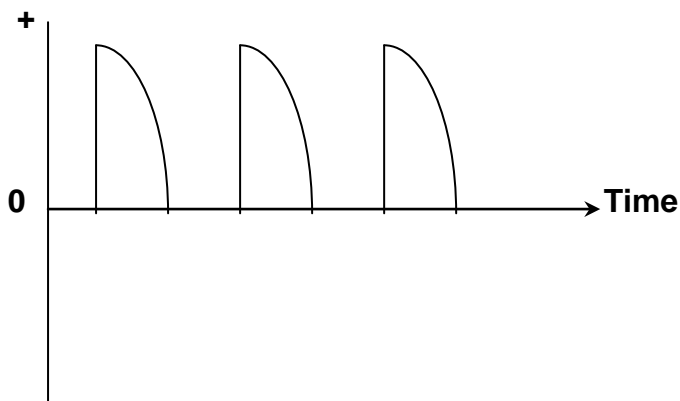

b) State TWO components that may be used as part of a circuit to filter a rectifier output.

Any Two

- **Inductor**
- **Capacitor**
- **Resistor**

c) State TWO factors that will cause an SCR to be turned off once it has been triggered (turned on). (J01)

Any Two

- **Current drops to zero**
- **Current drops to less than holding current**
- **Remove anode to cathode voltage**

11 Sketch and label the circuit symbol for EACH of the following: (J01)

i) PNP bipolar junction transistor.

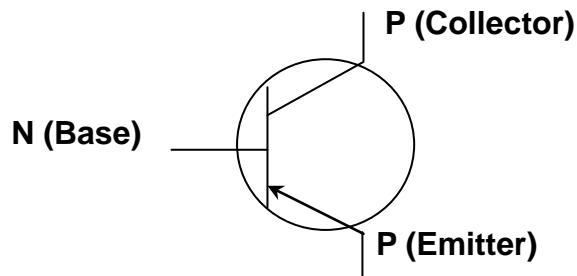

ii) A thermistor

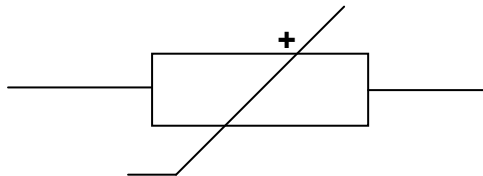

12 What is meant by the term peak inverse voltage as applied to semiconductor devices? (J01)

Maximum voltage applied to the device in the reverse bias condition

13 List TWO common applications for a transistor. (J01)

- Amplifier**
- Switches**

THEORY

14 Sketch the symbol for EACH of the following semiconductor devices: (N00)

i) Triac

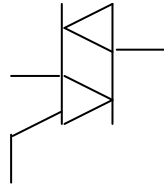

ii) Light emitting diode

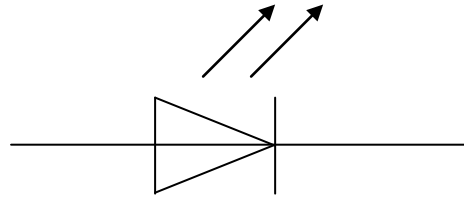

15 The circuit below shows a transistor that switches a light on at nightfall. (N00)

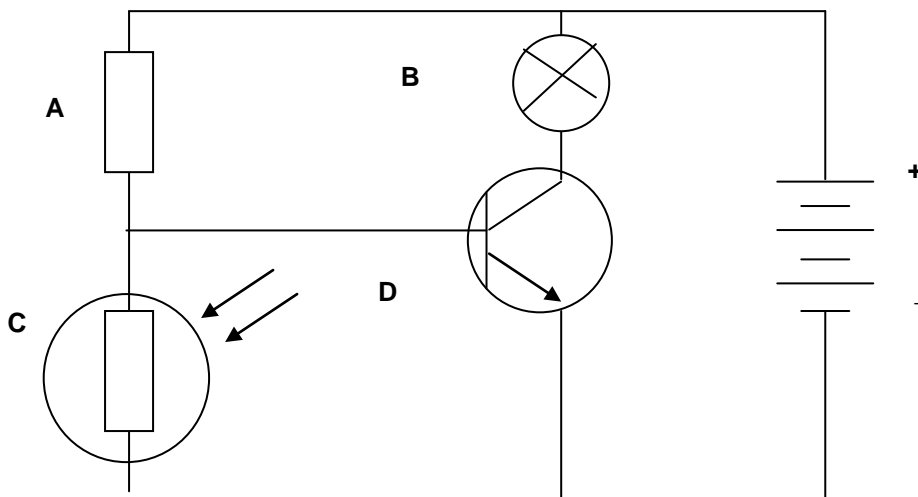

a) Identify each labelled component.

A: **Resistor**

B: **Lamp**

C: **Light – dependent resistor**

D: **NPN Transistor**

b) Describe how the circuit works during the day.

The resistance of the Light - dependent resistor is low, this means the voltage drop across the LDR is low and the voltage across the base emitter is insufficient to turn the transistor on. No current flows from collector to emitter. The light does not go.

- c) Describe how the circuit works during the night.

The resistance of the Light - dependent resistor is high, this means the voltage drop across the LDR is low and the voltage across the base emitter is sufficient to turn the transistor on. No current flows from collector to emitter. The light goes.

- 16 List TWO methods of dissipating the heat produced in a semiconductor device. (J99)

Any two

- Surge diverters
- Snubber circuit
- RC circuit
- Free-wheeling diode

17

- a) Sketch a circuit diagram of a single phase bridge rectifier supplying a resistive load. Show the polarity of the voltage across the load. (J99)

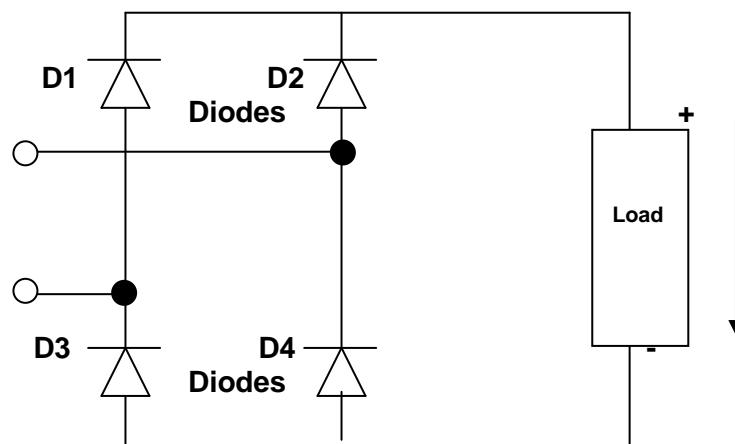

- b) Sketch the input and output waveforms for the above circuit.

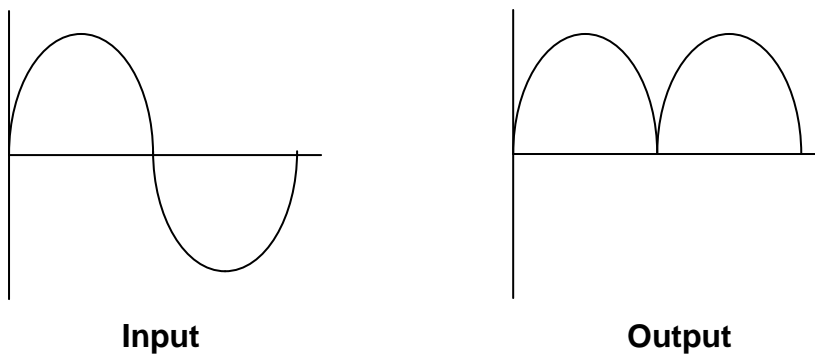

THEORY

- c) If the supply to the above circuit was 14 VAC what minimum peak inverse voltage (PIV) ratings would the diodes require?

$$\begin{aligned} \text{PIV} &= \frac{\text{RMS}}{0.707} \\ &= \frac{14}{0.707} \\ &= \underline{19.8\text{V}} \end{aligned}$$

- d) Sketch simple circuit diagrams to show how an NPN bipolar junction transistor can be used as a :
i) common emitter amplifier.

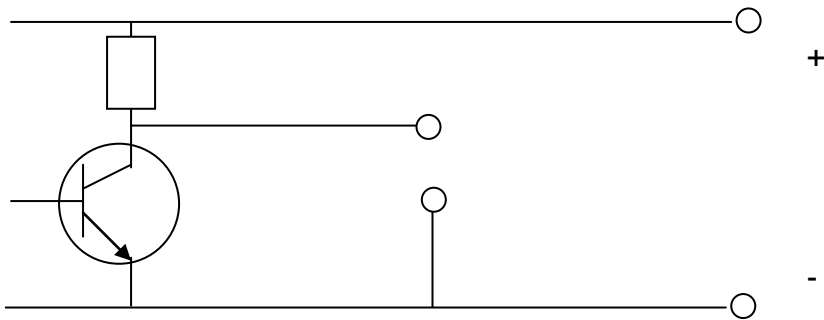

- ii) Switch controlling a lamp.

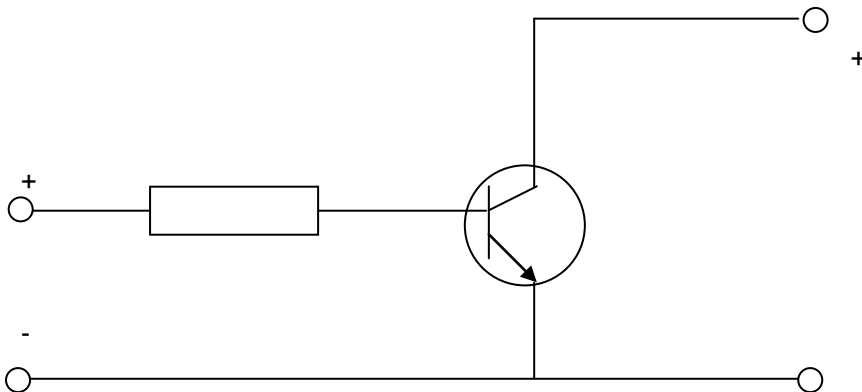

The following are some of the formulas you need to know to do well in your trade exams.

FORMULAE	
$Z^2 = R^2 + X^2$	$V_{rms} = 0.707 \times V_{peak}$
$Z = \sqrt{[R^2 + X_L - X_C]^2}$	$V_{dc} = 0.637 \times V_{peak}$
$Z = \frac{V}{I}$	$T = \frac{1}{f}$
$X_L = 2\pi fL$	$\frac{N_p}{N_s} = \frac{V_p}{V_s} = \frac{I_s}{I_p}$
$X_C = \frac{1}{2\pi fC}$	SOHCAHTOA
$S = \sqrt{P^2 + Q^2}$	$\frac{N_1}{N_2} = \frac{D_2}{D_1}$
$P = \sqrt{S^2 - Q^2}$	$W = m.a.d$
$Q = \sqrt{S^2 - P^2}$	$R = \frac{PI}{A}$
$S = VI$	$Q = CV$
$P = S \cos \Phi$	$W = \frac{1}{2} CV^2$
$Q = S \sin \Phi$	
$P = \frac{V^2}{R}$	$N_s = \frac{F \times 60}{p}$
$P = V \times I \times \cos \Phi$	$\eta = \frac{P_o}{P_i} \times 100$
$Q = P \times \tan \Phi$	$P_o = 2 \times \pi \times N_r \times T$
$PF = \cos \Phi$	$P_i = V \times I \times \cos \Phi$
$PF = \frac{R}{Z}$	$P_o = V \times I \times \cos \Phi \times \text{Eff}$
$T = R \times C$	$S = V \times I$
$T = \frac{L}{R}$	$Q = V \times I \times \sin \Phi$
Peak Volts = $V_{rms} \times \sqrt{2}$	