



## Learning resource

**Demonstrate and apply knowledge of single-phase and three-phase transformers (level 4, credits 4)**

Trainee Name: \_\_\_\_\_

---

This document is strictly confidential, and the contents must not be disclosed to any unauthorised persons or used in any unethical or illegal manner. This document is protected by Copyright Act 1994 © and is not to be copied or reproduced in any form unless written permission is given by The Skills Organisation Incorporated.

# Contents

Using this resource .....	2
Introduction .....	1
Step-up and step-down transformers .....	2
Transformer Rating.....	10
Double Wound Transformer Construction .....	11
Comparison of Shell Type and Core Type Transformers .....	13
Autotransformers.....	14
Step Up.....	14
Step Down .....	15
Compare the Auto-transformer & Double Wound Transformers .....	16
Regulations and Standards.....	19
Standards Relating to Transformers.....	20
Using these Clauses.....	21
Summary .....	21
Efficiency (and Losses) of Transformers.....	22
Stray Losses.....	22
Dielectric Losses.....	22
Copper Losses (Variable).....	23
Iron Losses (Constant) .....	24
Percentage Impedance .....	26
Star Voltage relationship .....	27
Star Current relationship.....	28
Delta Voltage relationship.....	28
Delta Current relationship.....	29
Star / Delta Power Formula .....	29
Using Phase Values .....	29
Using Line Values.....	29
Transformer Configurations.....	30
Transformer Configuration Voltage Calculations .....	31
Transformer Configuration Current Calculations .....	35
Delta-Star Step Down Calculations .....	39
Volt Drop in Windings .....	41

Correcting Volt Drop Due to Increased Load.....	41
Voltage Regulation .....	42
Transformer Tests for Copper and Iron Losses.....	43
Purpose of Three Phase Transformers .....	47
Potential hazards associated with transformers .....	48
Precautions to be observed when working with transformers .....	48

## Using this resource

The following information boxes may be found in this resource.



If there is an important note, or a key idea – they may be written into a box like this.



### Definition

Word

Meaning of word

***f(x)***

### Formula

If there is an important formula, it may appear in a box like this.

$$I = \sqrt{I \div R}$$

# Introduction

This unit standard covers elements around single-phase and three-phase transformer calculations specifically:

- solve problems involving single-phase transformers;
- determine single-phase transformer characteristics by measurement;
- demonstrate knowledge of single-phase transformer applications;
- demonstrate knowledge of three-phase transformer losses;
- demonstrate knowledge of three-phase transformer theory;
- take and verify three-phase transformer measurements; and
- demonstrate knowledge of single-phase and three-phase transformer safety requirements.

## Step-up and step-down transformers

### Voltage ratio and turns ratio

In the perfect transformer, all of the primary flux cuts the secondary winding. The voltage per turn induced in the secondary winding is equal to the voltage per turn of the primary.

That is, if the number of turns in the secondary were double that of the primary, the flux would cut two secondary turns for each primary turn. The induced e.m.f. would then be double the e.m.f. in the primary.

It therefore follows that the ratio of the secondary voltage to the primary voltage is the same as the ratio of the secondary turns to the primary turns.

The ratio of turns is called the turn's ratio, and the ratio of voltages is called the voltage ratio. In an ideal transformer, the voltage ratio would be exactly equal to the turn's ratio. A well-designed transformer usually has a very high efficiency (up to 98% at full load).

The voltage ratio is therefore taken as being equal to the turn's ratio.

#### Formula

*f(x)*

The Voltage Ratio is

$$\frac{V_P}{V_S}$$

and the Turns Ratio is

$$\frac{N_P}{N_S}$$

This means that

$$\frac{V_P}{V_S} = \frac{N_P}{N_S}$$

Where:

$V_P$  = primary voltage

$V_S$  = secondary voltage

$N_P$  = number of primary turns

$N_S$  – number of secondary turns

For example, if  $V_P = 240V$  and  $V_S = 80V$  the voltage ratio would be

$$\frac{V_P}{V_S} = \frac{240}{80} = 3$$

This tells us that there are 3 times as many turns on the primary winding as there are on the secondary. This would be a step-down transformer because the voltage is going down from the primary 240V to the secondary 80V.

In order to produce a transformer like this there would have to be three times as many turns on the primary as the secondary.

If there were 300 turns on the secondary, we would have  $300 \times 3 = 900$  turns on the primary.

Let's have a look at how this would be calculated using the formula  $\frac{V_P}{V_S} = \frac{N_P}{N_S}$

We know

$$V_P = 240V$$

$$V_S = 80V$$

$$N_S = 300 \text{ turns}$$

The formula is

$$\frac{V_P}{V_S} = \frac{N_P}{N_S}$$

So, we have

$$\frac{240}{80} = \frac{N_P}{300}$$

Because we want the answer for  $N_P$ , we take the 300 to the other side of the formula and multiply it on that side. This is because when we take a number or letter from one side of the equation it does the opposite on the opposite side.



The rule is '**Change the side, change the sign**'.

The formula then becomes

$$\frac{(240 \times 300)}{80} = N_P$$

We can re-write it as

$$N_P = \frac{(240 \times 300)}{80}$$

$$N_P = \mathbf{900 \text{ turns}}$$



## Example 2

A spot-welding transformer has 1000 primary turns and two turns on the secondary winding. Calculate the secondary voltage when the primary winding is connected to a 400 V supply.

We know:

$$V_P = 400V$$

$$V_S = ?$$

$$N_P = 1000 \text{ turns}$$

$$N_S = 2 \text{ turns}$$

Just looking at the numbers of turns on the primary and secondary we can see that this transformer is going to step down the voltage by a big number. There are only 2 turns on the secondary so the voltage is going to be very low.

We can use the same formula

$$\frac{V_P}{V_S} = \frac{N_P}{N_S}$$

So, we have

$$\frac{400}{V_S} = \frac{1000}{2}$$

If the 'thing' you need to find is on the bottom of the equation like our  $V_S$  is at the moment, it is easier to turn both sides upside down. This would give us

$$\frac{V_S}{400} = \frac{2}{1000}$$

We can then take the 400 across to the other side and make it do the opposite to what it is doing on the left-hand side. At the moment it is dividing and so when we take it across it multiplies. So, we get:

$$V_S = \frac{(2 \times 400)}{1000} = 0.8V$$

This is a very low voltage as we suspected with the turns ratio being 1000 to only 2. We will look at current a bit later, but this is a good example of a transformer being used to produce a tiny voltage and a huge current to strike an arc for welding. The voltage has gone down by  $(1000 / 2) = 500$  times and so to balance this out the current will go up 500 times. Even with a tiny current from the supply of say 0.1 A this would give a welding current of  $0.1 \times 500 = 50A$

### Example 3

A 235 V to 90 V step down transformer has a primary winding of 2500 turns. It has a 30 Ω load connected to the secondary.

We are going to calculate the number of secondary turns and the current flowing in the secondary and primary windings.

We know

$$V_P = 235V$$

$$V_S = 90V$$

$$N_P = 2500 \text{ turns}$$

$$N_S = ?$$

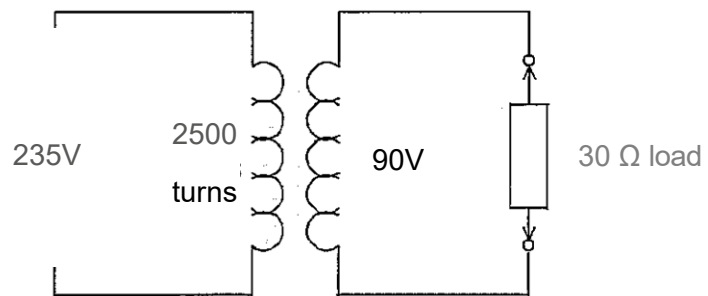

We can use the same formula:  $\frac{V_P}{V_S} = \frac{N_P}{N_S}$

$$\frac{235}{90} = \frac{2500}{N_S}$$

Again, the one we want to find is on the bottom of the formula, so turn both sides upside down to get:

$$\frac{90}{235} = \frac{N_S}{2500}$$

All we need to do now is to take the 2500 to the other side and multiply it

$$\frac{(90 \times 2500)}{235} = 957.45 \text{ turns}$$

We can't have 0.45 of a turn and so we would generally call this 958 turns.

We are now going to calculate the current flowing in the secondary winding.

We will use basic Ohm's Law which is

$$I = \frac{V}{R}$$

We get

$$I = \frac{90}{30} = 3A$$

The current flowing in the primary can be found using a similar ratio formula to the turns and voltage ratio.

That is

$$\frac{I_P}{I_S} = \frac{V_S}{V_P} \text{ (notice that primary is on top for current)}$$

$$\frac{I_P}{3} = \frac{90}{235}$$

In order to find  $I_P$  we just take the 3 to the other side and multiply it

$$I_P = \frac{90 \times 3}{235} = 1.15A$$

All three ratios can be combined into one formula to give us

$$\frac{V_P}{V_S} = \frac{N_P}{N_S} = \frac{I_P}{I_S}$$

Notice again that if the voltage and turns have primary on top, current will have secondary on top. The reverse is also true and can be used

$$\frac{V_S}{V_P} = \frac{N_S}{N_P} = \frac{I_S}{I_P}$$

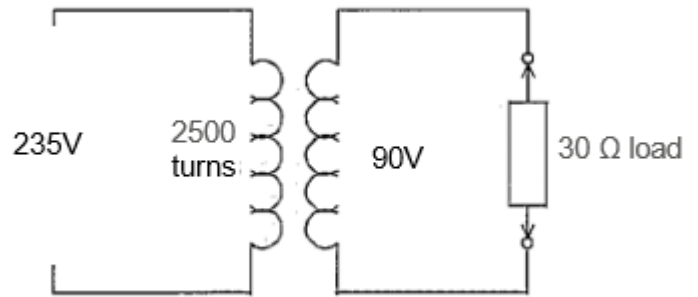

### Example 4

A 235 step down transformer has a step-down ratio of 20:1 and is used to supply an electric toy. The transformer has 3000 turns on the primary and is rated at 30VA.

We are going to calculate the maximum primary current and the number of secondary turns.

This example introduces the idea of VA. This gives us an indication of the maximum current that the transformer can handle.

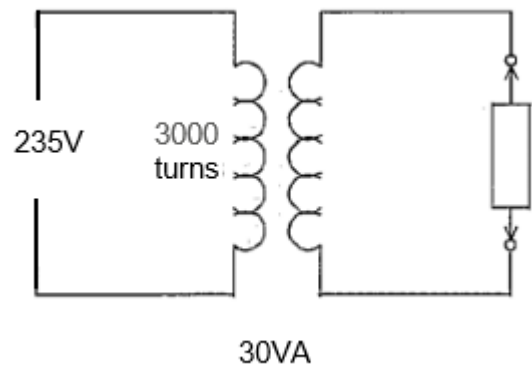

VA is just Volts x Amps

$$VA = V \times I$$

So, if we re-arrange the formula for I we get

$$I = \frac{VA}{V}$$

The maximum current will be the VA rating divided by the voltage

We want to find the maximum primary current so that will be

$$I = \frac{VA}{V}$$

$$I = \frac{30VA}{235V}$$

$$I = 0.13A$$

This means that if the transformer takes more than 0.13 A it will overheat and could become damaged because it would be going above its 30VA rating.

We now need to find how many turns are on the secondary winding.

We are told it has a step down ratio of 20:1. This means that the voltage will go down by 20 and the turns will go down by 20. (current will go up by 20 because in a transformer it does the opposite to the voltage)

The number of turns in the primary is 3000 and so there will be 20 times less in the secondary

$$N_S = \frac{N_P}{\text{Turns ratio}}$$

$$N_S = \frac{N_P}{20}$$

$$N_S = \frac{3000}{20} = 150 \text{ turns}$$

We can find the secondary voltage in a similar way

$$V_S = \frac{V_P}{\text{Turns ratio}}$$

$$V_S = \frac{235}{20}$$

$$V_S = 11.75 \text{ V}$$

We can find the maximum secondary current now that we know the secondary voltage, using the VA rating

$$I = \frac{VA}{V}$$

$$I = \frac{30VA}{11.75V}$$

$I = 2.55\text{A}$  (notice that there is a higher secondary current because the secondary voltage is lower than the primary)

The last thing we can find is the volts per turn of the transformer. We can use either the primary or the secondary figures. They will both give the same answer.

$$\text{Volts/turn (primary)} = V_P / N_P = 235 / 3000 = \mathbf{0.0783 \text{ V/turn}}$$

$$\text{Volts/turn (secondary)} = V_S / N_S = 11.75 / 150 = \mathbf{0.0783 \text{ V/turn}}$$

## Transformer Rating

We have seen in the previous examples that transformers are rated in VA and not watts.

The VA rating tells us the maximum current for a given voltage. If the VA is 100 and the voltage is 25V we know that the maximum current the transformer can handle would be 4A ( $100\text{VA}/25\text{V}$ )

If transformers were only used for resistive loads then we could rate them in Watts but when they are used for reactive (inductive generally) loads, it introduces a power factor which means that the VA and the Watts values are not the same.

### Resistive Loads

With resistive loads, which cause no current phase displacement, there is no numerical difference between watts and VA because the power factor is 1.

### Reactive Loads

With reactive loads there is a current displacement and the power factor drops, meaning that the power (Watts) is now lower than the apparent power (VA).

For instance, a 100 VA transformer supplying a reactive load cannot deliver 100 W because of the power factor. If the power factor was 0.5 it would only be able to deliver  $100/0.5 = 50\text{W}$ .

When the manufacturer supplies the transformer, they do not know the power factor of the load is going to supply and so it has to be rated in VA.

## Double Wound Transformer Construction

Cores are laminated cold rolled grain orientated silicon steel, lightly varnished to minimise eddy current losses. Cores are bolted together or held together with fibre glass binders. The vertical portions of the core laminations make up the limbs. The top and bottom irons are called yokes.

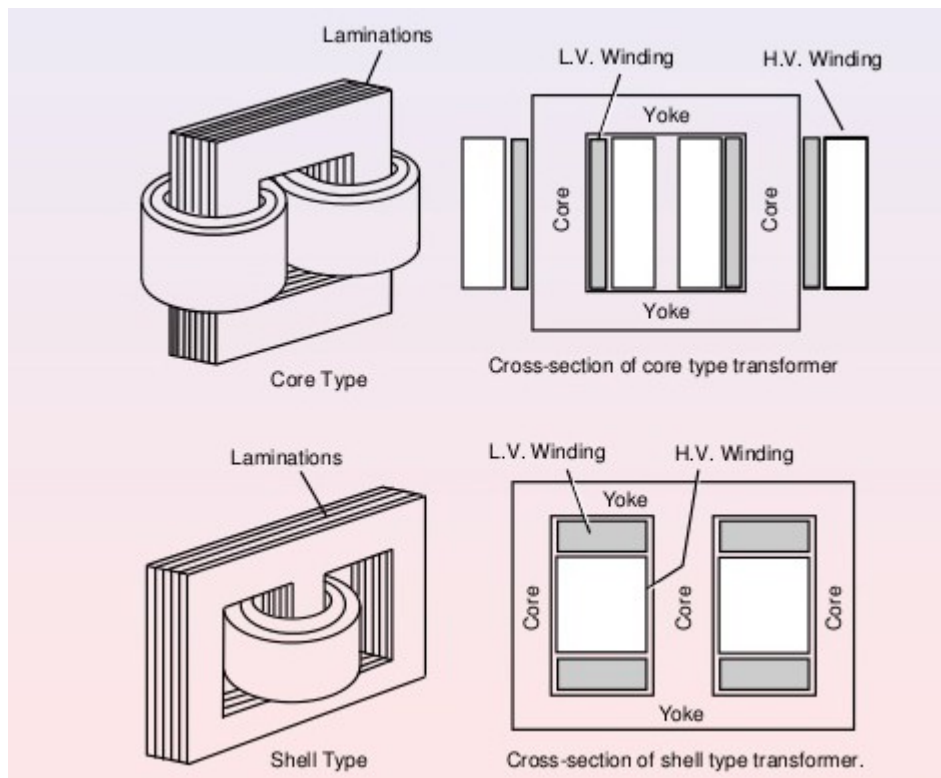

### The Shell type core

This construction has three limbs, the centre limb being of a greater cross-sectional area than the outer limbs. Both primary and secondary windings are placed over the centre limb, no windings being on the outer limbs (refer to later picture).

Large power transformers use all the limbs.

### The Core type core

This transformer has just two limbs. Primary and secondary windings being distributed on both limbs. Half the primary and half the secondary turns are wound on one limb, and the other half of the primary and secondary turns are wound on the other limb. They are usually wound concentrically with the low-voltage winding next to the core (refer to later picture).

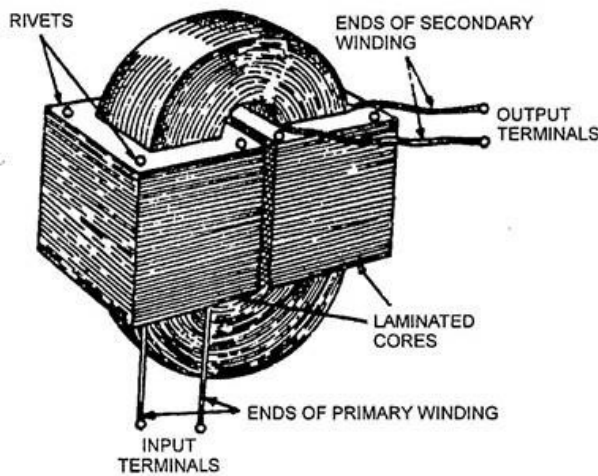

**Core Type**

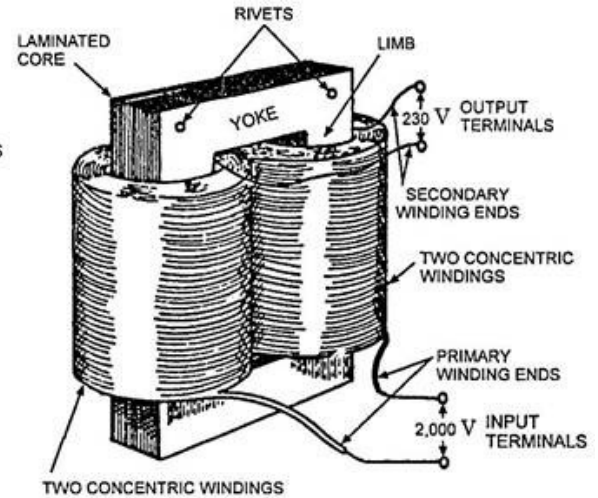

**Shell Type**

The windings of the transformers are either copper or aluminium wire and insulated by cotton, paper, varnished cambric, or simply enamelled in small transformers. Additional insulation is provided between the coils and between the coils and core. This insulation may be pressboard or synthetic resin-bonded cylinders in large transformers, and varnished cambric is sometimes used in small ones.

Specific shapes of irons are used to make up the core. In the Shell type transformer below, the primary and secondary windings are wrapped around an 'E' shaped iron, and then an 'I' shaped iron is attached to complete the assembly (called and E-I lamination) alternatively and E-E lamination is used.

In the Core type transformer, the primary winding is usually wrapped around a 'U' shaped iron, and then an 'I' shaped iron is attached to complete the assembly (called a U-I lamination. Less often, an L-L lamination is used.

Shell-type Laminations

Core-type Laminations

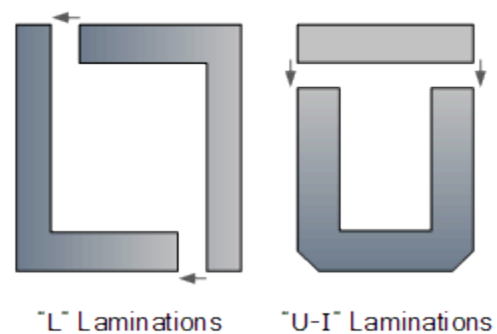
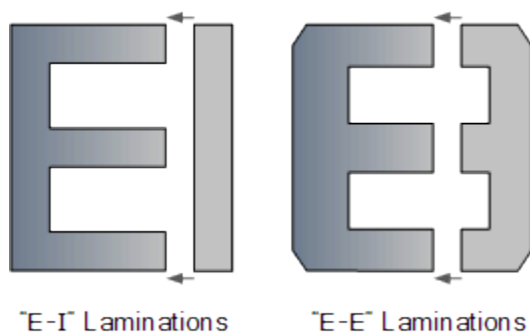



Power transformers are frequently oil cooled. The open basket weave winding allows transformer oil to act both as a coolant, and as secondary insulation. In areas of high fire risk, transformers may be filled with insulating liquids other than oil (eg, Pyronal) or may even be air cooled.

The low-tension coil is usually placed close on the transformer iron limb. The high-tension winding is on top of it with suitable high-quality insulation between the windings.

## Comparison of Shell Type and Core Type Transformers

Core type transformer	Shell type transformer
<ul style="list-style-type: none"> <li>➤ The core has only <b>one</b> window</li> <li>➤ <b>Windings</b> encircle the core</li> <li>➤ <b>Cylindrical</b> windings are used</li> <li>➤ It is <b>easy</b> to repair</li> <li>➤ <b>Better cooling</b> since more surface is exposed to the atmosphere</li> <li>➤ Less mechanical protections to the coil</li> <li>➤ The construction is preferred for low voltage transformers</li> </ul>	<ul style="list-style-type: none"> <li>➤ The core has <b>two</b> windows</li> <li>➤ <b>Core</b> encircles the windings</li> <li>➤ <b>Sandwich</b> windings are used</li> <li>➤ It is <b>not so easy</b> to repair</li> <li>➤ Cooling is <b>not very effective</b></li> <li>➤ Better mechanical protection to the coils</li> <li>➤ The construction is preferred for high voltage transformers</li> </ul>

# Autotransformers

This is a special type of transformer used for a small step-up or step-down of voltage. It is a transformer with only one winding, as shown below, with an iron-cored coil and having a large inductance.

## Step Up

The input voltage tapplings are shown in Figure (a).  $P_1 P_2$  are the primary terminals, and  $S_1 S_2$  the secondary terminals. If a supply voltage is applied to the primary terminals, its voltage will be balanced by the back e.m.f. of the turns  $N_1$ , (between terminals  $P_1$  and  $P_2$ ). The flux created due to the primary current will thread the whole coil of  $N_2$  turns, and consequently the potential difference between the secondary terminals ( $S_1$  and  $S_2$ ) will be greater than the supply voltage in the proportion of  $N_2/N_1$ , or the transformation ratio –  $T$ .

If a load is joined across the secondary terminals, a current  $I_2$  will flow in the secondary circuit.

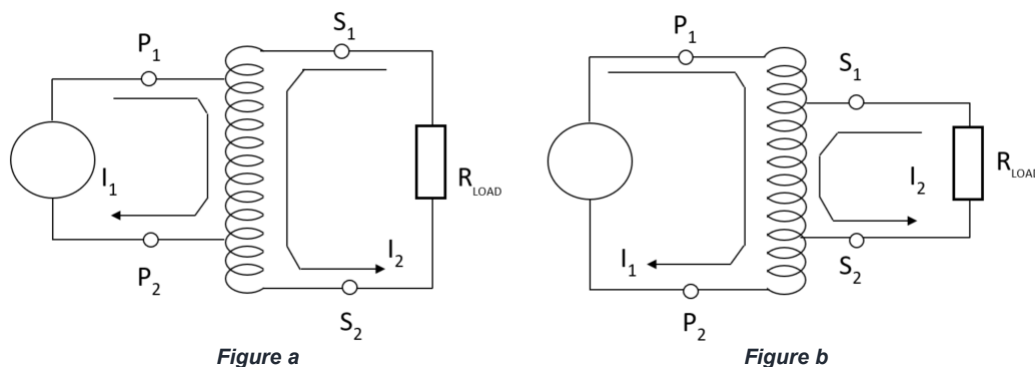

In the same way as the double wound transformer, the secondary current must be counterbalanced by a current  $I_1$  in the primary, so  $I_1 = I_2 \times T$ . Neglecting losses,  $I_1$  can be taken to be the whole primary current.

Furthermore,  $I_1$  and  $I_2$  are  $180^\circ$  out of phase.

### Formula

$f(x)$

Therefore, as shown in the figure above, the current in the common portion of the winding is given by:

$$I_3 = I_1 - I_2$$

---

## Step Down

The transformer would be used in the configuration shown in Figure (b) above.

Typical applications for autotransformers include starting for induction motors, where they reduce the applied voltage during start up. They are also used to preheat the electrodes in an instant start fluorescent lamp. Step-up auto-transformers are used as boosters near the ends of long transmissions lines where line losses have caused the voltage to drop a little lower than permissible.

## Compare the Auto-transformer & Double Wound Transformers

It can be shown that there is a considerable saving in the amount of copper and in the copper losses with an auto-transformer as compared with a double wound transformer, but this saving diminishes rapidly as the transformation ratio  $T$  increases. Hence, an auto-transformer is only suitable for a small step-up or step-down of voltages.

Its great disadvantage is that there is direct electrical connection between the primary and secondary circuits. If a break occurs in the winding between  $S_1$  and  $S_2$  in a step-down transformer, the higher primary voltage is applied to the low-tension load. This is another reason for limiting the utility of the auto-transformer to cases where  $T$  is small. In addition, part of the winding has to be thick enough to stand the primary current, and the whole well enough insulated to stand the secondary voltage.

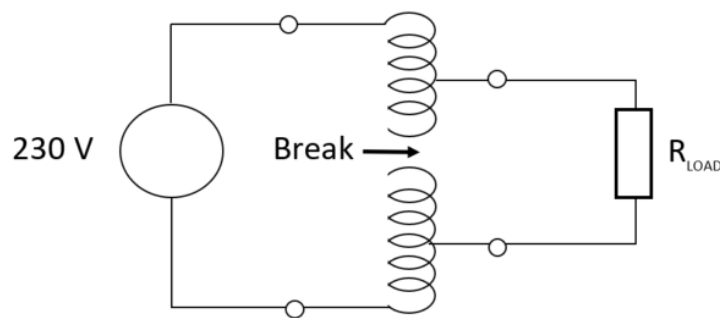

### Advantages

- Its efficiency is higher when compared with a conventional one.
- Its size is relatively much smaller, therefore needing less space.
- Voltage Regulation of autotransformer is much better.
- Simpler to construct and lower cost
- Low requirements of excitation current.
- Less copper is used in its design and construction.
- In conventional transformer the voltage step-up or step-down value is fixed while in auto transformer, we can vary the output voltage as per our requirements and can smoothly increase or decrease its value as per our requirement.

### Disadvantages

- Lack of electrical isolation because of the common connection
- Potential for high voltages to appear across the secondary.

For these reasons, an iron-cored autotransformer is not commonly used in electronics for alternating currents, but the principle is an important one to understand, as it often comes in when considering, for example, how to join aerials in oscillating circuits, and in many other cases.

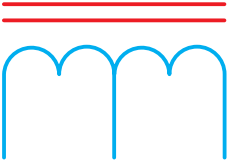
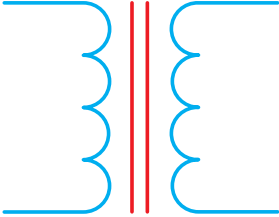
Basis for Differences	Autotransformer	Double Wound
Definition	A transformer, having only one winding a part of which acts as a primary and the other as a secondary.	It is a static machine, which transfers electrical energy from one end to another without changing frequency.
Mechanical Construction	Single Winding Auto-transformer has only one winding wound on a laminated core	Double Winding It has two separate winding, i.e., primary and secondary winding.
Symbol		
Insulation	The primary and secondary winding are not electrically insulated.	The primary and secondary winding are electrically insulated from each other.
Induction	Self-Induction	Mutual Induction
Physical Size	Small for same size as has only one winding	Larger for same size as has two separate windings
Power Transfer	Partly by transformation and partly by direct electrical connection.	Through transformation
Voltage Regulation	Better	Good
Winding Material	Requires less	Requires more
Electrical Isolation	Common Connection The primary and secondary winding circuits are connected both electrically and magnetically.	Isolation Provided The primary and secondary winding circuits are connected magnetically.
Connection	Depends upon the tapping	Connect directly to the load.

Basis for Differences	Autotransformer	Double Wound
Starting current	Decreases	Decreases by 1/3 times.
Excitation current	Small	Large
Economical	More	Less
Cost	Can be more expensive in some instances because of complex construction	Can be cheaper than auto transformer depending on the application
Efficient	More	Less
Leakage flux and resistance	Low	High
Impedance	Less	High
Complexity	Complex construction	Simple construction
Losses	Low	High
Output voltage	Variable	Constant.
Applications	Use as a starter in an induction motor, as a voltage regulator, in railways, in a laboratory.	Use in power system for step up and step down of voltage.

# Regulations and Standards

Whenever working with or installing transformers we must be aware of the fact that the Electricity Regulations 2010 stipulates particular standards for transformers. These can be found in Schedule 4 – Standards applicable to fittings and appliances; Section 14.

AS/NZS 3000:2007 (soon to be updated) also makes particular reference to transformers and their installation. The following are of particular importance:

- ▶ extra-low voltage circuits,
- ▶ electric toys,
- ▶ medical and dental apparatus,
- ▶ high-voltage discharge lamps, and
- ▶ restrictions for auto-transformers.

## Standards Relating to Transformers

### AS/NZS 3000:2007

#### Voltage values

The wiring rules sets out the definitions for Extra-low voltage, low voltage and high voltage

(1.4.98)

- Extra Low Voltage is a voltage not exceeding **50V a.c. or 120V** ripple free d.c.
- Low Voltage is a voltage exceeding extra-low voltage, but not exceeding **1000V a.c. or 1500V d.c.**
- High Voltage is any voltage exceeding low voltage.

It also says in 4.14.4 that autotransformers shall not be used to supply equipment having a voltage rating of less than the highest input or output voltage of the auto transformer.

### AS/NZS 62115:2018

#### Toys

gives specific instructions in 3.4.2 (transformers for toys) that transformers for toys shall be safety isolating transformers specially designed to supply toys operating at safety extra-low voltage not exceeding 24V a.c. or d.c.

It also says, in 3.4.3, that the input winding is electrically separated from the output winding by insulation at least equivalent to double or reinforced insulation, which provides a supply at safety extra-low voltage.

### AS/NZS 3832

#### Lighting Circuits

Autotransformers cannot be used for supplying electric toys or high voltage lighting circuits. AS/NZS 3832 says that auto transformers shall not be used to supply the high voltage circuits of cold cathode illumination systems. This can be found in 3.3.2

### AS/NZS 3003:2011

#### Medical Areas

Like all electrical equipment, transformers should not adversely affect the surrounding area. AS/NZS 3003:2011 says in 2.9.2, that transformers installed in medical areas, shall be installed to ensure the temperature of the space or enclosure does not exceed its maximum ambient temperature. It also says that an autotransformer can only supply one patient area in a cardiac protected area but may supply more than one in a body-protected area.



## Using these Clauses

Understanding the intent of these clauses above is one thing, however you should read the clauses highlighted in red to understand what impact they have on the mentioned clause above. It may add additional information or requirements; or it may provide additional exceptions.

## Summary

- The secondary of the transformer must comply with the requirements of the standard for ELV, LV and HV as appropriate for the nominal secondary voltage.
- The secondary conductors of transformer must be considered as a sub-main or final circuit and therefore must be protected and controlled appropriately.
- If there is only one circuit connected or supplied and the conductors have a current carrying capacity of not less than the rated load current of the transformer primary winding multiplied by the turns ratio of the primary to secondary voltage then over current protection of the secondary winding circuit is not required.
- For isolating transformers any connected equipment shall ensure correct protection by electrical separation and isolation from each part in accordance with **Clause 1.7.4.5**.
- For low voltage transformers where the output does not meet AS3108, the equipment is required to be earthed in accordance with **Clause 5.4** (earthing requirements). This basically means that any exposed electrical conductive parts must be earthed.
- Auto transformers must be insulated for the highest input or output voltage that the autotransformer is capable of.
- Step-up transformers – where the transformer is used to increase the voltage above that at which the electricity supplying it then no connection other than that made by an earthing conductor shall be made between the primary and secondary windings.

# Efficiency (and Losses) of Transformers

The efficiency of a transformer is simply the output power divided by the input power. Furthermore, the input power can be described as being equal to the output power plus any losses within the transformation process, i.e.:

$$\begin{aligned} \text{Efficiency} &= \text{Power Out} \div \text{Power In} \\ &= \text{Power Out} \div (\text{Power Out} + \text{Losses}) \end{aligned}$$

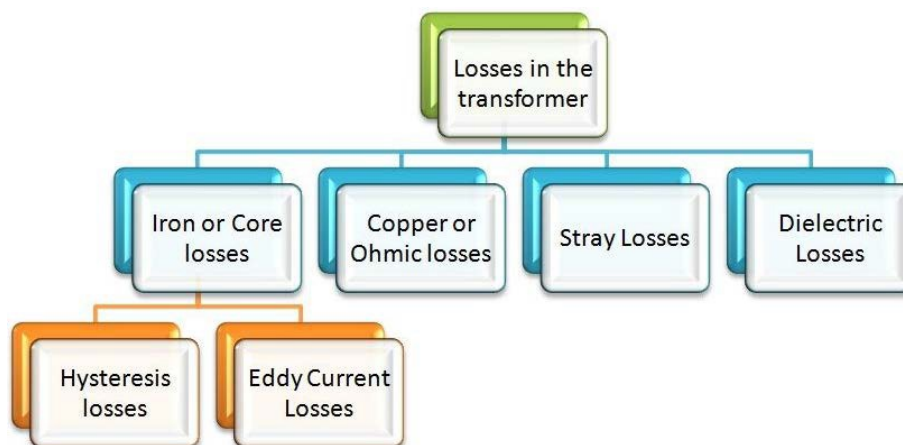

All we need to know now is, what are the losses?

Losses can be divided into four discrete groups as you can see above.

## Stray Losses

The occurrence of these stray losses is due to the presence of leakage field. The percentage of these losses are very small as compared to the iron and copper losses so they can be ignored.

## Dielectric Losses

Dielectric loss occurs in the insulating material of the transformer i.e. in the oil of the transformer, or the solid insulation. When the oil deteriorates or the solid insulation get damaged or its quality decreases, the efficiency of transformer is affected

## Copper Losses (Variable)

These losses are due to the 'true power losses' within the transformer brought about by the resistance of both the primary and secondary windings. As the current flows through these windings,  $I^2R$  losses occur.

Because these losses are related to the current flowing in the windings, they are variable and will vary with the load.

An increase in load current will increase the copper losses. They will increase by the square of the current because

Copper Loss (variable) is proportional to  $I^2$

Copper loss in a winding is equal to  $I^2R$

For example, the copper loss in a winding having a resistance of  $0.5\Omega$  and a current flow of 5 A would be:

$$\text{Copper loss} = I^2R = 5^2 \times 0.5 = 12.5W$$

If we doubled the current to 10A you might expect the copper loss to double but it will actually increase by 4 times.

$$\text{Copper loss} = I^2R = 10^2 \times 0.5 = 50W$$

So, in summary, Copper Losses are **variable**, and they vary with the **load**. They are **proportional to current squared** and can be calculated by  $I^2R$

## Iron Losses (Constant)

The name 'iron losses' is given to describe the **constant losses** of a transformer. They occur in the iron or steel core of the transformer. These losses **do not vary** with the load.

There are two specific types of iron losses

- Hysteresis losses
- Eddy Current losses

### Hysteresis losses

As the iron core is magnetised and demagnetised, the magnetic domains are aligned in one direction, and then re-aligned in the opposite direction. Finally, the domains are aligned back to the original polarity.

Hysteresis loss is the energy used to constantly realign the magnetic domains. It is used even when the transformer is not loaded.

This energy appears as heat in the specimen and is referred to as 'hysteresis loss'. This loss is proportional to the area contained within the hysteresis curve of the metal being magnetised, and to the supply frequency.

### Reducing Hysteresis

Hysteresis can be reduced by changing the core material.

Low loss silicon steel is used because this has very low hysteresis loss

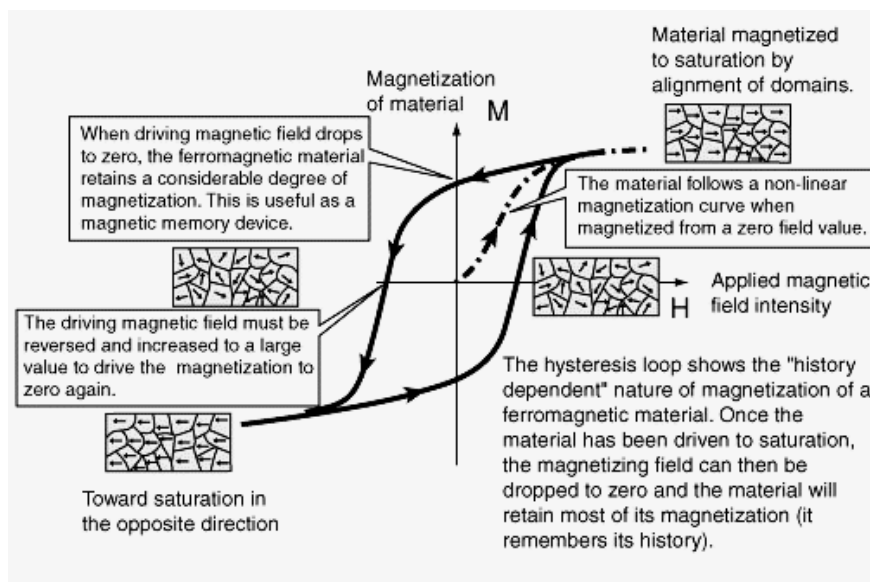

## Eddy current losses

As the magnetic field around the iron core expands and contracts every cycle, the total flux cuts the iron core, and induces into it an emf. This emf causes a circulating current to flow at right angles to the iron core.

As the magnetic path is usually made of an electrically conductive material, very large currents, and therefore  $I^2R$  losses, would result in the iron core.

## Reducing Eddy Currents

This problem of eddy current losses is dramatically reduced by laminating the core. That is, by making the magnetic core out of many layers.

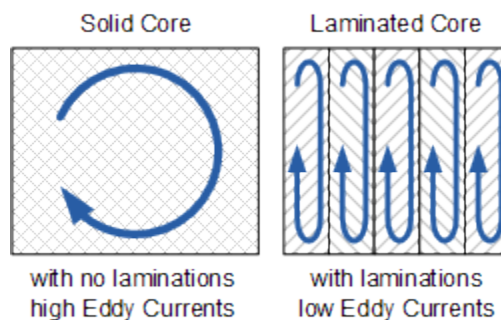

Each layer is then insulated, and then the complete assembly is bolted together. The resulting core is now an electrical insulator (between laminations), whilst maintaining its magnetic conductivity.

Another method employed in reducing eddy current losses is to use a silicon-iron alloy, usually about 4% of silicon, due to the resistivity of this alloy being much higher than that of ordinary iron.

## Percentage Impedance

If a short circuit fault between phases occurs in a three-phase transformer the fault current will be extremely **high**.

It will be limited only by the VA rating of the transformer and its percentage **impedance** (Z%).

As Z (impedance) is generally very low (around 5%), the fault current is going to be extremely high.

In order to calculate the fault current, we can calculate the maximum current rating of the transformer and then divide it by the impedance (Z)

### Example

If we had a 300 kVA 400V 3 phase transformer the maximum current would be

$$I_{MAX} = \frac{VA}{\sqrt{3} \times V_L}$$

$$I_{MAX} = \frac{300000}{\sqrt{3} \times 400} = 433A$$

The fault current that would flow would depend on Z.

Let's say that Z = 6% (0.06)

$$I_{FAULT} = \frac{I_{MAX}}{0.06} = 7217A$$

Alternatively, we can carry out the calculation in one step

$$I_{FAULT} = \frac{VA}{(\sqrt{3} \times V_L \times Z)}$$

$$= \frac{300000}{(\sqrt{3} \times 400 \times 0.06)} = 7217A$$

## Star Voltage relationship

### Star Line and Phase relationship

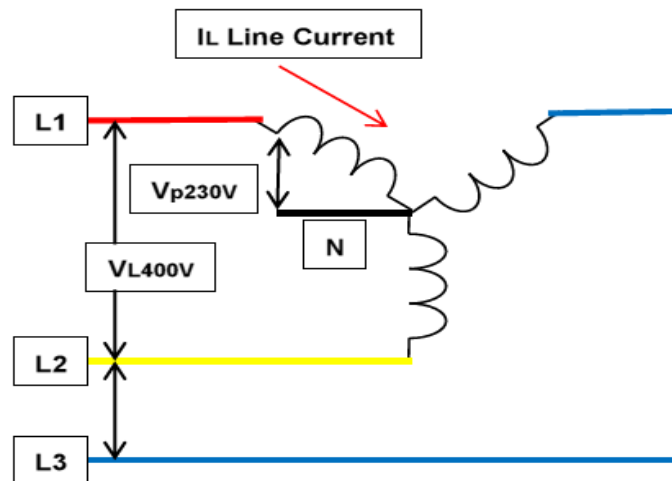

If the windings of a three-phase transformer are connected in Star there will be a number of different voltages present. The diagram above shows the arrangement and the relationship of the voltages

In this example, across the lines (that is between pairs of red, yellow and blue) there is 400V. This is known as the line voltage. The line voltage in a Star configuration is always greater than the phase voltage. You can see in the diagram above that the voltage between red and yellow (400V) is across 2 of the star windings. Those two windings must 'share' the 400V. You might expect the voltage across the two to be 200V (half each) but in a three-phase system the value is found by

$$V_{Phase} = V_{Line} / \sqrt{3}$$

The voltage across the phase is the voltage across the line divided by the square root of 3. Similarly, the voltage across the line  $V_{Line}$  is the phase voltage multiplied by the square root of 3.

$$V_{Line} = V_{Phase} \times \sqrt{3} \text{ abbreviated to } V_L = \sqrt{3} V_{Ph}$$

## Star Current relationship

The current flowing in the line is the same current that flows in the phase. If we trace the red current into the winding, it will go through the winding to either the neutral (if there is one) or through the other two windings. The current that flows in the winding is the same as the current that flowed in from the line. So, we can say that:

$$I_{\text{Line}} = I_{\text{Phase}} \quad \text{abbreviated to} \quad I_L = I_{Ph}$$

## Delta Line and Phase relationship

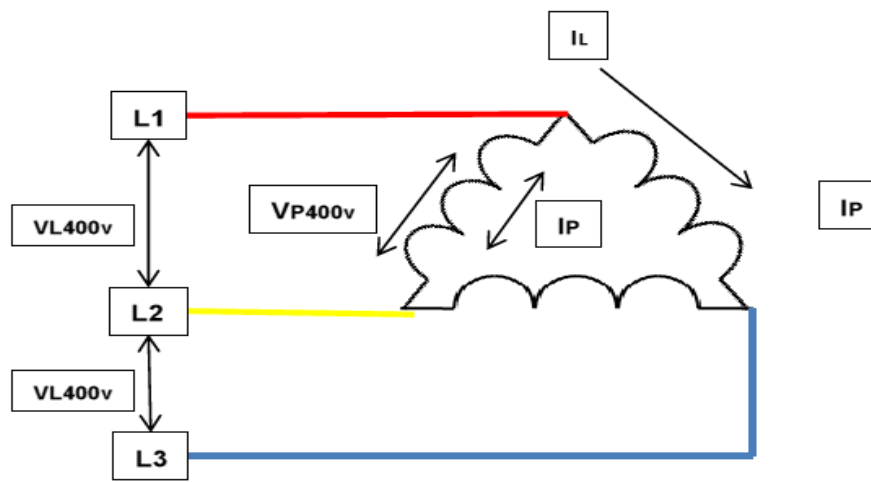

## Delta Voltage relationship

In a Delta system the voltage that is across the lines (in pairs between red, yellow and blue) also appears straight across the phase. In the diagram above you can see that the line voltage between red and yellow is directly connected to the winding. Therefore, we can say that:

$$V_{\text{Phase}} = V_{\text{Line}} \quad \text{abbreviated to} \quad V_{Ph} = V_L$$

If there is 400v across the line, then there is 400V across the phase.



## Delta Current relationship

The current is now different in the phase and the line. The current flowing in the line (say the red phase) is now split between two windings. Look at the red connection at the top of the drawing. It splits between two windings. Just as the voltage in Star did not just divide by two, the current in a delta system doesn't either. It reduces by the same factor – Root three ( $\sqrt{3}$ ). The line current is therefore root three ( $\sqrt{3}$ ) bigger than the phase current. We can say that:

$$I_{Line} = I_{Phase} \times \sqrt{3} \text{ abbreviated to } I_L = \sqrt{3} I_P$$

## Star / Delta Power Formula

The power (S) measured in VA, in a transformer can be calculated in two ways.

- Using phase values
- Using line values

Both calculations will give you the same, correct answer.

### Using Phase Values

We can find the power in one winding and multiply it by three.

The power (S) in one winding is a product of voltage and current

$$S = V_{Phase} \times I_{Phase} \text{ abbreviated to } S = V_{Ph} \times I_{Ph}$$

The power (S) in the three windings will therefore be:

$$S = 3 \times V_{Phase} \times I_{Phase} \text{ abbreviated to } S = 3 V_{Ph} I_{Ph}$$

### Using Line Values

The formula for finding the power (S) in a transformer using line values is

$$S = V_{Line} \times I_{Line} \times \sqrt{3} \text{ abbreviated to } S = \sqrt{3} V_L \times I_L$$

This formula applies to both Star and Delta configurations. As long as the line values (**V<sub>L</sub>** and **I<sub>L</sub>**) are used it will find the total power of the transformer in VA

# Transformer Configurations

Three Phase Transformers can be connected in four main different ways. They are

## Star / Star

Primary and secondary both connected in Star



Star connection

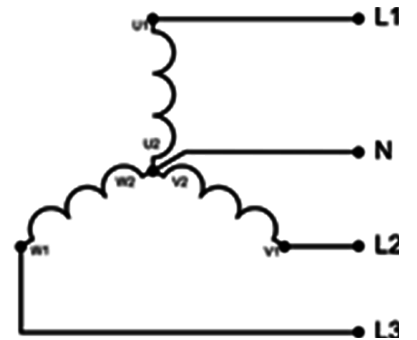

## Star / Delta

Primary is in Star and the secondary is in Delta

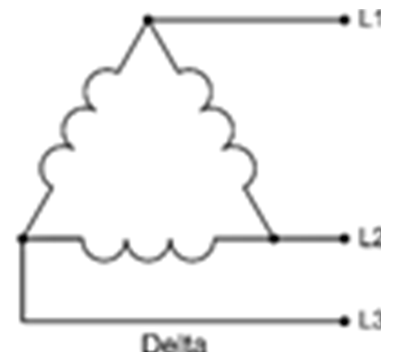

## Delta / Star

Primary is in Delta, secondary in Star

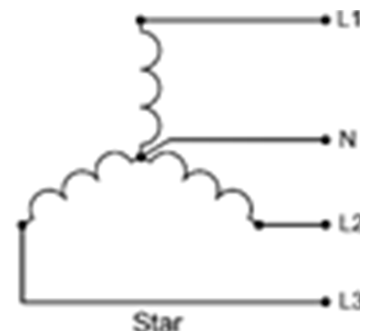
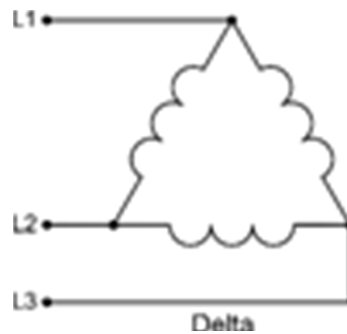

## Delta / Delta

Both the primary and Secondary are connected in Delta.

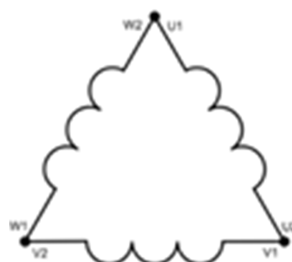

Delta connection

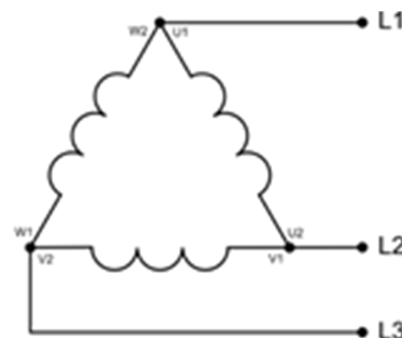

## Transformer Configuration Voltage Calculations

The different connections are going to change the current and voltages within the system, even with the same input voltage.

Let's look at an example that has a 360V input voltage (input is always the line voltage) and a turns ratio of 3:1 (turns ratio is always between the phase values)

We'll find the line voltage on the secondary for all four configurations

### Delta/Delta

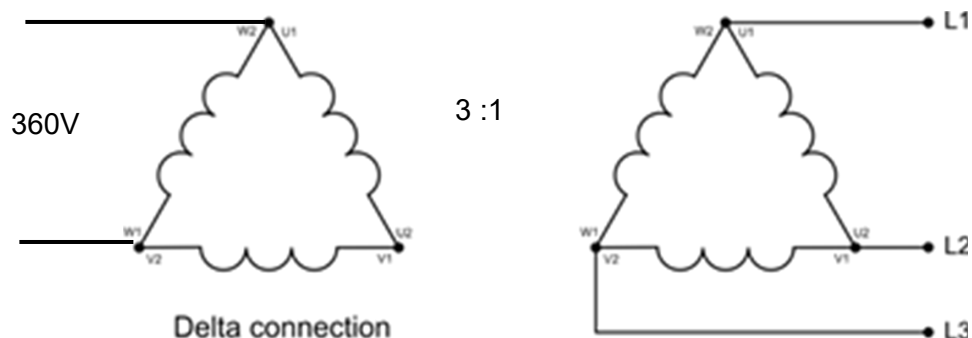

#### Primary

$$V_P = V_L$$

*Phase voltage is equal to line voltage*

$$V_P = 360V$$

*We will see 360V across each winding of the primary*

#### Secondary

$$V_{P(\text{secondary})} = \frac{V_{P(\text{Primary})}}{3}$$

*Divide the primary voltage by the ratio*

$$V_{P(\text{secondary})} = \frac{360}{3} = 120V$$

*Secondary phase voltage is 120V*

In Delta the line voltage equals the phase voltage so:

$$V_{L(\text{secondary})} = V_{P(\text{secondary})}$$

*They are equal*

$$V_{P(\text{secondary})} = 120V$$

*Line voltage on the secondary is 120V*

## Delta/Star

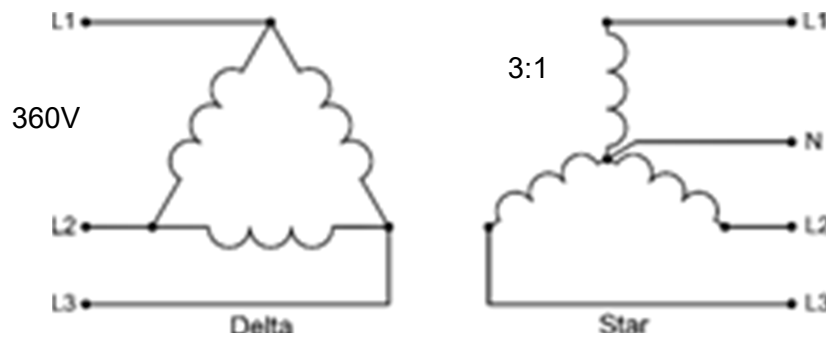

### Primary

$$V_P = V_L$$

*Phase voltage is equal to line voltage*

$$V_P = 360V$$

*We will see 360V across each winding of the primary*

### Secondary

$$V_{P(\text{secondary})} = \frac{V_{P(\text{Primary})}}{3}$$

*Divide the primary voltage by the ratio*

$$V_{P(\text{secondary})} = \frac{360}{3} = 120V$$

*Secondary phase voltage is 120V*

In Star the line voltage will be  $\sqrt{3}$  bigger than the phase voltage, so:

$$V_{L(\text{secondary})} = V_{P(\text{secondary})} \times \sqrt{3}$$

*Line voltage is root three bigger*

$$V_{L(\text{secondary})} = 120V \times \sqrt{3}$$

*Line voltage 120V times root three*

$$V_{L(\text{secondary})} = 207.85V$$

## Star / Delta

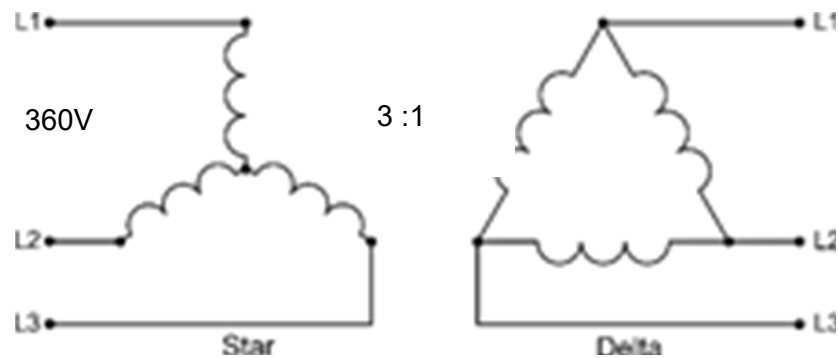

### Primary

$$V_P = \frac{V_L}{\sqrt{3}}$$

*Phase voltage is root three smaller than line voltage*

$$V_P = \frac{360}{\sqrt{3}}$$

*360V divided by the square root of three*

$$V_P = 207.85V$$

### Secondary

$$V_{P(\text{secondary})} = \frac{V_{P(\text{Primary})}}{3}$$

*Divide the primary voltage by the ratio*

$$V_{P(\text{secondary})} = \frac{207.85}{3}$$

*Secondary phase voltage is 69.28V*

In Delta the line voltage equals the phase voltage so:

$$V_{L(\text{secondary})} = V_{P(\text{secondary})}$$

*They are equal*

$$V_{P(\text{secondary})} = 69.28V$$

*Line voltage is 69.28V*

## Star / Star



### Primary

$$V_P = \frac{V_L}{\sqrt{3}}$$

*Phase voltage is root three smaller than line voltage*

$$V_P = \frac{360}{\sqrt{3}}$$

*360V divided by the square root of three*

$$V_P = 207.85V$$

### Secondary

$$V_{P(Secondary)} = \frac{V_{P(Primary)}}{3}$$

*Divide the primary voltage by the ratio*

$$V_{P(Secondary)} = \frac{207.85}{3} = 69.28V$$

*Secondary phase voltage is 69.28V*

In Star the line voltage will be  $\sqrt{3}$  bigger than the phase voltage, so:

$$V_{L(Secondary)} = V_{P(Secondary)} \times \sqrt{3}$$

*Line voltage is root three bigger*

$$V_{L(Secondary)} = 69.28V \times \sqrt{3}$$

*Line voltage 69.28V times root three*

$$V_{L(Secondary)} = 120V$$

We will now look at the current values in the four systems.

## Transformer Configuration Current Calculations

Let's look at an example that has a 360V input voltage (input is always the line voltage) and a turns ratio of 3:1 (turns ratio at the winding). The primary line current is 12A in each case.

### Delta/Delta

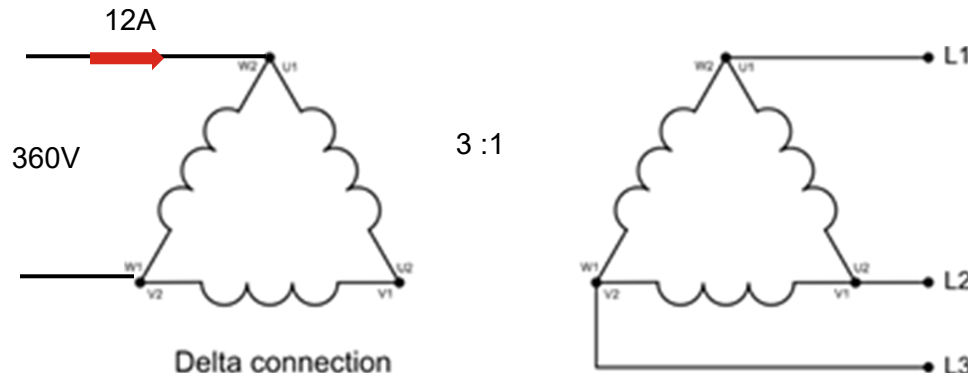

### Primary

$$I_P = \frac{I_L}{\sqrt{3}}$$

*Phase current is root 3 smaller than line current*

$$I_P = \frac{12}{\sqrt{3}} = 6.93A$$

*6.93A will flow in the winding*

### Secondary

The ratio of the current will go up by 3 because the ratio of the voltage went down by 3.

$$I_{P(\text{secondary})} = I_{P(\text{Primary})} \times 3$$

*Multiply the primary current by 3*

$$I_{P(\text{secondary})} = 6.93 \times 3 = 20.78A$$

*Secondary phase current is 20.78A*

In Delta the line current is root three bigger than the phase current, so:

$$I_{L(\text{secondary})} = I_{P(\text{secondary})} \times \sqrt{3}$$

*Line current is root three bigger*

$$I_{L(\text{secondary})} = 20.78A \times \sqrt{3}$$

*Line current = 20.78 times root three*

$$I_{L(\text{secondary})} = 36A$$

## Delta/Star

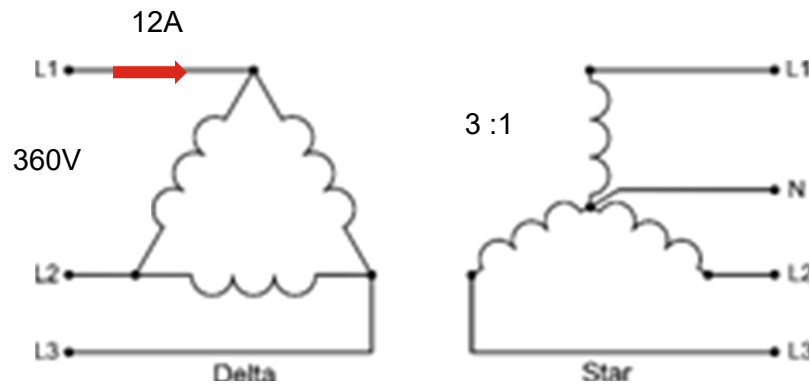

### Primary

$$I_P = \frac{I_L}{\sqrt{3}}$$

*Phase current is root 3 smaller than line current*

$$I_P = \frac{12}{\sqrt{3}} = 6.93A$$

*6.93A will flow in the winding*

### Secondary

The ratio of the current will go up by 3 because the ratio of the voltage went down by 3.

$$I_{P(\text{secondary})} = I_{P(\text{Primary})} \times 3$$

*Multiply the primary current by 3*

$$I_{P(\text{secondary})} = 6.93 \times 3 = 20.78A$$

*Secondary phase current is 20.78A*

In Star the line current is the same as the phase current, so:

$$I_{L(\text{secondary})} = I_{P(\text{secondary})}$$

*Line current equals phase current*

$$I_{L(\text{secondary})} = 20.78A$$

*Line current is 20.78A*



## Star / Delta

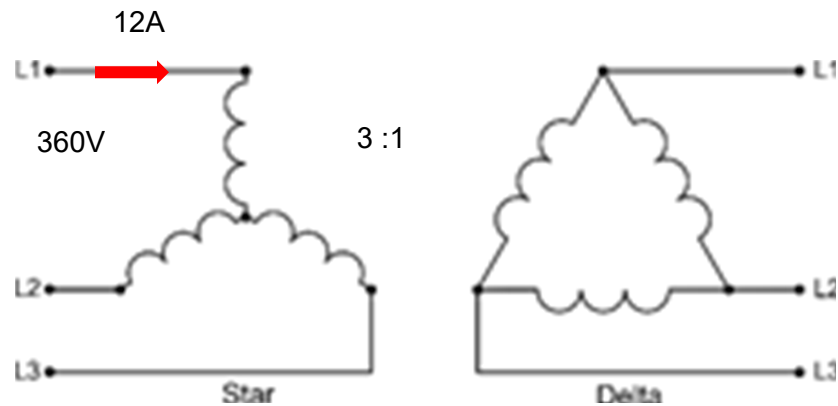

### Primary

$$I_P = I_L$$

*Phase current is same as line current*

$$I_P = 12A$$

*12A will flow in the winding*

### Secondary

The ratio of the current will go up by 3 because the ratio of the voltage went down by 3.

$$I_{P(\text{secondary})} = I_{P(\text{Primary})} \times 3$$

*Multiply the primary current by 3*

$$I_{P(\text{secondary})} = 12 \times 3 = 36A$$

*Secondary phase current is 36A*

In Delta the line current is root three bigger than the phase current, so:

$$I_{L(\text{Secondary})} = I_{P(\text{secondary})} \times \sqrt{3}$$

*Line current is root three bigger*

$$I_{L(\text{Secondary})} = 36A \times \sqrt{3}$$

*Line current = 36 times root three*

$$I_{P(\text{secondary})} = 62.35A$$

## Star / Star

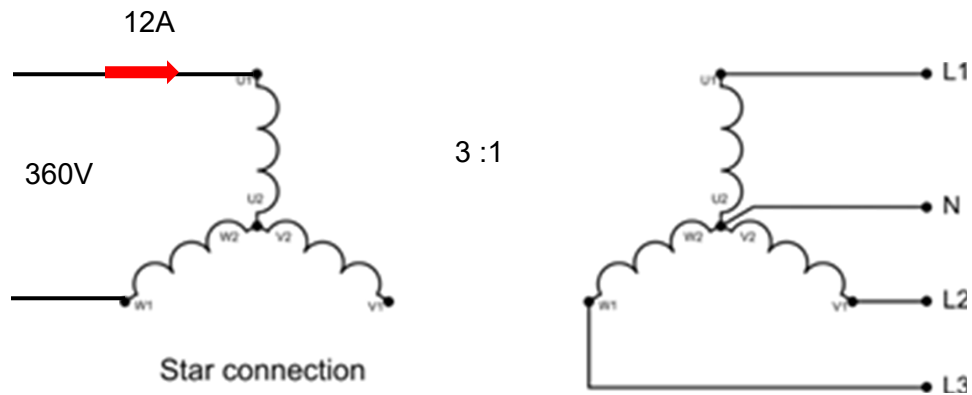

### Primary

$$I_P = I_L$$

*Phase current is same as line current*

$$I_P = 12A$$

*12A will flow in the winding*

### Secondary

The ratio of the current will go up by 3 because the ratio of the voltage went down by 3.

$$I_{P(\text{secondary})} = I_{P(\text{Primary})} \times 3$$

*Multiply the primary current by 3*

$$I_{P(\text{secondary})} = 12 \times 3 = 36A$$

*Secondary phase current is 36A*

In Star the line current is equal to the phase current

$$I_{L(\text{secondary})} = I_{P(\text{secondary})}$$

*Line current = Phase Current*

$$I_{L(\text{secondary})} = 36A$$

*Line current = 36A*

## Delta-Star Step Down Calculations

A three phase delta-star 200kVA fully loaded transformer has a turns ratio of 300 to 1.

The primary is connected to 60kV three phase supply. Let's look at the voltages and currents within this transformer



### Secondary Phase Voltage

First, we must determine the Primary Phase Voltage.

Because the primary is in Delta, the 60kV on the line (input voltage) is also seen across the windings. We know

$$V_P = V_L$$

*Phase voltage is equal to line voltage*

$$V_P = 60kV$$

*We will see 60kV across each winding of the primary*

The secondary phase voltage will now just be the primary phase voltage divided by the ratio

$$V_{P(\text{secondary})} = \frac{V_{P(\text{Primary})}}{300}$$

*Divide the primary voltage by the ratio*

$$V_{P(\text{secondary})} = \frac{60kV}{300} = 200V$$

*Secondary phase voltage is 200V*

In Star the line voltage will be  $\sqrt{3}$  bigger than the phase voltage, so:

$$V_{L(\text{secondary})} = V_{P(\text{secondary})} \times \sqrt{3} \quad \text{Line voltage is root three bigger}$$

$$V_{L(\text{secondary})} = 200V \times \sqrt{3} \quad \text{Line voltage 200V times root three}$$

$$V_{L(\text{secondary})} = 346.41V$$

In order to calculate the current in the transformer we are going to use the VA formula

$$S = \sqrt{3} V_L I_L \quad (\text{measured in VA})$$

For this transformer we know that the VA is 200000 VA (200kVA) and so we can transpose the formula to give us a formula for I (current)

$$S = \sqrt{3} V_L I_L \quad \text{If we divide both sides by } \sqrt{3} V_L \text{ we get ...}$$

$$\frac{S}{\sqrt{3} V_L} = \frac{\sqrt{3} V_L I_L}{\sqrt{3} V_L} \quad \text{The } \sqrt{3} V_L \text{ 's cancel leaving } I_L$$

The  $\sqrt{3} V_L$  on the right-hand side of the equation will cancel each other out leaving

$$\frac{S}{\sqrt{3} V_L} = I_L$$

We can turn the equation around to give us

$$I_L = \frac{S}{\sqrt{3} V_L}$$

So, the current is equal to the S (VA) divided by root three times the voltage.

For the primary current we will use the primary voltage (60kV) and for the secondary current we will use the secondary line voltage (346.41V)

### Primary line current

$$I_L = \frac{S}{\sqrt{3} V_L}$$

$$I_L = \frac{200000}{\sqrt{3} \times 60000} = 1.92A$$

### Secondary line current

$$I_L = \frac{S}{\sqrt{3} V_L}$$

$$I_L = \frac{200000}{\sqrt{3} \times 346.41} = 333.34A$$

Notice that the lower voltage in the secondary has given us a much higher secondary current than that flowing in the primary.

## Volt Drop in Windings

When the load on a transformer increases there is an increase of current ( $I$ ) flowing through the windings of the transformer. The windings have impedance ( $Z$ ) and the current flow through them causes a volt drop ( $V = I Z$ )

An increase in current due to the increase in load will therefore cause an increase in volt drop and cause a voltage decrease at the secondary terminals of the transformer. There is less voltage for the load because of the increased voltage drop in the windings.

## Correcting Volt Drop Due to Increased Load

A device called a tap changer is used to correct the falling voltage due to increased load

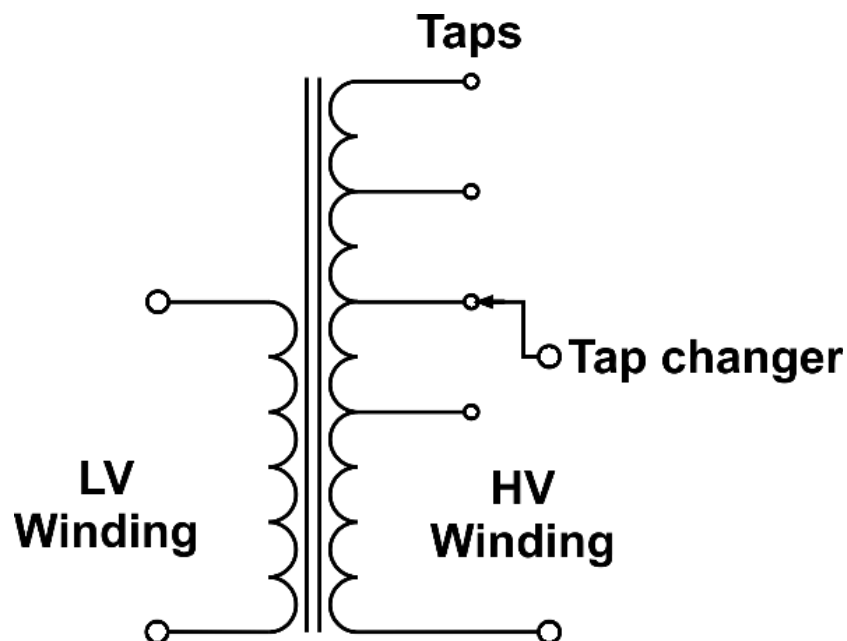

It is fitted on the high voltage side of the transformer and is used to change the point at which the voltage is 'tapped off'. The high voltage side is chosen because the current is lower, and it is safer to change because of the lower current.

In the diagram above, the higher the position of the tap changer, the higher the output voltage.

If the terminal voltage falls because of an increase in load the tap can be moved higher to introduce more windings into the circuit and increase the voltage

## Voltage Regulation

The voltage regulation percentage gives us an indication of how much voltage is 'lost' when the transformer is loaded. It compares the voltages at no-load and full-load.

### Formula

The formula for voltage regulation is

***f(x)***

$$\text{Voltage Regulation \%} = \frac{V_{NL} - V_{FL}}{V_{FL}} \times 100\%$$

An example would be a transformer that has a no-load output voltage of 235V and a full load voltage of 225V. Let's calculate the percentage regulation

$$\text{Voltage Regulation \%} = \frac{(V_{NL} - V_{FL})}{V_{FL}} \times 100\%$$

$$\text{Voltage Regulation \%} = \frac{(235 - 225)}{225} \times 100\%$$

$$\text{Voltage Regulation \%} = \frac{10}{225} \times 100\%$$

$$\text{Voltage Regulation \%} = 4.44\%$$

## Transformer Tests for Copper and Iron Losses

The copper losses ( $I^2R$  Losses) and iron losses (Hysteresis and Eddy current losses) can be determined by performing two tests. Once these values are known, then the optimum load for peak efficiency can be calculated (where copper losses equal the combined iron losses).

### Open circuit load test(iron losses)

This test is used to determine the iron losses of the transformer. The primary winding is connected to the supply (via a wattmeter) and the secondary winding is left open circuit. Note that the supply must be at the rated voltage and frequency, i.e.:

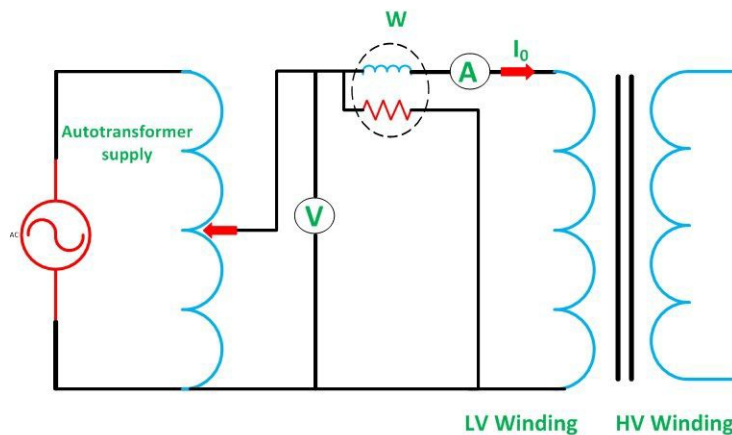

There will be no secondary current as it is open circuit. Consequently, there will be no secondary  $I^2R$  losses registered by the wattmeter in the primary of the circuit. As there is no closed secondary circuit, the only current in the primary will be that required to meet the effects of the iron losses. This primary current (on no load) is usually less than 5% of the full load current. The  $I^2R$  loss on no load is therefore less than 5% (or  $1/20$ ) squared, so it is less than  $1/400$  of the primary  $I^2R$  loss on full load. It can therefore be ignored, and the wattmeter reading taken as the iron loss of the transformer.

The reading on the wattmeter indicates the total iron losses of the device, and these losses are constant independent of the load. They are dedicated to the transformer due to its physical construction. This current flows in order to create the magnetic flux in the core. This current is often termed the magnetising current

## Short circuit load test (copper losses)

The copper losses are found by applying a **low** variable AC voltage to the primary winding of the transformer while the secondary winding is short circuited with an ammeter. The primary voltage is increased until the ammeter reads the full rated current for that winding. The watts input to the transformer is measured with a wattmeter.

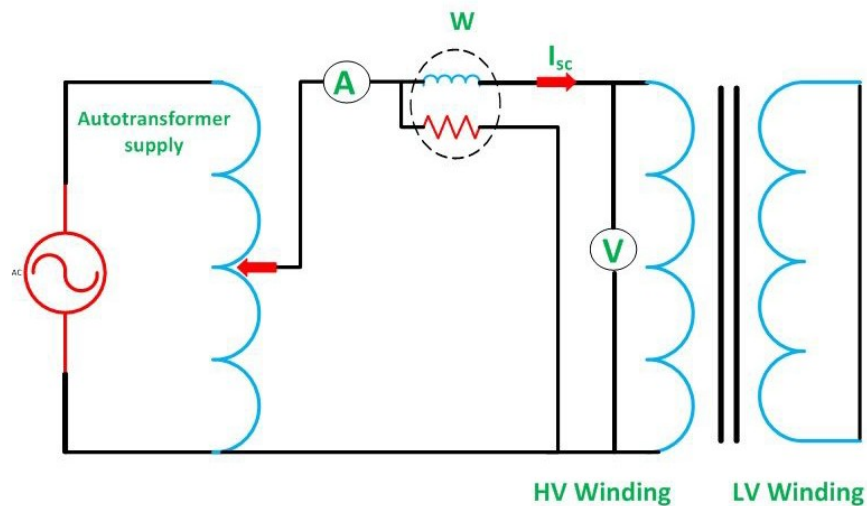

Note that the applied voltage is only about 1/20 to 1/30 of the rated voltage, and so the magnetic flux is reduced in the same order of magnitude. As iron losses are approximately equal to flux squared, it is reduced to 1/400 to 1/900 of the iron loss at the rated voltage. It can therefore be ignored, and the wattmeter reading taken to be the copper loss of the transformer.

As the copper loss varies with the square of the load, it is for this reason that there will be an optimum load for maximum efficiency.



## Example Calculation

The following results were obtained from tests on a **200kVA** single phase transformer.

800W was recorded during an open circuit test (fixed iron losses)

950W was recorder during the short circuit test (variable copper losses))

If the power factor of the load is 0.8 calculate the efficiency of the transformer under full load and at half load

### Efficiency at Full Load

We first have to calculate the power of the transformer in Watts using the power factor

$$\text{Watts} = \text{VA} \times \text{power factor}$$

$$\text{Watts} = 200000 \text{ VA} \times 0.8 = \mathbf{160000 \text{ Watts}}$$

The efficiency of the transformer is, as in any 'machine, Power Out / Power In.

$$\text{Eff} = \text{Power Out} / \text{Power In} \times 100\%$$

Power in is going to be the Power Out plus all the losses. We have to put more power in than we effectively use because of the losses (iron and copper losses).

$$\text{Power In} = \text{Power Out} + \text{iron losses} + \text{copper losses}$$

$$\text{Power In} = 160000 + 800 + 950 = \mathbf{161750 \text{ Watts}}$$

$$\text{Eff} = \frac{\text{Power Out}}{\text{Power In}} \times 100\%$$

$$\text{Eff} = \frac{160000}{161750} \times 100\% = \mathbf{98.92\%}$$

### Efficiency at Half Load

We first have to find the half load output

$$\text{Half Load} = \frac{\text{FullLoad}}{2}$$

$$\text{Half Load} = \frac{160000}{2} = \mathbf{80000 \text{ Watts}}$$

The total losses will also change at half load. Although the iron losses (800W) will remain constant the copper losses are variable by the square of the load.

So copper losses at half load =  $950W \times 0.5^2 = 237.5 \text{ Watts}$

$$Eff = \frac{PowerOut}{PowerIn} \times 100\%$$

$Power In = Power Out + iron losses + copper losses$

$Power In = 80000 + 800 + 237.5 = 81037.5 \text{ Watts}$

$$Eff = \frac{PowerOut}{PowerIn} \times 100\%$$

$$Eff = \frac{80000}{81037.5} \times 100\% = 98.72\%$$

## Purpose of Three Phase Transformers

Generally, three phase transformers are used in the electricity supply system for transmission and distribution of electricity.

There are a variety of step-up and step-down transformers to change the voltage throughout the system to give an efficient transmission system (high voltage, low current, low power loss) and a low voltage distribution system which lowers the voltage to a safer value for customers. It also allows us to use smaller (and cheaper) control gear the closer the voltage gets to the customer.

However, three phase transformers may be required in other circumstances. These could be

- Domestic properties
- Commercial properties
- Industrial sites

### Domestic Properties

Some, rare, very large domestic properties may require a three phase transformer to supply their load if it is higher than 60 to 80A. This would be too high for the local cable network's single supply of 16mm<sup>2</sup>. Rural networks will also often have transformers feeding residences.

### Commercial Properties

Similar to the domestic situation, a large shop, residential block or office complex may require one if the load is higher than 60 to 80A. Again, this would be too high for the local cable network. It would also allow the many loads of say a residential block to be balanced across the three phases of the transformer.

### Industrial

An industrial site may be supplied by a HV or LV transformer. It would be used where the load needed by the site is greater than the local cable network can supply. It would allow the industrial site to balance its loads across the three phases.

## Potential hazards associated with transformers

Electrical hazards pose a serious threat to worker safety. Many workers are unaware of the potential electrical hazards present in their work environment which makes them more vulnerable to the danger of electrocution and arc flash incidents.

Unsafe equipment, unsafe acts, and working alone and with live electrical circuits can lead to electrical accidents and injuries

Hazards can include, but not limited to:

- Explosion
- Fire
- Electric shock electrocution
- Damage to equipment and property
- Lost time and production

## Precautions to be observed when working with transformers

- Carry out a full risk assessment and job analysis
- Are you competent to carry out the necessary work?
- Familiarise yourself with the equipment
- Follow the manufacturer instructions for installation or maintenance
- Understand what you have to do
- Use the appropriate PPE
- Follow a documented switching / isolation program
- Follow test procedures
- Adhere to minimum approach distances
- Have the proper tools for the job
- Check for any burning smells
- Check for any unusual noise, rumbling, banging
- Carry out work on de-energised equipment only
- Always ground the transformer, before working on it
- Do not overload the transformer
- Do not modify the transformers protection devices
- Be aware of auxiliary power circuits
- Do not drop any tools or bolts, nuts into the transformer





The Skills Organisation

0508 SKILLS (0508 754 557)

[skills.org.nz](http://skills.org.nz)