



Candidate Code No.	
For Board Use Only	
Result	Result
Date	Date
Int	Int

ELECTRICIAN'S THEORY EXAMINATION

21 June 2014

QUESTION AND ANSWER BOOKLET

Time Allowed: Three hours

INSTRUCTIONS – READ CAREFULLY

You have 10 minutes to read this paper but do not start writing until you are told to do so by the supervisor.

Write your Candidate Code Number in the box provided above. Your name must NOT appear anywhere on this paper.

Answer all questions.

The pass mark for this examination is 60 marks.

Use a pen for written answers. **Do not** use a pencil or a red pen.

Drawing instruments and pencils may be used when diagrams are required. Marks are allocated on the basis of correctness.

Do not use correcting fluid or correcting tape.

For calculation questions all workings, including formulae, must be shown to gain full marks.

Warning – You could get 0 marks for any question, or part of a question, if you show anything hazardous or dangerous in your answer.

Candidates are not permitted to use any Act, Regulation, Standard, Code of Practice, Handbook or other reference text in this examination.

PLEASE HAND THIS PAPER TO THE SUPERVISOR BEFORE LEAVING THE ROOM.

(turn over)

Question 1

- (a) State the main reason why a large industrial electrical installation has a higher prospective short circuit current (PSSC) than a domestic electrical installation.

(2 marks)

- (b) A CT metering circuit is measuring the consumption of an industrial electrical installation at near to full load. The CT secondary must be short-circuited before disconnecting the meters from the CT.

State **TWO** reasons why the CT secondary must be short-circuited

(2 marks)

(1) _____

(2) _____

(turn over)

Question 1 continued

- (c) A result of fault loop impedance test at the **main switchboard** of a low voltage electrical installation will show the prospective short circuit current level of the installation or the impedance of the fault loop at the switchboard under fault conditions.

State the **main** purpose of the information gained from the earth fault loop impedance test.

(2 marks)

- (d) Some protective devices in an electrical installation have a fault duty lower than the prospective short circuit rating of the installation. State the main hazard that could occur when a high prospective short-circuit fault current occurs in the electrical installation.

(2 marks)

- (e) 100 metres of three-phase mains cable gave an insulation test result of $75\text{M}\Omega$. Calculate the insulation resistance of 375m of the same type of cable.

(2 marks)

(turn over)

Question 1 continued

(f) AS/NZS 3000 requires that a test voltage of 500V d.c. is used for an insulation resistance test of a low voltage electrical installation.

(i) Explain why a voltage of 500V is applied.

(1 mark)

(ii) Explain why the voltage is a d.c. voltage.

(1 mark)

(g) (i) Define the term **current rating** as it applies to an HRC fuse?

(1 mark)

(ii) Define the term **breaking (or rupturing) capacity** as it applies to an HRC fuse

(1 mark)

(turn over)

Question 1 continued

- (h) State **TWO** technical advantages that a soft starter has when compared to and electromechanical type starter, such as auto-transformer.

(2 marks)

(1) _____

(2) _____

- (i) (i) Explain the purpose of an interlocks in a star/delta starter

(1 mark)

- (ii) State the effect of the interlocks failing in a star/delta starter.

(1 mark)

(turn over)

Question 1 continued

- (j) (i) Define the term **pullout torque** as it applies to an a.c. induction motor.

(1 mark)

- (ii) State the synchronous speed of a three-phase, four-pole, 50 Hz motor.

(1 mark)

(turn over)

Question 2

Introduction

An electrician has installed a low voltage, three-phase, **five-pin**, socket outlet and final subcircuit wiring in a bakery. The subcircuit wiring will be **connected** at the switchboard by another electrician **at a later date**.

Use the information in the introduction to this question to answer parts 2(a) and 2(b).

- (a) State the Standard and section of that Standard that specifies the tests and checks that need to be carried out on the socket outlet and final subcircuit wiring.

(1 mark)

- (b) State the document that must be completed once all the testing and checking has been completed.

(½ mark)

- (c) State the **THREE** tests, using test instruments that the electrician needs to carry out on the final subcircuit cable and socket outlet to ensure they are safe to connect to the electrically supply.

For each test:

- State the test instrument used.
- State the test voltage, is applicable
- Describe how you would carry it out.
- State the permitted test result (if applicable).

(8½ marks)

Test 1

(turn over)

Question 2 continued

Test 2

Test 3

(turn over)

Question 3

The two figures on the following page represent a three-phase MEN switchboard and a three-phase distribution switchboard in a three-phase electrical installation

The main supply comes into the MEN switchboard and the three-phase distribution switchboard is supplied from the MEN switchboard. The distribution switchboard is protected by an RCBO.

On the figures, draw and label the circuit diagram that incorporates:

- The supply to the MEN switchboard.
- Draw the wiring for the MEN switchboard that includes:
 - * The main switch
 - * The RCBO
 - * The earth and neutral bars
 - * The necessary neutral and earthing arrangement that ensures the installation is safe.
- Draw the wiring arrangement between the MEN switchboard and the distribution switchboard.
- Draw the wiring for the distribution switchboard that includes:
 - * The main switch
 - * The earth and neutral bars
 - * The necessary neutral and earthing arrangement that ensures the installation is safe.

The metering and other final subcircuits, MCBs, RCDs on both switchboards **do not** need to be drawn.

(10 marks)

(turn over)

Question 3 continued



MEN Switchboard



Distribution Switchboard

(turn over)

Question 4

Introduction

The inverse time characteristic curve graph below shows typical characteristic curves for various fuse sizes.

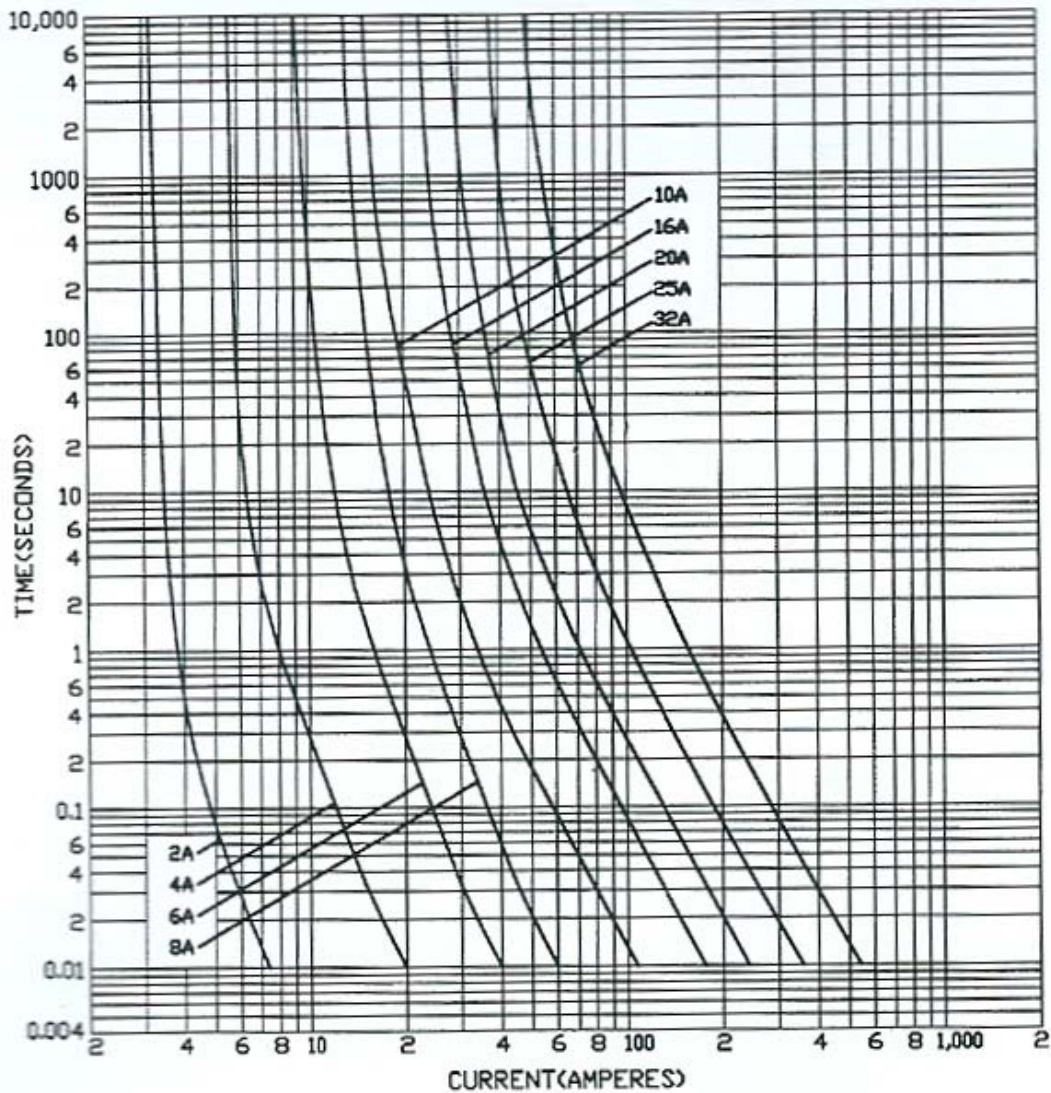

Use the information in the graph to answer parts 4(a), 4(b), 4(c) and 4(d)

(turn over)

Question 4 continued

- (a) Which one of these fuses with a pre-arcing time of 0.1 seconds would blow when a fault of 60A flows?

(1 mark)

- (b) The graph in the introduction is an inverse time characteristic curve graph

- (i) Define the term **inverse time characteristic**.

(1 mark)

- (ii) Show how the inverse time characteristic applies to a 20A HRC fuse. Use fault currents of 40A and 100A.

(2 marks)

(turn over)

Question 4 continued

(c) Some of the HRC fuses protect final subcircuits.

For each of the following fuses:

- Calculate the **minimum fusing current** (assume a utilisation category (fusing factor) of 1.5).
- Refer to the graph and state the **minimum fault current** that needs to flow so that the fuse operates within the 0.4s required by AS/NZS 3000.

(6 marks)

6A

Minimum fusing current _____

Minimum fault current _____

8A

Minimum fusing current _____

Minimum fault current _____

16A

Minimum fusing current _____

Minimum fault current _____

20A

Minimum fusing current _____

Minimum fault current _____

25A

Minimum fusing current _____

Minimum fault current _____

32A

Minimum fusing current _____

Minimum fault current _____

(turn over)

Question 5

(a) The diagram below is a control circuit for a star delta starter. The remote start/stop station and remote emergency stop are to be added to the circuit. Draw the conductors that connect the remote start/stop station and remote emergency stop to the existing circuit.

- You can use only use **FIVE** conductors to connect the remote start/stop station and remote emergency stop:
- You must remove **ONE** conductor from the existing circuit - show this by crossing the conductor out like this ~~—~~

(4 marks)

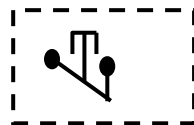

Remote emergency stop

Remote start/stop

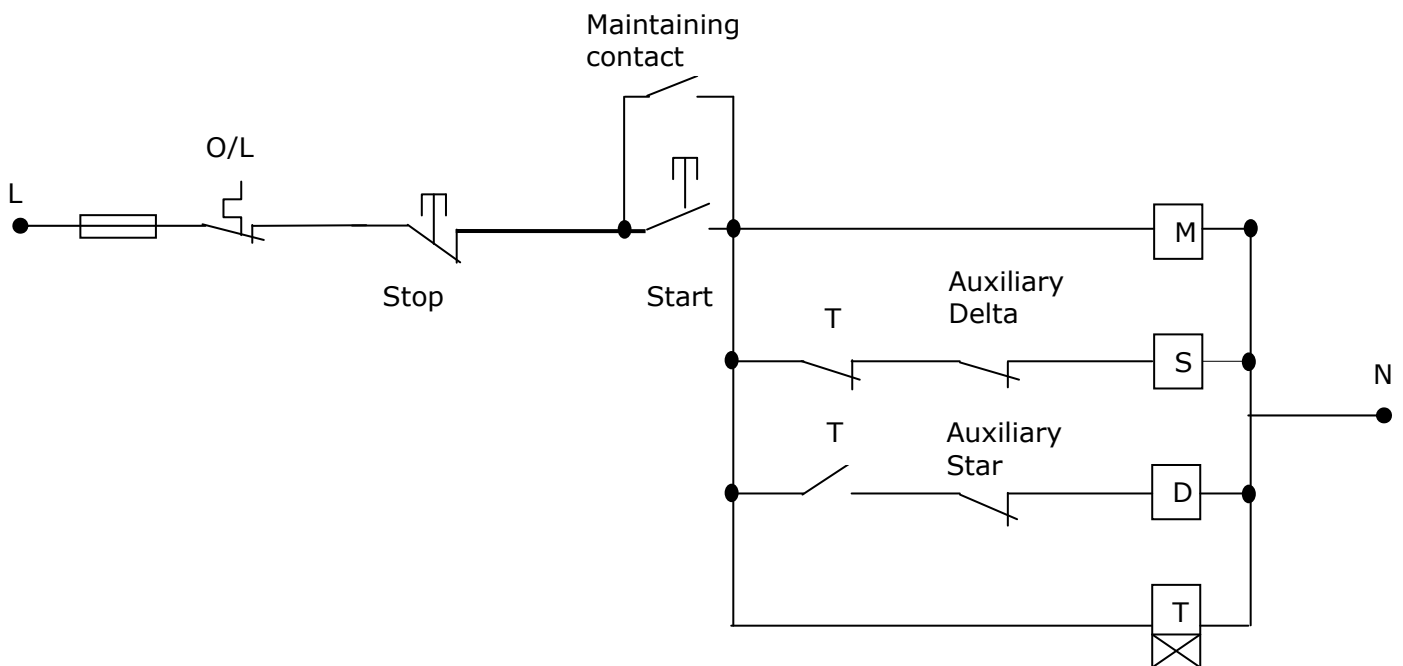
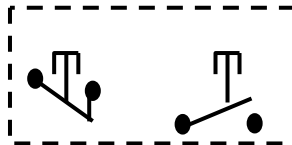

(turn over)

Question 5 continued

- (b) You have been requested to wire the **power circuit** for a single-phase 550W, capacitor-start induction motor for a garage roller door. The motor is required to operate in forward and reverse directions.

The figure below shows the components of the capacitor-start motor and the forward and reverse contactors. Draw in the conductors for the **power circuit** that enables the motor to operate in the forward and reverse directions.

The fuse or the isolator **do not** need to be shown.

(6 marks)

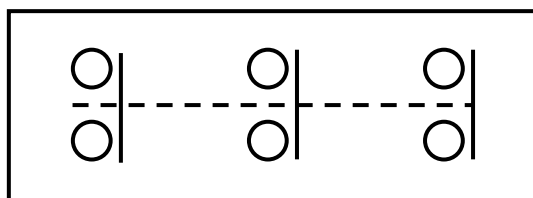
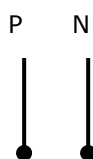

Forward

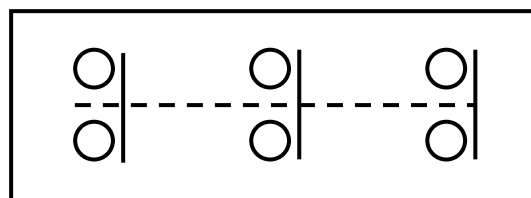

Reverse



Run winding

Capacitor



Start winding

Centrifugal switch

(turn over)

Question 6

- (a) New mains have been installed in a 230V, single-phase domestic installation. During the work the phase and neutral were interchanged at the mains entry box.

State **TWO** potentially hazardous situations that could arise when the installation was livened.

(2 marks)

(1) _____

(2) _____

- (b) New mains have been installed in a 230V, single-phase domestic installation. **The installation has been livened.**

The main switch and MEN system are contained within a **metal meter box.**

- (i) State the equipment you would use to determine whether or not a phase/neutral transposition has occurred on the mains.

(1½ marks)

(turn over)

Question 7

Introduction

The figure below represents a three-phase, star-connected 400V, 18 kW commercial oven. The oven is protected by 40A HRC fuses with a fusing factor (gG Utilisation Category) of 1.5.

An earth fault of 6Ω has developed between L1 and the oven frame while the oven is operating. The fault occurred at point X.

The protective earthing conductor resistance is 9.75Ω due to a high resistance termination.

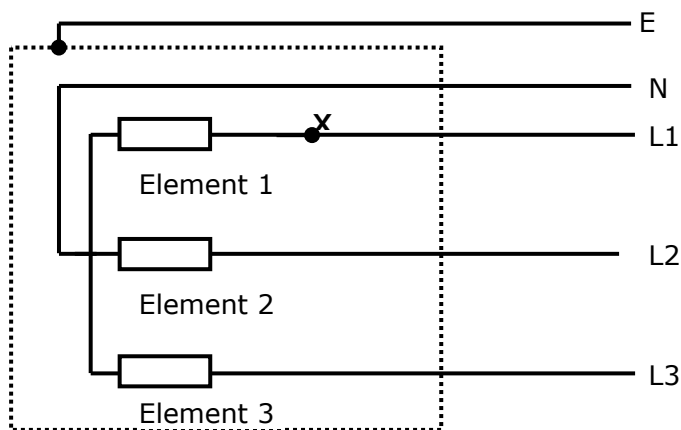

Use the information in the introduction to this question to answer Parts 7(a) and 7(b).

- (a) (i) Calculate the total current that will flow in L1 under the fault conditions.
- (5 marks)

(turn over)

Question 7 continued

(ii) Explain by calculations:

(1) Whether the fuse protecting L1 will operate.

(1 mark)

(2) Whether any hazard exists to the operator of the oven.

(2 marks)

(b) If the fault at point X was of negligible impedance, calculate the maximum resistance in the protective earthing conductor that would ensure the fault current exceeded the fusing current of the fuse by a margin of 1A.

(2 marks)

(turn over)

Question 8

Introduction

The figure below is a delta-connected heater supplied from a 400V, three-phase supply.

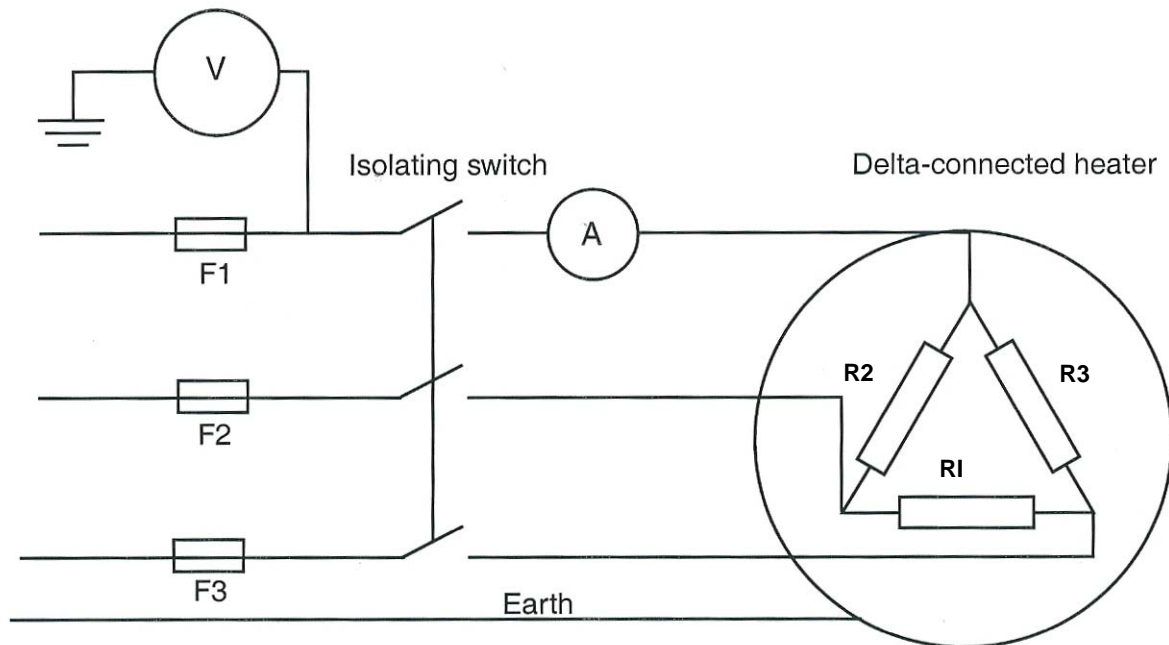

Each element has a resistance of $20\ \Omega$

Use the information in the introduction to this question to answer parts 6(a), 6(b) and 6(c).

(a) Use the information in the introduction to calculate the reading on the ammeter when the heater is fully operational.

(4 marks)

turn over)

Question 8 continued

- (b) Use the information in the introduction to calculate the reading on the ammeter **if Element R2 became open-circuited while the heater was operating.**

(2 marks)

- (c) Use the information in the introduction to calculate the reading on the ammeter **if Fuse F3 was removed and the heater was switched on.**

(4 marks)

(turn over)

Question 9

(a) The circuit supplying a 230V, single-phase wash-down pump has both RCCB and MCB protection. The pump isolating switch has been replaced.

(i) If the phase and neutral were accidentally interchanged at the **supply side** of the isolating switch, what would be the effect when the pump was turned on?

(3 marks)

(ii) If the neutral and earth were accidentally interchanged at the **supply side** of the isolating switch, what would be the effect when the pump was turned on?

(1 mark)

(b) State **ONE** test that would detect the interchange of the phase and neutral conductors **before** the electricity supply is livened.

(1 mark)

(turn over)

Question 9 continued

- (c) A three-phase, 400V, four-wire distribution board has a load of 7.4kW on the red phase, 2.8kW on the white phase and 7.4kW on the blue phase.

Determine the neutral current using a graphical method.

(5 marks)

For Candidate's Use

In the box, write the number of **EXTRA** sheets you have used. Write **NIL** if you have not used any

For Examiner's Use Only		
Questions Answered	Marks	
1		
2		
3		
4		
5		
6		
7		
8		
9		
TOTAL		